

**NOTICE OF INTENT  
TO ADOPT A MITIGATED NEGATIVE DECLARATION**

**LEAD AGENCY**                    Sutter County Development Services Department  
   Planning Division  
   1130 Civic Center Boulevard, Suite A  
   Yuba City, CA 95993

**PROJECT TITLE:**                Project No. U22-0011 (Dhudwal)

**CONTACT PERSON:**            Casey Murray, Senior Planner (530) 822-7400, ext. 245;  
[cmurray@co.sutter.ca.us](mailto:cmurray@co.sutter.ca.us)

**PROJECT LOCATION:**        8645 Garden Highway, Yuba City, CA 95991, on the west side of the intersection of Ashford Avenue and Garden Highway, approximately 900 feet south of Tudor Road; Assessor's Parcel No.: 25-090-029.

**PROJECT DESCRIPTION:** A use permit for a large general truck yard for a maximum of 189 trucks and trailers.

**FINDINGS/DETERMINATION:** An Initial Study of the effect of this project has been made, and it has been determined that there will be no significant adverse effects on the quality of the environment with mitigation incorporated; therefore, a Mitigated Negative Declaration is proposed.

**PUBLIC REVIEW PERIOD:** A 30-day public review period for the Mitigated Negative Declaration will commence on January 11, 2023 and end at 5pm on February 9, 2023, for interested and concerned individuals and public agencies to submit written comments on the document. Any written comments on the Mitigated Negative Declaration must be received within the public review period. Copies or an electronic version of the Mitigated Negative Declaration are available for review or purchase at the County address provided above and available online at:  
<https://www.suttercounty.org/government/county-departments/development-services/planning-services/project-notices-and-environmental-documents>

**PUBLIC MEETING:** This project has not been scheduled for a public hearing at this time.

**COUNTY OF SUTTER**  
**MITIGATED NEGATIVE DECLARATION**

**PROJECT TITLE:** Project #U22-0011 (Dhudwal)

**PROJECT SPONSORS:** Applicant and Owner:  
Sarbjit Dhudwal  
697 N. Palora Avenue, Suite C, Yuba City, CA 95991

Project Engineer:  
Jeff Spence  
Laughlin and Spence  
1008 Live Oak Boulevard, Yuba City, CA 95991

**PROJECT LOCATION:** 8645 Garden Highway south of Yuba City, on the west side of Garden Highway, west of the intersection of Ashford Avenue and Garden Highway, approximately 900 feet south of Tudor Road

**ASSESSOR'S PARCEL NO:** 25-090-029

**PROJECT DESCRIPTION:** A use permit for a large general truck yard for a maximum of 189 trucks and trailers.

---

An Initial Study has been conducted by the Environmental Control Officer of the County of Sutter. The Environmental Control Officer finds that this project will not have a significant effect on the environment. The Initial Study is available for public review at the Sutter County Development Services Department, 1130 Civic Center Boulevard, Suite A, Yuba City, California. (Phone: 530-822-7400)

STATEMENT OF REASONS TO SUPPORT FINDING  
OF MITIGATED NEGATIVE DECLARATION

Staff has conducted an Initial Study for this project, which revealed that the proposed project could have significant impact on the environment; however, the recommended mitigation measures would reduce the possible impacts to a less than significant level.

  
\_\_\_\_\_  
Neal Hay  
Director of Development Services  
Environmental Control Officer

  
\_\_\_\_\_  
Date

*ADMINISTRATIVE REVIEW DRAFT*  
INITIAL STUDY/  
MITIGATED NEGATIVE DECLARATION

FOR THE

SARBJIT DHUDWAL TRUCK PARKING YARD  
8645 GARDEN HIGHWAY  
SUTTER COUNTY, CA

SUTTER COUNTY PROJECT #U22-0011

JANUARY 2023

*Prepared for:*  
SUTTER COUNTY DEVELOPMENT SERVICES DEPARTMENT  
1130 CIVIC CENTER BOULEVARD  
YUBA CITY, CA 95993

*Prepared by:*  
BASECAMP ENVIRONMENTAL, INC.  
802 W. LODI AVENUE  
LODI, CA 95240



BaseCamp Environmental, Inc.

*ADMINISTRATIVE REVIEW DRAFT*  
INITIAL STUDY/  
MITIGATED NEGATIVE DECLARATION

FOR THE

SARBJIT DHUDWAL TRUCK PARKING YARD  
8645 GARDEN HIGHWAY  
SUTTER COUNTY, CA

SUTTER COUNTY PROJECT #U22-0011

JANUARY 2023

*Prepared for:*

Sutter County Development Services Department  
1130 Civic Center Boulevard  
Yuba City, CA 95993

*Prepared by:*

BaseCamp Environmental, Inc.  
802 W. Lodi Avenue  
Lodi, CA 95240

# Table of Contents

	Page
Chapter 1.0 SUTTER COUNTY INITIAL STUDY	
A. General Project Information	1
B. Environmental Factors Potentially Affected	4
C. Determination	5
Chapter 2.0 CHECKLIST	
I Aesthetics	12
II Agriculture and Forestry Resources	14
III Air Quality	16
IV Biological Resources	21
V Cultural Resources	23
VI Energy	24
VII Geology and Soils	25
VIII Greenhouse Gas Emissions	29
IX Hazards and Hazardous Materials	30
X Hydrology and Water Quality	33
XI Land Use and Planning	36
XII Mineral Resources	37
XIII Noise	38
XIV Population and Housing	40
XV Public Services	41
XVI Recreation	42
XVII Transportation	43
XVIII Tribal Cultural Resources	47
XIX Utilities and Service Systems	49

XX	Wildfire	50
XXI	Mandatory Findings of Significance	51
	Bibliography	54
Chapter 3.0 MITIGATION MONITORING PROGRAM		56

## APPENDICES

- A. Project Drawings
- B. Air Quality and Greenhouse Gas Analysis
- C. Environmental Noise Assessment
- D. Transportation Impact Analysis

## LIST OF TABLES

1	FRAQMD Significance Thresholds and Project Emissions	17
---	--	----

## LIST OF FIGURES

1-1	Regional Location Map	6
1-2	Street Map	7
1-3	USGS Map	8
1-4	Aerial Photo	9
1-5	Assessor's Parcel Map	10
1-6	Site Plan	11

---

LIST OF ACRONYMS AND ABBREVIATIONS USED IN THIS DOCUMENT

---

AB	Assembly Bill
BMP	Best Management Practice
CalEEMod	California Emissions Estimator Model
CAP	Climate Action Plan
CARB	California Air Resources Board
Caltrans	California Department of Transportation
CCR	California Code of Regulations
CDFW	California Department of Fish and Wildlife
CEQA	California Environmental Quality Act
CO	carbon monoxide
CO <sub>2</sub> e	carbon dioxide equivalent
CUPA	Certified Unified Program Agency
dBA	decibel, A-weighted
DPM	diesel particulate matter
EIR	Environmental Impact Report
FEMA	Federal Emergency Management Agency
FRAQMD	Feather River Air Quality Management District
GHG	greenhouse gas
LOS	Level of Service
NAHC	Native American Heritage Commission
NO <sub>x</sub>	nitrogen oxides
NPDES	National Pollutant Discharge Elimination System
OPR	Governor's Office of Planning and Research
PG&E	Pacific Gas and Electric Company
PM <sub>10</sub>	particulate matter 10 microns or less in diameter
PM <sub>2.5</sub>	particulate matter 2.5 microns or less in diameter
PPV	peak particle velocity
ROG	reactive organic gases
RWQCB	Regional Water Quality Control Board
SB	Senate Bill
STAA	Surface Transportation Assistance Act
SWPPP	Storm Water Pollution Prevention Plan
TA	Terminal Access
TAC	toxic air contaminant
TCR	tribal cultural resource

THRIS	Tribal Historic Information System
TRU	Transport Refrigeration Unit
UAIC	United Auburn Indian Community
USDA	United States Department of Agriculture
USFWS	U.S. Fish and Wildlife Service
VMT	vehicle miles traveled

# Sutter County Initial Study

- 1. Project Title:** Project #U22-0011 (Dhudwal)
- 2. Lead Agency Name and Address:** Sutter County Development Services Dept.  
Planning Division  
1130 Civic Center Boulevard  
Yuba City, CA 95993
- 3. Contact Person and Phone Number:** Casey Murray, Senior Planner  
530-822-7400 ext. 245
- 4. Project Sponsor's Name and Address:**
- Project Applicant and Owner  
Sarbjit Dhudwal  
697 N. Palora Avenue, Suite C  
Yuba City, CA 95991
- Project Engineer  
Jeff Spence  
Laughlin and Spence  
1008 Live Oak Boulevard  
Yuba City, CA 95991
- 5. Project Location & APN:** 8645 Garden Highway south of Yuba City, on the west side of Garden Highway, west of the intersection of Ashford Avenue and Garden Highway, approximately 900 feet south of Tudor Road; APN: 25-090-029
- 6. General Plan Designation:** AG-80 (Agriculture, 80-acre minimum)
- 7. Zoning Classification:** AG (Agriculture) District

**8. Description of Project:**

The project site (Figures 1-1 to 1-5) consists of a 14.08-acre parcel, of which 12 acres is currently planted in a walnut orchard. The walnut orchard is proposed to be removed, except approximately 17 walnut trees will remain in the southeast corner of the site. An existing single-family residence and accessory buildings are located on the site adjacent to Garden Highway and are proposed to remain. The single-family residence has experienced apparent fire damage and is currently unoccupied; however, it is proposed to be repaired. An existing groundwater well is on the project site south of the existing residence.

The project applicant seeks to obtain a use permit for a truck parking yard (Figure 1-6). The truck yard would provide parking for 189 trucks and trailers and 62 light vehicles. The

proposed truck and light vehicle parking areas comprise approximately nine acres. The site plan indicates that some of the light vehicle parking will be accommodated in the proposed truck parking spaces. The truck parking and circulation aisles will be chip sealed, while the light vehicle parking spaces will be paved with asphalt. No new building construction is proposed, and no repairs of trucks, trailers, or light vehicles would be conducted on site. As noted on the site plan depicted in Figure 1-6, all truck engines on the site are proposed to be model year 2014 or newer, and no trailers equipped with transport refrigeration units (TRUs) will be stored or will be in operation at the site.

Project area operations will involve trucks accessing the site intermittently, 24 hours per day, 7 days per week. Weekdays, most trucks will depart the site between 6:00 a.m. and 8:00 a.m. and return at various hours. Most trucks that leave will return approximately three to four days later. If any parking spaces are used for agricultural trucks, they likely will leave and return daily during the April through October months. The applicant estimates that individual trucks will be parked on the property two days between trips, except for agricultural trucks during the off-season. The project applicant has indicated that all trucks that would use the proposed facility would be "long haul" trucks, rather than local trucks making local trips.

Restroom facilities for drivers will consist of four portable trailers, each with two toilets and one handwashing station. The restrooms will be accessible 24 hours per day, 7 days per week. The toilets would be self-contained and would be pumped as needed by a septic pumper registered with Sutter County. Thirty-eight trash receptacles, each with a capacity of 55 gallons, will be installed throughout the truck yard.

Access to the project site would be provided off Garden Highway by a proposed 47-foot-wide ungated driveway. Proposed pavement will extend to the Garden Highway edge of road pursuant to an encroachment permit from Sutter County. A six-foot-high chain link fence with privacy slats having a 90 percent screening ability will be provided along Garden Highway as well as a portion of the north property line as denoted on the site plan. The remainder of the site will have a six-foot-high chain link fence along the property line without slats adjacent to the proposed truck parking area. The truck yard would be attended by one security staff member.

The project proposes that Surface Transportation Assistance Act (STAA) trucks be parked at the project site. STAA trucks are typically truck-tractors with sleeper units and a trailer that when combined exceed the 65-foot "California Legal" threshold. Large general truck yards may only be established in the AG District with approval of a use permit and when located immediately adjacent to a State Highway or designated STAA T or S-route. An existing STAA route has been established along Tudor Road from Highway 99 to Garden Highway. An extension of this STAA route along Garden Highway from Tudor Road south to beyond Peck Road has been approved by the California Department of Transportation (Caltrans).

A proposed grading and drainage plan, landscaping plan, photometric plan, and truck turning radii diagram are shown in Appendix A. A retention basin approximately 1.85 acres in area and 3.5 feet deep will be constructed along the western boundary of the truck parking area to mitigate the increased storm runoff. The basin will be sloped at a ratio of 4:1. Two outlets connected to storm drainage pipelines to be installed beneath the parking area will be installed in the basin, and riprap will be placed around the outlets.

Landscaping would include trees and shrubs planted along the frontage of the property and at the proposed light vehicle parking spaces. Landscaping consisting of trees also would be installed along the northern and southern boundaries of the project site. Shrubs are proposed along the west side of the truck parking area. All landscaping would be within planters separated from parking spaces and driveways with a continuous concrete curb six inches high and six inches wide. No planter would be smaller than 25 square feet, and each planter will include an irrigation system, with water to be provided by the onsite well. Areas along Garden Highway between the property frontage fence and front property line not landscaped would be treated for weed control.

Lights with LED fixtures on poles will be provided. Poles would be 25 feet in height in the truck parking area and range from 12 to 18 feet in the light vehicle parking areas. Luminaires will be directed to prevent light spillage onto adjacent properties and road right-of-way. Lighting will be operated by motion-activated sensors.

#### **9. Surrounding Land Uses and Setting:**

The project site is essentially surrounded by orchards. Garden Highway separates the project site from orchards to the east. Single-family residences are south and east of the project site; however, they are not adjacent to it.

#### **10. Other Public Agencies Whose Approval is Required: None**

#### **11. Have California Native American tribes traditionally and culturally affiliated with the project area requested consultation pursuant to Public Resources Code Section 21080.3.1? If so, is there a plan for consultation that includes, for example, the determination of significance of impacts to tribal cultural resources, procedures regarding confidentiality, etc.?**

The County initiated consultation through distribution of letters to the Native American tribes provided by the Native American Heritage Commission (NAHC). The Mooretown Rancheria and the Enterprise Rancheria both stated that they had no record of any cultural resources in the area, though they reserved the right to be notified of any post-review/inadvertent discoveries. Consultation with the United Auburn Indian Community (UAIC) resulted in the addition of a mitigation measure to address potential impacts to Tribal Cultural Resources. No requests for consultation were received from any other Native American tribes during the review period.

**ENVIRONMENTAL FACTORS POTENTIALLY AFFECTED**

The environmental factors checked below would be potentially affected by this project, involving at least one impact that is a “Potentially Significant Impact” as indicated by the checklist on the following pages.

Aesthetics	Agriculture/Forestry Resources	Air Quality
Biological Resources	Cultural Resources	Energy
Geology/Soils	Greenhouse Gas Emissions	Hazards/Hazardous Materials
Hydrology/Water Quality	Land Use/Planning	Mineral Resources
Noise	Population/Housing	Public Services
Recreation	Transportation	Tribal Cultural Resources
Utilities/Service Systems	Wildfire	Mandatory Findings of Significance

**DETERMINATION**

On the basis of this initial evaluation:

I find that the proposed project COULD NOT have a significant effect on the environment, and a NEGATIVE DECLARATION will be prepared.

✓ I find that although the proposed project could have a significant effect on the environment, there will not be a significant effect in this case because revisions in the project have been made by or agreed to by the project proponent. A MITIGATED NEGATIVE DECLARATION will be prepared.

I find that the proposed project MAY have a significant effect on the environment, and an ENVIRONMENTAL IMPACT REPORT is required.



I find that the proposed project MAY have a "potentially significant impact" or "potentially significant unless mitigated" impact on the environment, but at least one effect 1) has been adequately analyzed in an earlier document pursuant to applicable legal standards, and 2) has been addressed by mitigation measures based on the earlier analysis as described on attached sheets. An ENVIRONMENTAL IMPACT REPORT is required, but it must analyze only the effects that remain to be addressed.

I find that although the proposed project could have a significant effect on the environment, because all potentially significant effects (a) have been analyzed adequately in an earlier EIR or NEGATIVE DECLARATION pursuant to applicable standards, and (b) have been avoided or mitigated pursuant to that earlier EIR or NEGATIVE DECLARATION, including revisions or mitigation measures that are imposed upon the proposed project, nothing further is required.

**Applicant Mitigation Agreement:**

CEQA allows a project proponent to make revisions to a project, and/or to agree and comply with, mitigation measures that reduce the project impacts such that the project will not have a significant effect on the environment. CEQA Guidelines Section 15064.

As the applicant/representative for this proposed project, I hereby agree to implement the proposed mitigation measures and mitigation monitoring program identified within this document.

	01-03-2023
Signature of Applicant/Representative	Date
	1/04/2023
Neal Hay, Director of Development Services Environmental Control Officer	Date

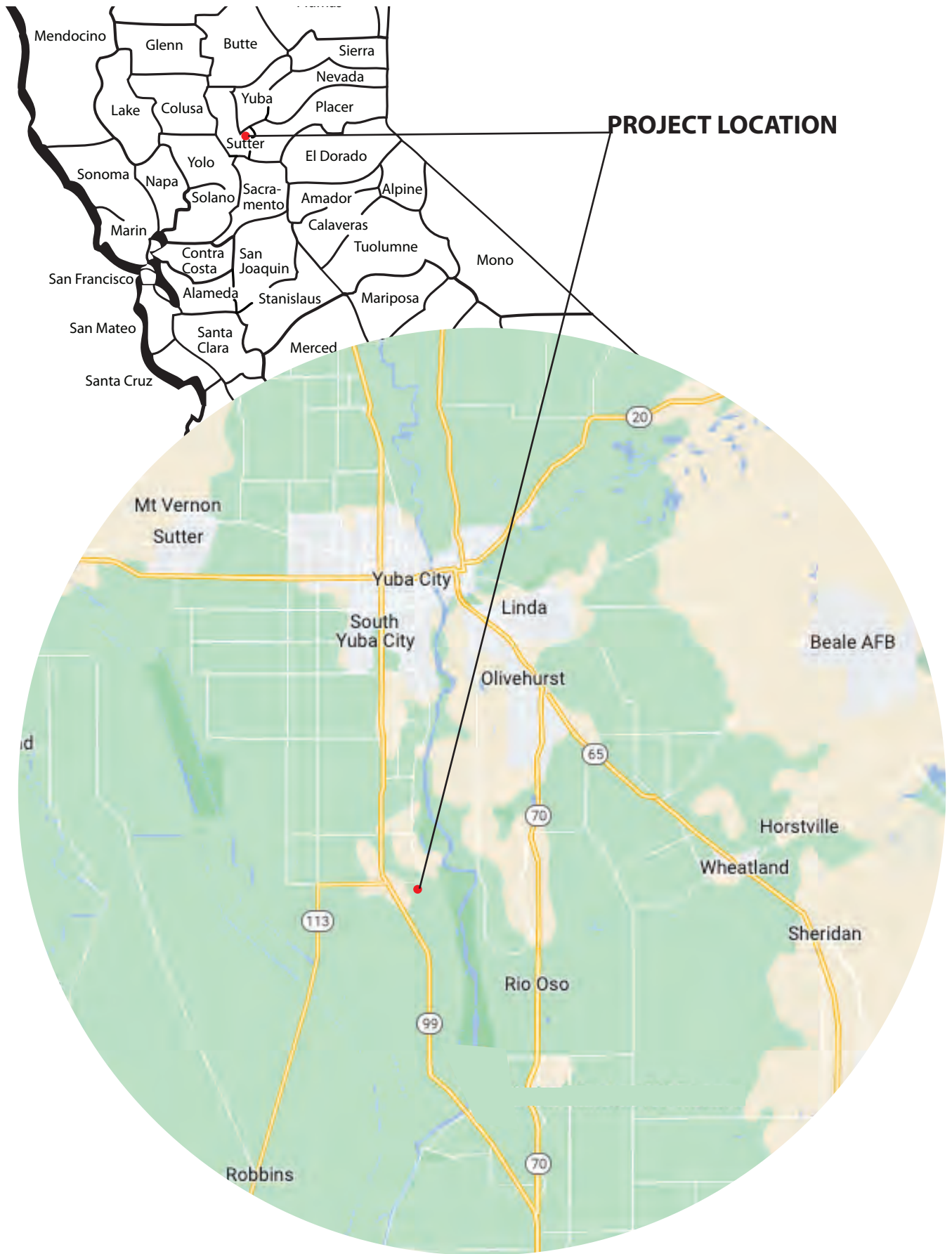

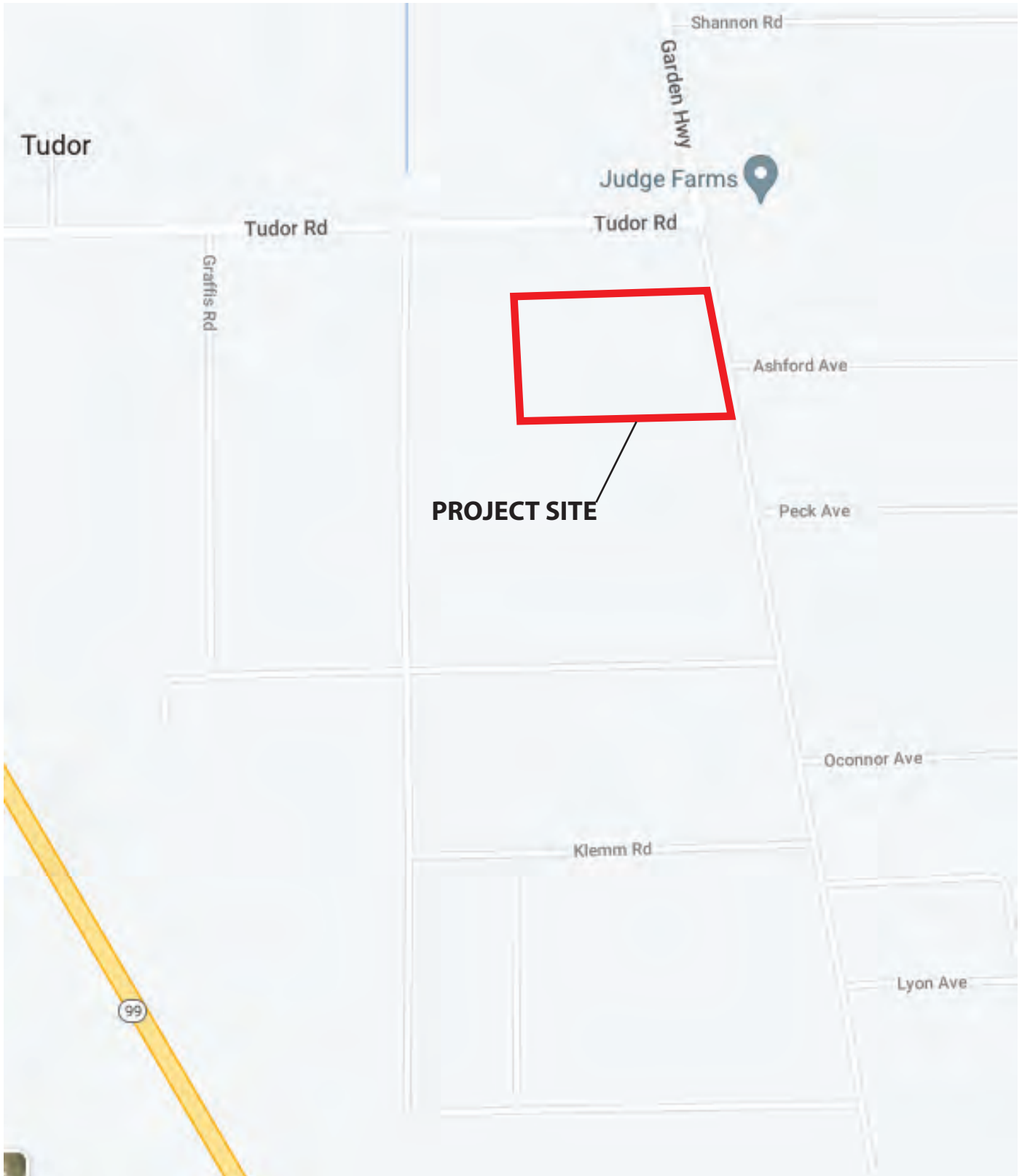

**SOURCE:** Google Maps

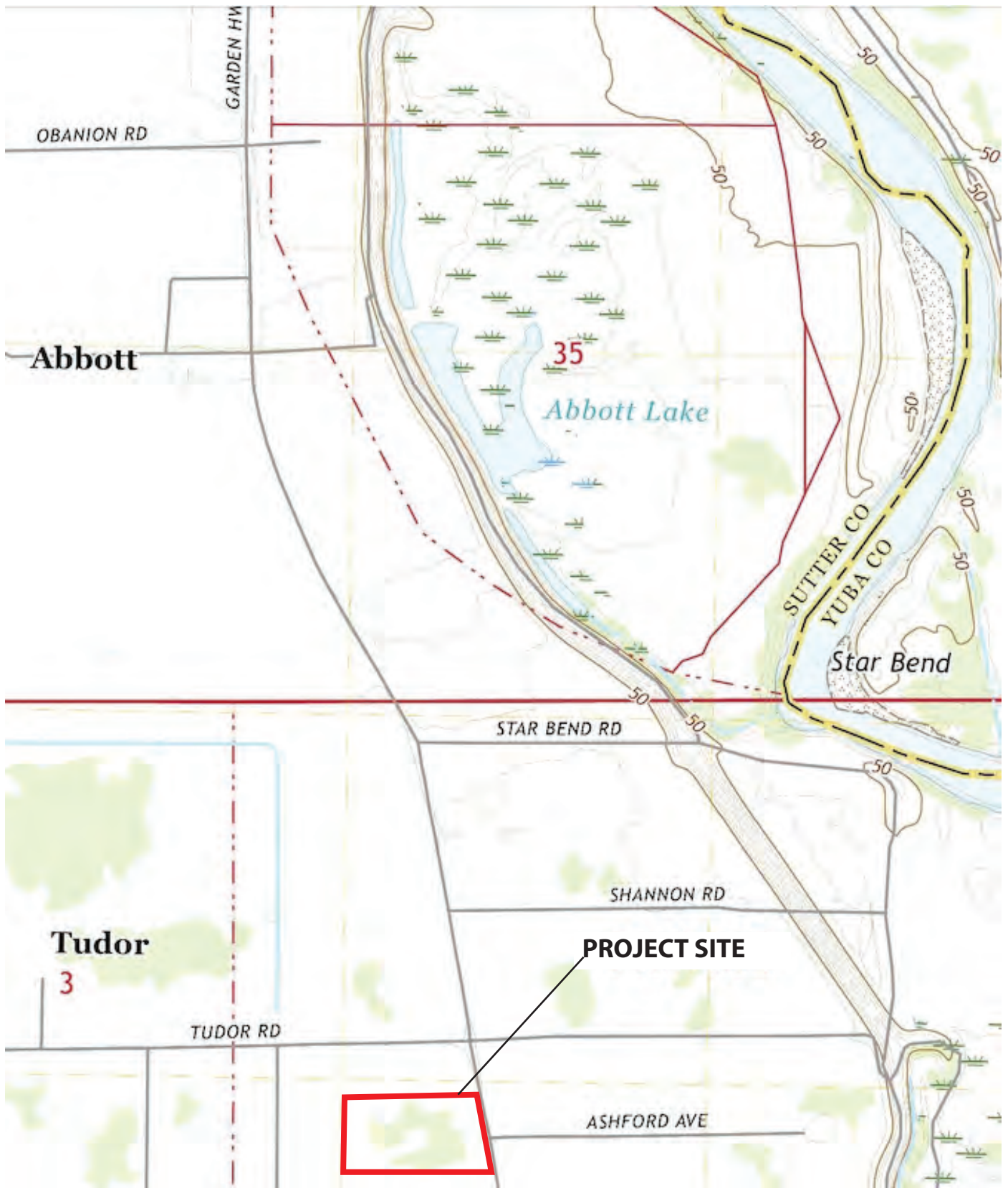

**SOURCE:** USGS Quadrangle Map, Olivehurst, CA 2021

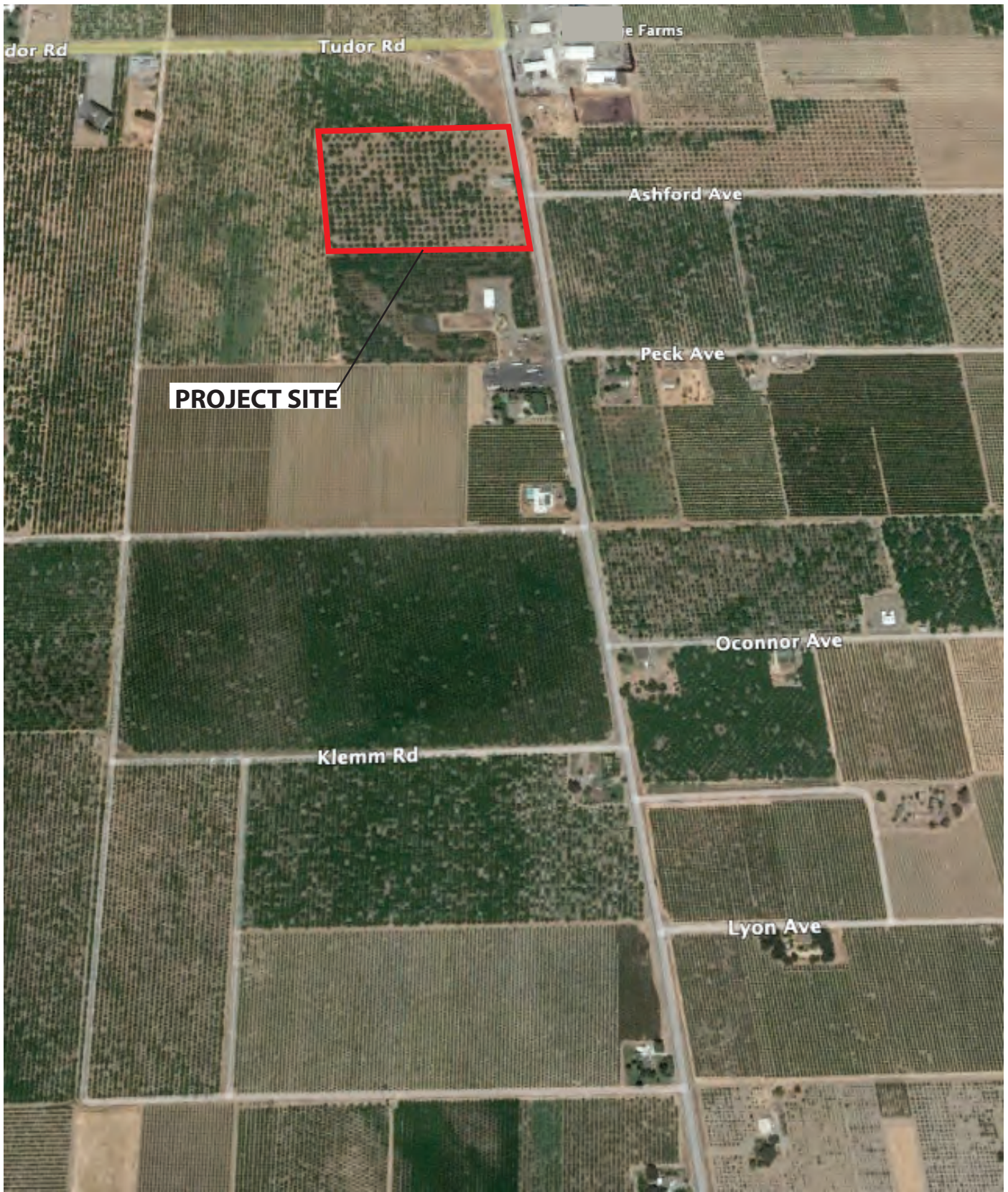

SOURCE: Google Earth

POR. NEW HELVETIA RANCHO  
 S 1/2 SEC. 2 POR. SW 1/4 SEC. 1, T.13 N., R.3 E., M.D.B. & M. EXT.

25-09

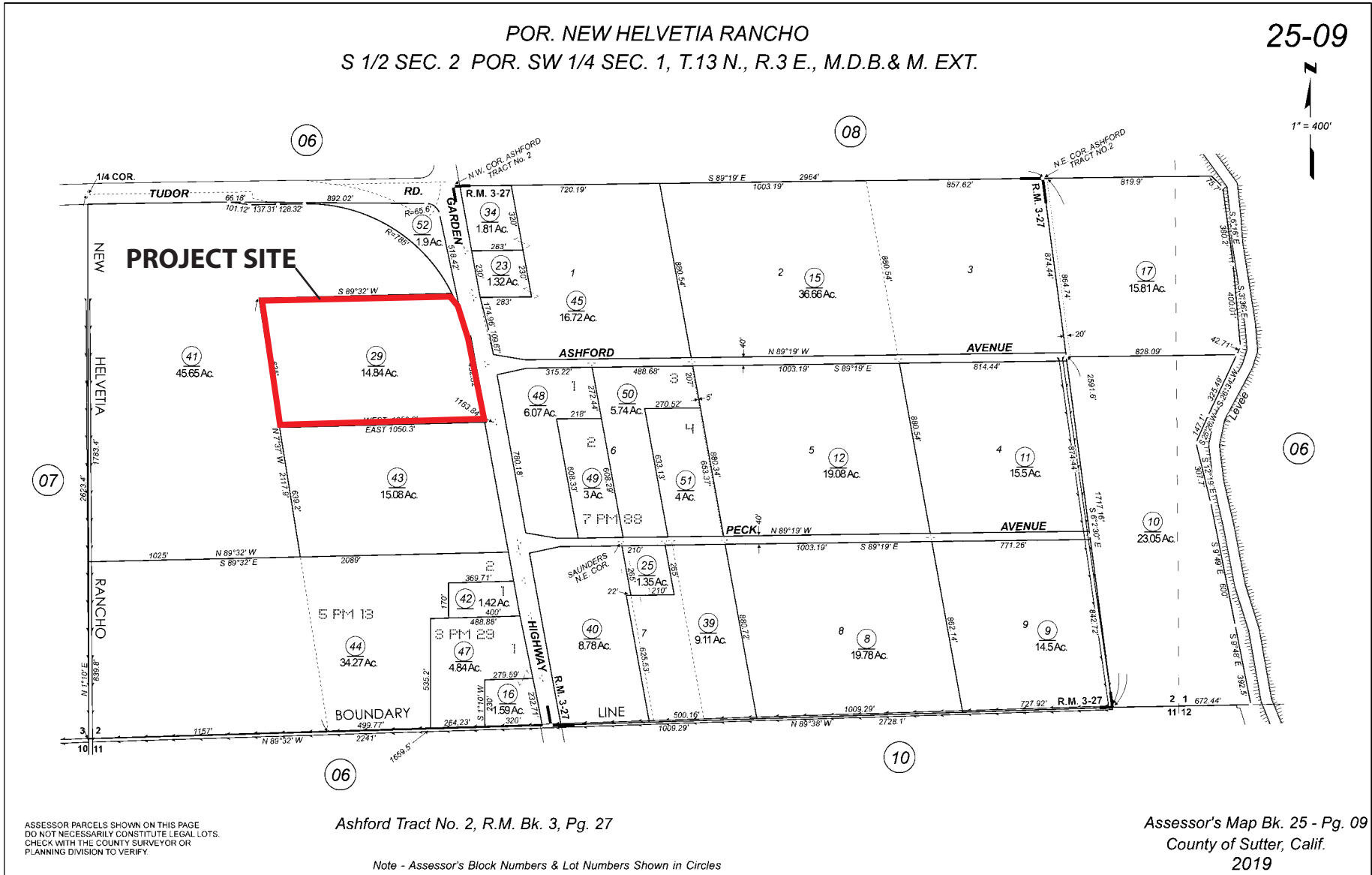
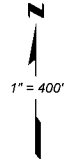

**ZONING CRITERIA:**  
 ZONING: AG  
 GENERAL PLAN: AG (80 AC. MIN.)  
 TOTAL SITE AREA: 14.08 ACRES  
 FLOOD ZONE: LOCAL FLOOD HAZARD AREA

- C1.0 SITE PLAN (w/O IMAGE)
- C1.1 SITE PLAN (w/ IMAGE)
- C1.2 ARCHITECTURAL SITE PLAN
- C2 TRUCK TURNING PLAN
- C3 TRUCK TURNING PLAN
- C4 GRADING AND DRAINAGE PLAN
- L1 LANDSCAPING PLAN
- P1 PHOTOMETRIC PLAN
- P2 PHOTOMETRIC DETAILS

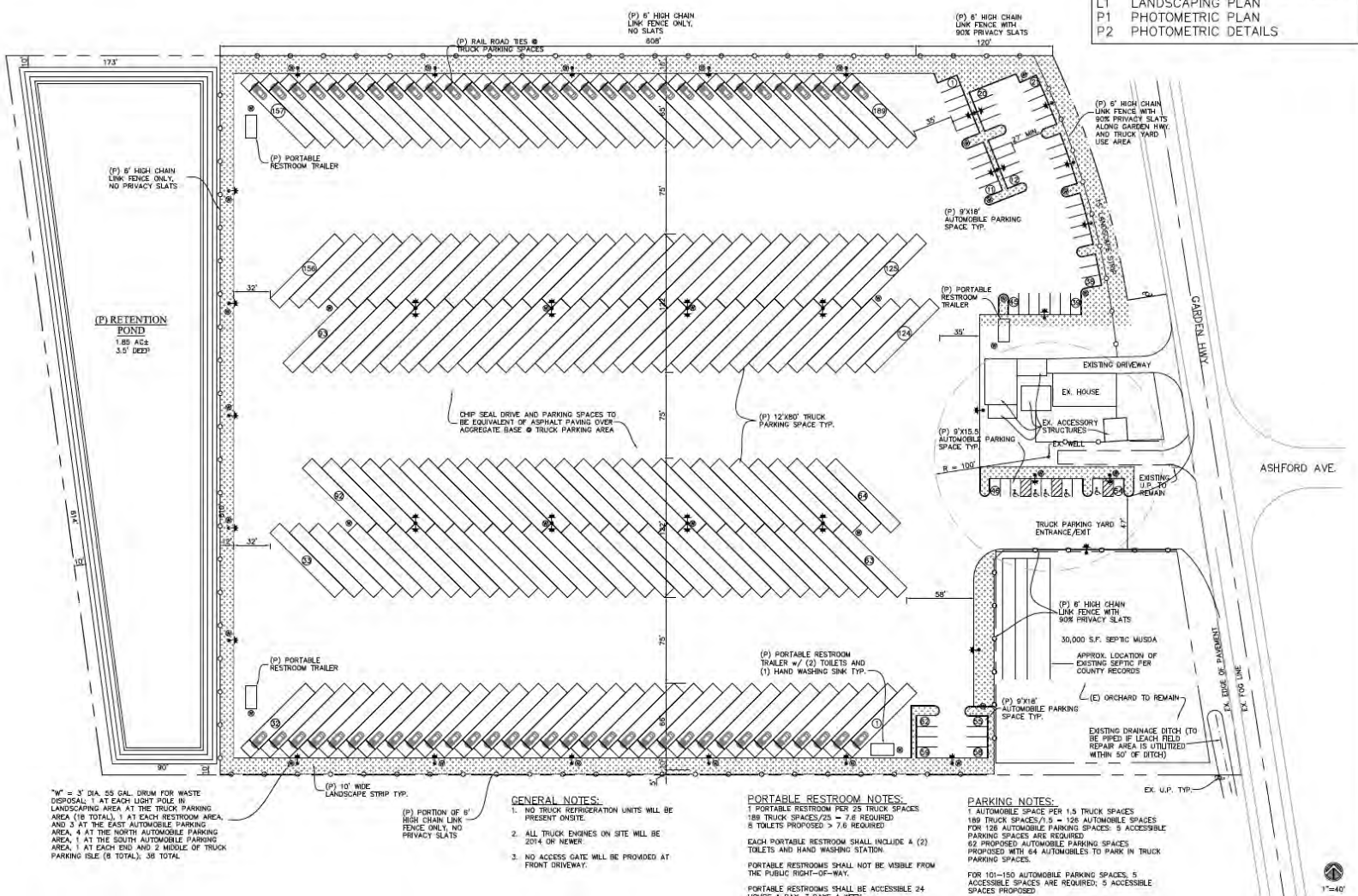

# CHECKLIST

## I. AESTHETICS

Except as provided in Public Resources Code Section 21099, would the project:	Potentially Significant Impact	Less Than Significant with Mitigation Incorporated	Less Than Significant Impact	No Impact
a) Have a substantial adverse effect on a scenic vista?				✓
b) Substantially damage scenic resources, including, but not limited to, trees, rock outcroppings, and historic buildings within a state scenic highway?				✓
c) In non-urbanized areas, substantially degrade the existing visual character or quality of public views of the site and its surroundings? (Public views are those that are experienced from publicly accessible vantage point.) If the project is in an urbanized area, would the project conflict with applicable zoning and other regulations governing scenic quality?			✓	
d) Create a new source of substantial light or glare which would adversely affect day or nighttime views in the area?			✓	

### Responses:

a) **No impact.** This project would not have a substantial adverse effect on a scenic vista. The General Plan does not inventory any scenic vista on the subject property and there are no scenic vistas proximate to the project site. The General Plan Technical Background Report identifies geographic features such as the Sutter Buttes, Feather River, Sacramento River, and Bear River as scenic resources within the County. This project is not located within the Sutter Buttes Overlay Zone and is not located in the immediate vicinity of the Bear River, Feather River, or Sacramento River. As a result, this project would have no impact on scenic vistas.

b) **No impact.** This project would not substantially damage scenic resources, including, but not limited to, trees, rock outcroppings, and historic buildings within a state scenic highway, because there are no state scenic highway designations in Sutter County. As there are no scenic highways located in Sutter County, no impact is anticipated.

c) **Less than significant impact.** The proposed project is in a non-urbanized area and would not substantially degrade the existing visual character or quality of public views of the site and its surroundings. The surrounding area is rural. While truck parking is not a typical land use associated with the area, the project would be consistent with activities in the area that use trucks, such as agricultural processing plants. The project would result in removal of existing orchard land. However, only a limited orchard view is available from Garden Highway and some trees would be retained; thus, changes in the landscape from Garden Highway would not be substantial.

The County's Zoning Code contains specific requirements for screening for large general truck yards proposed within the AG District (Zoning Code Section 1500-05-030 E. 3. o.). These requirements specify that facilities shall be screened from view through concrete

masonry unit walls or chain-link fencing with privacy slats, having a minimum privacy rating of 90 percent or greater and landscaping. The Zoning Code also specifies that facilities shall comply with the applicable requirements of Zoning Code Table 1500-07-3 (Commercial and Employment Design Checklist), which includes requirements for landscaping and screening.

As described in the Project Description, a six-foot-high chain link fence with privacy slats having a 90 percent screening ability will be provided along Garden Highway as well as a portion of the north property line as denoted on the site plan. The remainder of the site will have a six-foot-high chain link fence along the property line without slats adjacent to the proposed truck parking area.

Landscaping would include trees and shrubs planted along the frontage of the property and at the proposed light vehicle parking spaces. Landscaping consisting of trees also would be installed along the northern and southern boundaries of the project site. Shrubs are proposed along the west side of the truck parking area. Areas along Garden Highway between the property frontage fence and front property line not landscaped would be treated for weed control. The applicant has submitted a landscape plan (Appendix A), which demonstrates compliance with Zoning Code requirements for landscaping. All landscaping was selected from the County's Preferred Landscape Plant Materials List. Fencing and landscaping is required to be installed in accordance with the site plan and landscape plan prior to use of the site for truck and trailer and vehicle parking and would be continuously maintained, which will be included as a proposed project condition. As this project complies with the design requirements of the Zoning Code, this project is not anticipated to substantially degrade the existing visual character or quality of the site or its surroundings. A less-than-significant impact is anticipated.

d) **Less than significant impact.** This project would not create a new source of substantial light or glare which would adversely affect day or nighttime views in the area. Existing lighting is limited to exterior lighting of the onsite residence, and the project would add new lighting for the truck yard.

The County's Zoning Code contains specific requirements for exterior lighting for large general truck yards proposed within the AG District (Zoning Code Section 1500-05-030 E. 3. d.). These requirements specify that light pole and fixture height shall not exceed 25 feet and that truck parking areas shall incorporate motion-activated lighting that shall not spill onto adjoining properties. These requirements also specify that exterior lighting shall be provided consistent with Zoning Code Table 1500-07-3 (Commercial and Employment Design Checklist). These requirements specify that luminaries be oriented and shielded to direct the light downward onto the property and not spill onto adjacent properties or road rights-of-way. The requirements also specify illumination requirements for parking lots and driveways and require that a point-by-point exterior lighting (photometric) plan be submitted to demonstrate compliance with the lighting standards. The applicant has submitted an exterior lighting (photometric) plan, demonstrating compliance with these requirements.

As described in the Project Description, proposed lighting fixtures would not exceed 25 feet in height and lights would be motion-activated. Therefore, the project would comply with the Zoning Code requirements for lighting. Outdoor lighting is required to be installed in accordance with the lighting plan prior to use of the site for truck/trailer and vehicle parking, which will be included as a proposed project condition. In addition, there are few

land uses in the area that would be sensitive to changes in illumination levels, and orchard trees in the area would screen out the lighting generated from the project site. As a result, it is not anticipated this project would create a new source of substantial light or glare in this area. A less-than-significant impact is anticipated.

(Caltrans, California State Scenic Highways. 2022)

(County of Sutter, General Plan Technical Background Report. 2008)

(County of Sutter, Zoning Code. 2022)

## II. AGRICULTURE AND FORESTRY RESOURCES

<p>In determining whether impacts to agricultural resources are significant environmental effects, lead agencies may refer to the California Agricultural Land Evaluation and Site Assessment Model (1997) prepared by the California Dept. of Conservation as an optional model to use in assessing impacts on agriculture and farmland. In determining whether impacts to forest resources, including timberland, are significant environmental effects, lead agencies may refer to information compiled by the California Department of Forestry and Fire Protection regarding the state's inventory of forest land, including the Forest and Range Assessment Project and the Forest Legacy Assessment Project; and forest carbon measurement methodology provided in Forest Protocols adopted by the California Air Resources Board. Would the project:</p>	Potentially Significant Impact	Less Than Significant with Mitigation Incorporated	Less Than Significant Impact	No Impact
<p>a) Convert Prime Farmland, Unique Farmland, or Farmland of Statewide Importance (Farmland), as shown on the maps prepared pursuant to the Farmland Mapping and Monitoring Program of the California Resources Agency, to non-agricultural use?</p>			✓	
<p>b) Conflict with existing zoning for agricultural use, or a Williamson Act contract?</p>			✓	
<p>c) Conflict with existing zoning for, or cause rezoning of, forest land (as defined in Public Resources Code Section 12220(g)), timberland (as defined by Public Resources Code Section 4526), or timberland zoned Timberland Production (as defined by Government Code Section 51104(g))?</p>				✓
<p>d) Result in the loss of forest land or conversion of forest land to non-forest use?</p>				✓
<p>e) Involve other changes in the existing environment, which, due to their location or nature, could result in conversion of Farmland to non-agricultural use or conversion of forest land to non-forest use?</p>			✓	

## Responses:

a) **Less than significant impact.** This project would convert approximately 14 acres of Farmland, as shown on the maps prepared pursuant to the Farmland Mapping and Monitoring Program (FMMP) of the California Resources Agency, to a non-agricultural use. As shown on the 2018 Sutter County Important Farmland map, the entire project site, except for the residence area, is designated as “Prime Farmland.” The project would convert Prime Farmland to a non-agricultural use.

The Sutter County General Plan Environmental Impact Report (EIR) identified the conversion of Farmland resulting from development under the General Plan (similar to this project) as a potentially significant impact. To minimize conversion impacts, General Plan Policy AG 1.5 discourages the conversion of agricultural land to other uses unless the following findings can be made: (1) the net community benefit derived from conversion of the land outweighs the need to protect the land for long-term agricultural use; (2) there are no feasible alternative locations for the proposed use that would appreciably reduce impacts upon agricultural lands; and (3) the use would not have significant adverse effects, or can mitigate such effects, upon existing and future adjacent agricultural lands and operations.

The project would provide parking spaces for trucks, some of which may be used by agricultural trucks, which could support agricultural activities in the area. The project would have no impact on existing adjacent agricultural lands and operations. The truck parking yard would be within an existing parcel and would not require encroachment on adjacent lands. As noted in b) below, the existing AG zoning allows for the proposed project with approval of a use permit.

Therefore, while the project would convert Farmland to non-agricultural use, this conversion would be consistent with existing AG zoning and the Sutter County General Plan EIR development assumptions, and agricultural land in the vicinity would not be impacted and would remain available for farming. A less-than-significant impact is anticipated.

b) **Less than significant impact.** This project would not conflict with existing zoning for agricultural uses or a Williamson Act contract. The project site is zoned AG. The AG zoning designations permits truck yards, such as the proposed project, with a use permit. The project site is not under a Williamson Act contract. A less-than-significant impact is anticipated.

c) **No impact.** This project would not conflict with existing zoning for, or cause rezoning of, forest land (as defined in Public Resources Code Section 12220(g)), timberland (as defined by Public Resources Code Section 4526), or timberland zoned Timberland Production (as defined by Government Code Section 51104(g)), because the project site and surrounding area does not contain forest land. The project site is not zoned for forest land or timberland nor is it adjacent to land that is zoned for forest land or timberland. This project is located in the Sacramento Valley, a non-forested region. There would be no impact.

d) **No Impact.** This project would not result in the loss of forest land or conversion of forest land to a non-forest use because of its location within Sutter County. Sutter County is

located on the valley floor of California’s Central Valley, and, as such, does not contain forest land. No impact is anticipated.

e) **Less than significant impact.** This project would not involve other changes to the existing environment which could result in the conversion of farmland to a non-agricultural use or conversion of forest land to a non-forest use. This project proposes a large general truck yard. Conflicts between the proposed project and agricultural uses in the vicinity are not anticipated. Agricultural uses in the vicinity would continue. This project does not propose infrastructure or other features that would present an opportunity for the conversion of farmland in the vicinity to a non-agricultural use. As noted in d), there is no forest land in Sutter County, so there would be no opportunity to convert forest land to non-forest use. Therefore, a less-than-significant impact is anticipated.

(California Dept. of Conservation, Farmland Mapping and Monitoring Program. 2018)

(County of Sutter, General Plan Draft Environmental Impact Report. 2008)

(County of Sutter, Zoning Code. 2022)

### III. AIR QUALITY

Where available, the significance criteria established by the applicable air quality management district or air pollution control district may be relied upon to make the following determinations. Would the project:	Potentially Significant Impact	Less Than Significant with Mitigation Incorporated	Less Than Significant Impact	No Impact
a) Conflict with or obstruct implementation of the applicable air quality plan?		✓		
b) Result in a cumulatively considerable net increase of any criteria pollutant for which the project region is non-attainment under an applicable federal or state ambient air quality standard?			✓	
c) Expose sensitive receptors to substantial pollutant concentrations?			✓	
d) Result in other emissions (such as those leading to odors) adversely affecting a substantial number of people?			✓	

#### Responses:

a) **Less than significant with mitigation incorporated.** This project would not conflict with or obstruct implementation of an applicable air quality plan. Both the federal and State governments have established ambient air quality standards, based on their respective Clean Air Acts, for various air pollutants identified as “criteria” air pollutants. The federal Clean Air Act identifies six criteria pollutants: reactive organic gases (ROG), nitrogen oxides (NOx), carbon monoxide (CO), sulfur dioxide, lead, and particulate matter less than 10 micrometers in diameter (PM10), a subset of which is particulate matter less than 2.5 micrometers in diameter (PM2.5). The California Clean Air Act identifies these six federal criteria pollutants, along with four others.

Under both Clean Air Acts, air basins are classified as being in “attainment” or “nonattainment” of these ambient air quality standards, or they are “unclassified”. Any air

district that has been designated as a nonattainment area relative to federal and/or State ambient air quality standards for ozone, CO, sulfur dioxide or nitrogen dioxide is required to prepare and submit a plan for attaining and maintaining the standards for which it is in nonattainment.

The project site is within the boundaries of the Feather River Air Quality Management District (FRAQMD), which covers both Sutter and Yuba Counties. The FRAQMD is either in attainment of or unclassified for all federal and State ambient air quality except for federal standards for ozone and PM10. Portions of Sutter County are also in nonattainment of State standards for ozone. The FRAQMD, in cooperation with other air districts in the northern Sacramento Valley, has prepared the Northern Sacramento Valley Planning Area Air Quality Attainment Plan for the attainment of State ozone standards. Plans have also been prepared for the attainment of federal ozone and PM10 standards.

To determine air quality impacts resulting from the proposed project, the applicant hired Environmental Permitting Specialists to prepare an air quality analysis. A copy of this analysis is included as Appendix B to this Initial Study. The air quality analysis describes existing air quality in the project area and the surrounding region, details the associated regulatory setting, and presents an analysis of potential impacts of air pollutant emissions from project construction and operation on air quality. The analysis was reviewed by FRAQMD, which had no comment other than to ask if TRUs would be part of the project. As noted in Chapter 1.0, Project Description, TRUs would not be involved.

The significance of the impacts was determined using emission thresholds established by FRAQMD for ROG and NOx, the main ingredients for ozone, as well as for PM10. Table 1 below shows the FRAQMD significance thresholds. These thresholds have been established only for the criteria pollutants for which FRAQMD is in nonattainment status.

**TABLE 1  
FRAQMD SIGNIFICANCE THRESHOLDS AND PROJECT EMISSIONS**

	ROG	NO <sub>x</sub>	PM <sub>10</sub>
<b>Significance Thresholds (pounds/day)<sup>1</sup></b>	<b>25<sup>2</sup></b>	<b>25<sup>2</sup></b>	<b>80</b>
Construction Emissions (pounds/day)	7.55	4.74	13.31
Construction Emissions (tons/year)	0.11	0.07	0.20
<i>Exceeds threshold?</i>	<i>No</i>	<i>No</i>	<i>No</i>
Operational Emissions (pounds/day)	0.47	11.63	0.21
<i>Exceeds threshold?</i>	<i>No</i>	<i>No</i>	<i>No</i>

<sup>1</sup> Applies to both construction and operational emissions.

<sup>2</sup> Construction emissions not to exceed 4.5 tons per year.

### Short-Term Construction Impacts

Construction activities for the proposed project would emit criteria air pollutants from a variety of activities, including operation of heavy equipment and use of worker vehicles, vendor trucks, and hauling trucks. Emissions of ozone precursors (ROG and NOx) are primarily generated by mobile sources and largely vary as a function of vehicle trips per day and the type, quantity, intensity, and frequency of heavy-duty, off-road equipment

used. Typically, a large portion of construction-related ROG emissions results from the application of asphalt on to parking areas, and the application of architectural coatings. Construction-related fugitive dust emissions of PM10 would vary from day to day, depending on the level and type of activity, silt content of the soil, and the weather.

As part of the air quality analysis for the project, construction emissions were estimated using the California Emissions Estimator Model (CalEEMod) Version 2020.4.0. Estimated construction emissions for the proposed project are reported and compared to the FRAQMD thresholds of significance in Table 1 above. As shown in Table 1, emissions of NOx, ROG, and PM10 generated during construction of the proposed project will not exceed FRAQMD thresholds of significance. Therefore, project construction activities will not interfere with the implementation of air quality attainment plans for ozone or PM10. Project construction impacts on air quality will be less than significant.

### Long-Term Operational Impacts

The proposed project would result in long-term operational emissions, as it would generate an increase in the number of trucks that would travel to and from the site on a regular basis. The air quality analysis used the EMFAC 2021 computer model to estimate vehicle exhaust emissions and data from the California Air Resources Board (CARB) to estimate fugitive road dust emissions. The results of this analysis are summarized and compared to the FRAQMD operational thresholds of significance in Table 1 above. As shown in Table 1, total project operational emissions would not exceed the FRAQMD thresholds of significance for emissions of ROG, NOx, or PM10. Therefore, project operations would not interfere with the implementation of air quality attainment plans for ozone or PM10.

Since the proposed project has an operational phase, the project is characterized by FRAQMD as a Type 1 project. According to the FRAQMD indirect source review guidelines, if operational emissions of a Type 1 project do not exceed the thresholds of significance, it is recommended that the project proponent implement the Standard Mitigation Measures. These include the implementation of a Fugitive Dust Control Plan to control dust emissions during construction activities. The project would implement the following mitigation measure, which requires the application of the FRAQMD Standard Mitigation Measures.

**Mitigation Measure No. 1 (Air Quality):** IMPLEMENT FEATHER RIVER AIR QUALITY MANAGEMENT DISTRICT (FRAQMD) STANDARD MITIGATION MEASURES. The project applicant shall implement the following FRAQMD-recommended Standard Mitigation Measures for projects that do not exceed construction or operational thresholds of significance.

- Implement the Fugitive Dust Control Plan prior to any on-site grading, landscaping, or construction activities. The applicant shall submit the fugitive dust control plan to the FRAQMD for review and approval. A copy of the approved plan shall be submitted to the Development Services Department.
- Construction equipment exhaust emissions shall not exceed FRAQMD Regulation III, Rule 3.0, Visible Emissions limitations (40 percent opacity or Ringlemann 2.0).

- The contractor shall be responsible to ensure that all construction equipment is properly tuned and maintained prior to and for the duration of onsite operation.
- Limit idling time to 5 minutes – saves fuel and reduces emissions in accordance with 13 California Code of Regulations (CCR) Chapter 10 Section 2485 and 13 CCR Chapter 9 Article 4.8 Section 2449.
- Utilize existing power sources or clean fuel generators rather than temporary power generators.
- Develop traffic plans to minimize traffic flow interference from construction activities. The plan may include advance public notice of routing, use of public transportation, and satellite parking areas with a shuttle service. Schedule operations affecting traffic for off-peak hours. Minimize obstruction of through-traffic lanes. Provide a flag person to guide traffic properly and ensure safety at construction sites.
- Portable engines and portable engine-driven equipment units used at the project work site, with the exception of on-road and off-road motor vehicles, may require CARB Portable Equipment Registration with the State or a local district permit. The owner/operator shall be responsible for arranging appropriate consultation with CARB or FRAQMD to determine registration and permitting requirements prior to equipment operation at the site.

Overall, because this project would not generate emissions above FRAQMD's thresholds of significance for construction and operational activities and would implement the relevant mitigation listed above, a less-than-significant impact on air quality is anticipated.

b) **Less than significant impact.** The focus of the analysis is related to the ground-level ozone and PM10, for which FRAQMD is in non-attainment. PM2.5, CO, and SO2 were not a component of the analysis, since FRAQMD does not have numerical thresholds of significance for these pollutants, and in any case FRAQMD is in attainment of standards for these pollutants. This project's cumulative impacts regarding air quality are discussed in the Mandatory Findings of Significance Section of this checklist.

Neither construction nor operation of the proposed project would generate emissions that would exceed the FRAQMD thresholds of significance, and the project would implement the FRAQMD recommended Standard Mitigation Measures. Therefore, the project would not result in a significant net increase of criteria air pollutant for which the project region is non-attainment under an applicable federal or state ambient air quality standard. A less-than-significant impact is anticipated.

c) **Less than significant impact.** This project would not expose sensitive receptors to substantial pollutant concentrations. The nearest potential sensitive receptor is a residential building on the east side of Garden Highway approximately 110 meters (410 feet) north of the proposed site entrance. As discussed in a) above, project construction and operational emissions would not exceed FRAQMD significance thresholds. As such, the nearby sensitive receptors would not be exposed to substantial amounts of pollutant emissions, especially when Mitigation Measure No. 1 is implemented.

The project would generate emissions of diesel particulate matter (DPM), which is considered a toxic air contaminant that could lead to increased cancer risk with prolonged exposure. DPM emissions would be generated by the operation of off-road construction equipment (e.g., excavators, loaders, cranes, graders) and on-road diesel heavy-duty vehicles.

The air quality analysis for the project included a health risk assessment that evaluated the potential health risks to the nearby residences of the estimated DPM operational emissions. The health risk assessment is available in Appendix B of this document. Construction DPM emissions were not considered, as these emissions are temporary and measurable health risks from DPM emissions occur only with prolonged exposure. The emission rate of exhaust PM10 estimated by CalEEMod, with a few refinements, is considered a surrogate for DPM. DPM operational emissions generated by the project were estimated at 0.328 pounds per year. While the truck yard would be open all year, trucks would only operate 60 days out of the year, per information from the project applicant. Therefore, 60 days were used to calculate the emissions used in calculating the cancer risks.

Toxic air contaminant emissions are considered significant if the emissions lead to a cancer risk of 10 cancers per million people and the Non-Cancer Hazard Index is 1.0. The air quality analysis found that for the closest distance to the project site (0 to 100 meters), the cancer risk would be approximately 0.758 per million – well below the significance threshold for cancer risk. The Non-Cancer Hazard Index at 0 to 100 meters would be 0.0011, also well below the significance threshold.

In summary, construction and operational emissions from the proposed project would not generate substantial criteria pollutant emissions, nor would it generate DPM emissions that would pose a substantial health risk to nearby residences (sensitive receptors). Therefore, the project would not expose sensitive receptors to substantial pollutant concentrations, and the impact is considered less than significant.

d) **Less than significant impact.** This project would not result in other emissions, such as those leading to odors, adversely affecting a substantial number of people. FRAQMD has identified various types of facilities that are known sources of odors, including wastewater treatment plants, sanitary landfills, painting/coating operations, food processing facilities, and green waste and recycling operations. The proposed project would not include operation of any of these types of odor-generating facilities. Therefore, the project would not be anticipated to generate odors that would affect a substantial number of people, and the impact would be less than significant.

(Environmental Permitting Specialists, Draft Analysis of Impacts to Air Quality and Greenhouse Gas from Proposed Truck Yard, Yuba City, California. 2022)

(Feather River Air Quality Management District, Indirect Source Review Guidelines. 2010)

(County of Sutter, General Plan 2030. 2011)

#### IV. BIOLOGICAL RESOURCES

Would the project:	Potentially Significant Impact	Less Than Significant with Mitigation Incorporated	Less Than Significant Impact	No Impact
a) Have a substantial adverse effect, either directly or through habitat modifications, on any species identified as a candidate, sensitive, or special status species in local or regional plans, policies or regulations, or by the California Department of Fish and Wildlife or U.S. Fish and Wildlife Service?			✓	
b) Have a substantial adverse effect on any riparian habitat or other sensitive natural community identified in local or regional plans, policies, or regulations, or by the California Department of Fish and Wildlife or U.S. Fish and Wildlife Service?				✓
c) Have a substantial adverse effect on state or federally protected wetlands (including, but not limited to, marsh, vernal pool, coastal, etc.) through direct removal, filling, hydrological interruption, or other means?				✓
d) Interfere substantially with the movement of any native resident or migratory fish or wildlife species or with established native resident or migratory wildlife corridors, or impede the use of native wildlife nursery sites?			✓	
e) Conflict with any local policies or ordinances protecting biological resources, such as a tree preservation policy or ordinance?				✓
f) Conflict with the provisions of an adopted Habitat Conservation Plan, Natural Community Conservation Plan, or other approved local, regional, or state habitat conservation plan?				✓

#### Responses:

a) **Less than significant impact.** This project would not have a substantial adverse effect, either directly or through habitat modifications, on any species identified as a candidate, sensitive, or special status species in local or regional plans, policies, or regulations, or by the California Department of Fish and Wildlife (CDFW) or U.S. Fish and Wildlife Service (USFWS). The General Plan EIR assessed the presence of special-status species in Sutter County through a search of the California Natural Diversity Database maintained by CDFW. The results indicate no candidate, sensitive, or special-status species identified as potentially occurring onsite or in the immediate area. According to current California Natural Diversity Database data, there are no candidate, sensitive, or special status species identified as potentially occurring onsite or in the immediate area. The nearest special status species identified are located adjacent to the Feather River approximately one mile east of the site. This project was circulated to CDFW for review, and they did not provide any comments. In addition, the USFWS Critical Habitat Mapper indicated no critical habitat for any species listed under the federal Endangered Species Act within the project site and vicinity.

The project site is being used for orchards. Sites that have been used agriculturally and that were previously developed are generally of limited use to wildlife due to the level of

disturbance and being devoid of native plant species or habitat. There are no waterways or wetlands on the project site in the project vicinity that may provide habitat for listed species. The uses occurring in the area are not conducive for wildlife to locate within the project site, and none have been inventoried. Therefore, a less-than-significant impact is anticipated.

b) **No impact.** This project would not have a substantial adverse effect on any riparian habitat or other sensitive natural community identified in local or regional plans, policies, regulations, or by the CDFW or USFWS. There are no streams or rivers on the project site in the immediate vicinity. No riparian habitat or other sensitive natural community exists onsite or near the property. The site is surrounded by orchard land. Therefore, no impact is anticipated.

c) **No impact.** This project would not have a substantial adverse effect on state or federally protected wetlands (including, but not limited to, marsh, vernal pool, coastal, etc.) through direct removal, filling, hydrological interruption, or other. As noted, there are no streams or rivers in the vicinity, and the project site consists of orchard. No wetlands were identified on the project site by the National Wetlands Inventory of the USFWS. Therefore, no impact is anticipated.

d) **Less than significant impact.** This project would not interfere substantially with the movement of any native resident or migratory fish or wildlife species or with established native resident or migratory wildlife corridors or impede the use of a native wildlife nursery site because the area is predominantly orchards. The project is not anticipated to significantly interfere with wildlife movement since the site is an existing orchard and is surrounded by active agricultural operations that discourage wildlife movement. The property is not located near any rivers or streams that would provide fish movement corridors. Only orchard and ornamental trees are in the project vicinity, which are not considered desirable nesting sites for migratory birds, particularly since the Feather River riparian area is east of the project site. A less-than-significant impact is anticipated.

e) **No impact.** This project would not conflict with any local policies or ordinances protecting biological resources, such as a tree preservation policy or ordinance, because Sutter County has not adopted such policies or ordinances. There are no oak trees located on the project site. There would be no impact.

f) **No impact.** The proposed project would not conflict with the provisions of an adopted Habitat Conservation Plan, Natural Community Conservation Plan, or other approved local, regional, or state habitat conservation plan because no such plans are applicable to this project site. As a result, no impacts are anticipated.

(County of Sutter, General Plan Draft Environmental Impact Report. 2008)

(County of Sutter, General Plan Technical Background Report. 2008)

(U.S. Fish and Wildlife Service, Critical Habitat Mapper, 2022)

(U.S. Fish and Wildlife Service, National Wetlands Inventory, 2022)

## V. CULTURAL RESOURCES

Would the project:	Potentially Significant Impact	Less Than Significant with Mitigation Incorporated	Less Than Significant Impact	No Impact
a) Cause a substantial adverse change in the significance of a historical resource pursuant to Section 15064.5?		✓		
b) Cause a substantial adverse change in the significance of an archaeological resource pursuant to Section 15064.5?		✓		
c) Disturb any human remains, including those interred outside of dedicated cemeteries?		✓		

### Responses:

a-b) **Less than significant with mitigation incorporated.** The proposed project would not cause a substantial adverse change in the significance of a historical resource or archaeological resource pursuant to California Environmental Quality Act (CEQA) Guidelines Section 15064.5. In Section 4.6 of the General Plan Technical Background Report, Figure 4.6-1 does not list the property as being a historic site. The site is not listed on the National Register of Historic Places. There are no unique features or historical resources located on the project site and the project does not propose the removal of the existing buildings. The project site is not located within the vicinity of the Bear River, Sacramento River, or Feather River, where archaeological resources are more likely to occur. There is no evidence on the project site indicating that historical or archaeological resources exist.

The project site has been used agriculturally and continues to have this use. Since the property has been extensively disturbed to varying depths due to agricultural uses, it is unlikely that any intact cultural resources exist. Nevertheless, it is conceivable that archaeological resources could be encountered during project construction. To mitigate potential impacts, a mitigation measure is proposed to prevent disturbance of human remains should they be encountered.

**Mitigation Measure No. 2 (Cultural Resources):** If archaeological resources are discovered on the project site, potential ground disturbing activities within 100 feet of the find shall be halted immediately and the Development Services Department shall be notified. A qualified archaeologist shall examine the find and evaluate its significance. The archaeologist shall recommend measures needed to reduce effects on the cultural resource in a written report to the County. The County shall be responsible for implementing the report recommendations.

c) **Less than significant with mitigation incorporated.** The proposed project is not expected to disturb any human remains, including those interred outside of dedicated cemeteries. The property is not located near a cemetery. The project site is not located within the vicinity of the Bear River, Sacramento River, or Feather River, where burials are more likely to occur.

However, there is the potential to unearth human remains during project construction ground disturbing activities. California Health and Safety Code §7050.5 states that when human remains are discovered, no further site disturbance can occur until the County Coroner has made the necessary findings as to the origin of the remains and their

disposition pursuant to Public Resources Code Section 5097.98. If the remains are recognized to be those of a Native American, the coroner would contact the Native American Heritage Commission (NAHC) within 24 hours.

Public Resources Code §5097.98 states that whenever the NAHC receives notification of a discovery of Native American human remains from a county coroner, it shall immediately notify the most likely descendent from the deceased Native American. The descendants may inspect the site and recommend to the property owner a means for treating or disposing the human remains. If the NAHC cannot identify a descendent, or the descendent identified fails to make a recommendation, or the landowner rejects the recommendation of the descendent, the landowner shall rebury the human remains on the property in a location not subject to further disturbance.

To mitigate potential impacts, a mitigation measure is proposed to prevent disturbance of human remains should they be encountered.

**Mitigation Measure No. 3 (Cultural Resources):** If human remains are discovered on the site potentially ground disturbing activities within 100 feet of the remains shall be halted immediately, and the project applicant shall notify the Sutter County Coroner and Native American Heritage Commission (NAHC) immediately, according to Public Resources Code §5097.98 and Section 7050.5 of California’s Health and Safety Code. If the remains are determined by the NAHC to be Native American, the guidelines of the NAHC shall be adhered to in the treatment and disposition of the remains. The project applicant shall also retain a professional archaeologist with Native American burial experience to conduct a field investigation of the specific site and consult with the Most Likely Descendant, if any, identified by the NAHC. Following the coroner’s and NAHC’s findings, the archaeologist, and the NAHC-designated Most Likely Descendant shall determine the ultimate treatment and disposition of the remains and take appropriate steps to ensure that additional human interments are not disturbed. The responsibilities for acting upon notification of a discovery of Native American human remains are identified in Public Resources Code Section 5097.94.

(County of Sutter, General Plan Technical Background Report. 2008)

(National Park Service, National Register of Historic Places. 2021)

**VI. ENERGY**

Would the project:	Potentially Significant Impact	Less Than Significant with Mitigation Incorporated	Less Than Significant Impact	No Impact
a) Result in potentially significant environmental impact due to wasteful, inefficient, or unnecessary consumption of energy resources during project construction or operation?			✓	
b) Conflict with or obstruct a state or local plan for renewable energy or energy efficiency?			✓	

**Responses:**

a-b) **Less than significant impact.** The proposed project would not result in a potentially significant environmental impact due to wasteful, inefficient, or unnecessary consumption of energy resources during project construction or operation or conflict with or obstruct a state or local plan for renewable energy or energy efficiency. This project proposes a truck yard that would provide truck and automobile parking. No new buildings that would utilize energy are proposed.

Overall, the project would not require the creation of a new substantial source of energy generation. Construction of the parking area would require the consumption of diesel and gasoline to power construction equipment and delivery trucks. As stated in the greenhouse gas (GHG) analysis completed for this project, the project would take 60 days to construct. Additionally, construction equipment fleet turnover and increasingly stringent state and federal regulations on engine efficiency, combined with state regulations limiting engine idling times, would further reduce transportation fuel demand during project construction. There are no unusual construction processes that would be more energy-intensive than are used for comparable activities, and no equipment would be used that would not conform to current emissions standards and related fuel efficiencies. For these reasons, it is expected that fuel consumption associated with project construction would not be any more inefficient, wasteful, or unnecessary than other similar development projects of this nature within Sutter County.

Proposed outdoor lighting at the project site would use minimal energy. Lights would be LED fixtures on poles and would be operated by motion-activated sensors to further decrease energy use. Lighting would be required to comply with the energy requirements of the State Building Codes, including the California Energy Code (Part 6 of Title 24) related to lighting design and installation, luminaire, and lighting controls. The energy efficiency standards of the State of California are some of the most stringent in the nation. As a result, the project would not result in a wasteful, inefficient, or unnecessary consumption of energy resources, and a less-than-significant impact is anticipated.

**VII. GEOLOGY AND SOILS**

Would the project:				
a) Directly or indirectly cause potential substantial adverse effects, including the risk of loss, injury, or death involving:	Potentially Significant Impact	Less Than Significant with Mitigation Incorporated	Less Than Significant Impact	No Impact
i) Rupture of a known earthquake fault, as delineated on the most recent Alquist-Priolo Earthquake Fault Zoning Map issued by the State Geologist for the area or based on other substantial evidence of a known fault? Refer to Division of Mines and Geology Special Publication 42.				✓
ii) Strong seismic ground shaking?			✓	
iii) Seismic-related ground failure, including liquefaction?			✓	
iv) Landslides?				✓

b) Result in substantial soil erosion or the loss of topsoil?		✓		
c) Be located on a geologic unit or soil that is unstable, or that would become unstable as a result of the project, and potentially result in on- or off-site landslide, lateral spreading, subsidence, liquefaction or collapse?			✓	
d) Be located on expansive soil, as defined in Table 18-1-B of the Uniform Building Code (1994), creating substantial direct or indirect risks to life or property?			✓	
e) Have soils incapable of adequately supporting the use of septic tanks or alternative wastewater disposal systems where sewers are not available for the disposal of wastewater?			✓	
f) Directly or indirectly destroy a unique paleontological resource or site or unique geologic feature?			✓	

**Responses:**

a-i) **No impact.** This project would not directly or indirectly cause potential substantial adverse effects from rupture of a known earthquake fault, because the subject property is not located in an Alquist-Priolo Earthquake Fault Zone and would involve minor grading activities that would not exacerbate existing seismic hazards in the region. No impact is anticipated.

a-ii,-iii) **Less than significant impact.** This project would not directly or indirectly cause potential substantial adverse effects from strong seismic ground shaking or seismic-related ground failure, including liquefaction. Figure 5.1-1 in the General Plan Technical Background Report does not identify any active earthquake faults in Sutter County as defined by the California Mining and Geology Board. The faults identified in Sutter County include Quaternary faults in the northern section of the County within the Sutter Buttes and a pre-Quaternary fault in the southeastern corner of the County just east of where Highway 70 enters the County. Although both faults have the potential for seismic activity, they are listed as non-active faults. Therefore, the potential for earthquakes or liquefaction is unlikely, and a less-than-significant impact is anticipated.

a-iv) **No impact.** This project would not directly or indirectly cause potential substantial adverse effects from landslides. The project site is relatively level with no significant slope. In addition, the project is not located in the Sutter Buttes, the only area identified by the General Plan Technical Background Report as having landslide potential. Therefore, the potential for landslides is unlikely, and no impact is anticipated.

b) **Less than significant with mitigation incorporated.** This project would not result in substantial soil erosion or the loss of topsoil. According to the United States Department of Agriculture (USDA) Soil Conservation Service Soil Survey of the County, on-site soils consist solely of Conejo loam, 0 to 1 percent slopes. This soil is unlikely to be susceptible to erosion, because runoff is very slow and the hazard of water erosion is slight. The General Plan Technical Background Report indicates that soils with a 0 to 9 percent slope have only slight erodibility. However, site grading has the potential to result in soil erosion due to loosened soils.

Since the project size is more than one acre, the applicant is required to prepare a Storm Water Pollution Prevention Plan (SWPPP) and obtain a National Pollution Discharge Elimination System (NPDES) General Construction Permit through the Regional Water Quality Control Board (RWQCB) to ensure that soil is not released in storm water from the project site. To ensure that a less-than-significant impact occurs, the following mitigation measure is included, based on comments from the Development Services Engineering Division.

**Mitigation Measure No. 4 (Geology and Soils): STORM WATER QUALITY PROTECTION – DURING CONSTRUCTION.**

SWPPP - Prior to the start of construction, the applicant shall prepare and submit a Storm Water Pollution Prevention Plan (SWPPP) to be executed through all phases of grading and project construction. The SWPPP shall incorporate Best Management Practices (BMPs) to ensure that potential water quality impacts during construction phases are minimized. These measures shall be consistent with the County's Improvement Standards and Land Grading and Erosion Control Ordinance and the requirements of the National Pollution Discharge Elimination System (NPDES) General Permit for Storm Water Discharges Associated with Construction and Land Disturbance Activities. Prior to project construction the SWPPP shall be submitted to the County for review and to the Central Valley Regional Water Quality Control Board as required by the NPDES General Permit in effect during construction. During construction, the applicant shall implement actions and procedures established in the SWPPP to reduce the pollutant loadings in storm drain systems. The project applicant shall implement BMPs in accordance with the SWPPP and the County's Improvement Standards. The project applicant(s) shall submit a state storm water permit Waste Discharger Identification number for project construction.

NPDES GENERAL CONSTRUCTION PERMIT – Since the project size is more than one acre, prior to construction the applicant shall file a Notice of Intent with the Central Valley RWQCB to obtain coverage under the California State Water Resources - General Construction Activity Storm Water Permit. Permits are issued by the State Water Resources Control Board, which can provide all information necessary to complete and file the necessary documents. The applicant shall comply with the terms of the General Construction Permit, the County's ordinances, and the NPDES Waste Discharge Requirements for the Sutter County Phase II NPDES Permit.

c) **Less than significant impact.** This project is not located on a geological unit or soil that is unstable, or that would become unstable as a result of the project, and potentially result in on- or off-site landslide, lateral spreading, subsidence, liquefaction, or collapse. As stated above in b), soils at the site have a 0 to 1 percent slope with only a slight hazard of water erosion. The General Plan Technical Background Report indicates that soils with a 0 to 9 percent slope have slight erodibility. Also, as stated in a-iv), the project site has no landslide potential. A less-than-significant impact is anticipated.

d) **Less than significant impact.** This project is not located on expansive soils creating substantial direct or indirect risks to life or property. According to the USDA Soil Conservation Service Soil Survey of the County, Conejo loam has a low to moderate shrink-swell potential, with a low potential close to the surface. Project construction would

be required to comply with the adopted California Building Code, specifically Chapter 18 for soils conditions to address potential expansive soils. The project would result in development of a truck yard for parking. No buildings would be constructed as part of the project that would require foundations or specific design to address expansive soils. As the potential for soil expansion on the site is low and the project does not propose to construct any structures, a less-than-significant impact is anticipated.

e) **Less than significant impact.** An existing septic field is located on the project site at the southeast corner. However, as noted in the Project Description, portable toilets would be made available for driver use. The toilets would be self-contained and would be pumped as needed by a septic pumper registered with Sutter County. The existing septic field would not be used by the project.

In its comments on the project, the County Environmental Health Division stated the project will not interfere with the existing septic system serving the residence on the property. A 30,000 square foot Minimum Usable Sewage Disposal Area (MUSDA) has been shown in the southeast corner of the site to accommodate the existing septic system and reserve septic system replacement area. This area is proposed to be unimproved and protected from vehicular traffic by proposed chain-link fencing. As discussed with the project engineer, the septic system tight-line extending from the residence to the drainfield would be sleeved with appropriate material (i.e. steel) to prevent damage from vehicular traffic, which will be included as a proposed project condition.

f) **Less than significant impact.** The proposed project would not directly or indirectly destroy a unique paleontological resource or site or unique geologic feature. There are no known unique paleontological resources or unique geologic features located in the vicinity of the project. Implementation Program ER 8-D for policy ER 8.2 in the County General Plan requires that when paleontological resources are encountered, all work within 100 feet of the discovery shall be stopped and the area protected from further disturbance until the discovery is evaluated. The appropriate County personnel shall be notified immediately. The resource shall be examined by qualified personnel in accordance with SVP guidelines to determine their significance and to develop appropriate protection and preservation measures. A less-than-significant impact is anticipated.

(County of Sutter, General Plan Technical Background Report. 2008)

(USDA Soil Conservation Service, Sutter County Soil Survey. 1988)

(USDA Natural Resources Conservation Service, Custom Soil Survey, Sutter County. 2022)

## VIII. GREENHOUSE GAS EMISSIONS

Would the project:	Potentially Significant Impact	Less Than Significant with Mitigation Incorporated	Less Than Significant Impact	No Impact
a) Generate greenhouse gas emissions, either directly or indirectly, that may have a significant impact on the environment?			✓	
b) Conflict with an applicable plan, policy or regulation adopted for the purpose of reducing the emissions of greenhouse gases?			✓	

### Responses:

a) **Less than significant impact.** This project would not generate additional greenhouse gas (GHG) emissions, either directly or indirectly, that may have a significant impact on the environment. The Sutter County Climate Action Plan (CAP) was prepared and adopted in 2010 as part of the General Plan to ensure compliance with AB 32, also known as the Global Warming Solutions Act. Sutter County’s CAP includes a GHG inventory, an emission reduction target, and reduction measures to reach the target. The CAP also includes screening tables used to assign points for GHG mitigation measures. Projects that achieve 100 points or more do not need to quantify GHG emissions and are assumed to have a less-than-significant impact. Sutter County’s screening tables apply to all project sizes.

Small projects with little or no proposed development and minor levels of GHG emissions typically cannot achieve the 100-point threshold. Since the adoption of the CAP, further analysis to determine if a project can be too small to provide the level of GHG emissions reductions expected from the screening tables or alternative emissions analysis methods has been performed. In June 2016, Sutter County adopted new GHG Pre-Screening Measures to be applied to new projects. Sutter County has concluded that projects generating less than 3,000 metric tons of carbon dioxide equivalent (CO<sub>2</sub>e) would not require further GHG emissions analysis and are assumed to have a less-than-significant impact.

The Environmental Permitting Specialists air quality analysis for the project (see Appendix B) indicates that the project GHG emissions from vehicle traffic – the primary source for such emissions – would be approximately 283.3 metric tons CO<sub>2</sub>e per year. This is below the threshold of 3,000 metric tons CO<sub>2</sub>e per year. Other emission sources, such as lighting, would contribute only minimal GHG emissions. Based on this evaluation, the project would not generate GHG emissions that would have a significant impact on the environment. A less-than-significant impact is anticipated.

b) **Less than significant impact.** This project would not conflict with an applicable plan, policy, or regulation adopted for the purpose of reducing the emissions of greenhouse gases. As noted, Sutter County has adopted a CAP that screens projects based on a threshold of 3,000 metric tons CO<sub>2</sub>e per year. As noted in a) above, this project would not generate emissions that exceed this threshold. Therefore, this project would be consistent with the County CAP. A less-than-significant impact is anticipated.

(Environmental Permitting Specialists, Draft Analysis of Impacts to Air Quality and Greenhouse Gas from Proposed Truck Yard, Yuba City, California. 2022)

(County of Sutter, General Plan Technical Background Report. 2008)

(County of Sutter, General Plan 2030 Climate Action Plan. 2011)

(County of Sutter, Greenhouse Gas Pre-Screening Measures for Sutter County. June 28, 2016.)

## IX. HAZARDS AND HAZARDOUS MATERIALS

Would the project:	Potentially Significant Impact	Less Than Significant with Mitigation Incorporated	Less Than Significant Impact	No Impact
a) Create a significant hazard to the public or the environment through the routine transport, use, or disposal of hazardous materials?		✓		
b) Create a significant hazard to the public or the environment through reasonably foreseeable upset and accident conditions involving the release of hazardous materials into the environment?		✓		
c) Emit hazardous emissions or handle hazardous or acutely hazardous materials, substances, or waste within one-quarter mile of an existing or proposed school?				✓
d) Be located on a site which is included on a list of hazardous materials sites compiled pursuant to Government Code Section 65962.5 and, as a result, would it create a significant hazard to the public or the environment?				✓
e) For a project located within an airport land use plan or, where such a plan has not been adopted, within two miles of a public airport or public-use airport, would the project result in a safety hazard or excessive noise for people residing or working in the project area?				✓
f) Impair implementation of or physically interfere with an adopted emergency response plan or emergency evacuation plan?			✓	
g) Expose people or structures, either directly or indirectly, to a significant risk of loss, injury or death involving wildland fires?			✓	

### Responses:

a-b) **Less than significant with mitigation incorporated.** This project would not create a significant hazard to the public or the environment through the routine transport, use, or disposal of hazardous materials, or the creation of a significant hazard to the public or the environment through reasonably foreseeable upset and accident conditions involving the release of hazardous materials into the environment. The project is a truck parking area; therefore, it is not expected to use or discharge hazardous materials. The only hazardous materials of concern are small-scale fuel and oil discharges from vehicles. These deposits are minor and can be contained by a storm drainage system that would be in accordance with County requirements (see Section X, Hydrology and Water Quality).

Project site activities that would transport hazardous materials would be required to do so in compliance with applicable local, state, and federal regulations. These include the federal Resource Conservation and Recovery Act hazardous substance “cradle-to-grave” regulatory program that applies to transportation of hazardous materials, U.S. Department of Transportation regulations on the interstate transport of hazardous materials and wastes, and regulations of the state Department of Toxic Substances Control related to the transport of hazardous materials and waste.

The Development Services Environmental Health Division is the Certified Unified Program Agency (CUPA) for Sutter County, with responsibility for monitoring all uses involving the storage and handling of hazardous materials. Any business that uses, generates, processes, produces, treats, stores, emits, or discharges a hazardous material in quantities at or exceeding 55 gallons, 500 pounds, or 200 cubic feet (compressed gas) at any one time in the course of a year are required to submit a Hazardous Materials Business Plan. The primary purpose of the plan is to provide readily available information regarding the location, type, and health risks of hazardous materials to emergency response personnel, authorized government officials, and the public. The project is not expected to handle hazardous materials in an amount that would require submittal of a Hazardous Materials Business Plan.

All activities and uses must comply with State and County laws and regulations pertaining to the handling and disposal of all hazardous or acutely hazardous materials. The discharge of fuels, oils, other petroleum products, detergents, cleaners, chemicals, or compost materials to the surface of the ground or to drainage ways on or adjacent to the site is prohibited. The State of California has adopted U.S. Department of Transportation regulations for the movement of hazardous materials originating within the state and passing through the state; State regulations are contained in CCR Title 26. Compliance with these regulations is anticipated to lead to a less-than-significant impact.

The project site is currently used as an orchard. As such, it is considered likely that agricultural chemicals, including pesticides and herbicides, have been used. These chemicals may have accumulated in concentrations that could affect the health of construction workers on the project site. Mitigation described below would ensure that workers would not be exposed to potentially hazardous concentrations of residual agricultural chemicals on project site soils.

**Mitigation Measure No. 5 (Hazards and Hazardous Materials):** Prior to the start of project construction, the developer shall conduct a limited sampling of the surface soil of the project site to determine the presence of residual pesticides, including but not limited to organochlorines. The samples shall be analyzed using California Department of Toxic Substances Control (DTSC) screening levels established for residential projects in Human Health Risk Assessment Note Number 3: DTSC-Modified Screening Levels, June 2020, or by U.S. Environmental Protection Agency Regional Screening Levels if screening levels are not established in HHRA Note Number 3. If no pesticide contamination is found or does not exceed applicable screening levels, then no further action need be taken. If pesticide contamination is identified and found to exceed the applicable screening level, then a Phase II Environmental Site Assessment shall be conducted for the property/properties on which this contamination was identified. The Phase II Environmental Site Assessment shall identify the extent of the contamination and shall recommend measures to remediate soil contamination to

below applicable screening levels. The developer shall implement these actions prior to the start of construction.

c) **No impact.** This project would not emit hazardous emissions or handle hazardous or acutely hazardous materials, substances, or waste within one-quarter mile of an existing or proposed school. There are no existing or proposed active schools within one-quarter mile of the project site. The closest school currently open is Barry Elementary School, approximately five miles northwest of the project site. No impact is anticipated.

d) **No impact.** This project is not located on a site which is included on a list of hazardous materials sites compiled pursuant to California Government Code Section 65962.5. As a result, the project would not create a hazard to the public or the environment; therefore, no impact is anticipated.

e) **No impact.** This project is not located within an airport land use plan or, where such a plan has not been adopted, within two miles of a public airport or public use airport; therefore, this project would not result in a safety hazard or excessive noise for people residing or working in the project area. The nearest public airport is the Yuba County Airport, approximately seven miles northeast of the project site. Due to the project's distance from the nearest airport, no impact is anticipated.

f) **Less than significant impact.** This project would not impact the implementation of, or physically interfere with, an adopted emergency response plan or emergency evacuation plan because the project site has adequate frontage on Garden Highway, which is of sufficient size to not impede any necessary emergency responses or evacuations. The proposed project would not alter Garden Highway and would provide adequate emergency access to the site. The project does not pose a unique or unusual use or activity that would impair the effective and efficient implementation of an adopted emergency response or evacuation plan. A less-than-significant impact is anticipated.

g) **Less than significant impact.** This project would not expose people or structures, either directly or indirectly, to a significant risk of loss, injury, or death involving wildland fires. The General Plan indicates the Sutter Buttes and the "river bottoms," or those areas along the Sacramento, Feather, and Bear Rivers within the levee system, are susceptible to wildfires, since much of the areas inside the levees are left in a natural state, thereby allowing combustible fuels to accumulate over long periods of time. The project site is not located in the Sutter Buttes or "river bottom" areas. Additionally, the project site is not located within or near a fire hazard severity zone. The project site is served by existing fire protection services from the Sutter County Fire Department. Therefore, a significant risk of loss, injury, or death associated with wildland fires as a result of the proposed project is not anticipated, and impacts are considered less than significant.

(County of Sutter, General Plan Technical Background Report. 2008)

(California Department of Toxic Substances Control, Hazardous Waste and Substances Site List - Site Cleanup (Cortese List). 2022)

(Regional Water Quality Control Board, EnviroStor Database. 2022)

(State Water Resources Control Board, Geotracker Database. 2022)

(CAL FIRE, Fire Hazard Severity Zone Viewer. 2022)

## X. HYDROLOGY AND WATER QUALITY

Would the project:	Potentially Significant Impact	Less Than Significant with Mitigation Incorporated	Less Than Significant Impact	No Impact
a) Violate any water quality standards or waste discharge requirements or otherwise substantially degrade surface or ground water quality?			✓	
b) Substantially decrease groundwater supplies or interfere substantially with groundwater recharge such that the project may impede sustainable groundwater management of the basin?			✓	
c) Substantially alter the existing drainage pattern of the site or area, including through the alteration of the course of a stream or river or through the addition of impervious surfaces, in a manner which would:				
i) Result in substantial erosion or siltation on- or off-site;		✓		
ii) Substantially increase the rate or amount of surface runoff in a manner which would result in flooding on- or off-site;		✓		
iii) Create or contribute runoff water which would exceed the capacity of existing or planned stormwater drainage systems or provide substantial additional sources of polluted runoff; or		✓		
iv) Impede or redirect flood flows?			✓	
d) In flood hazard, tsunami, or seiche zones, risk release of pollutants due to project inundation?			✓	
e) Conflict with or obstruct implementation of a water quality control plan or sustainable groundwater management plan?				✓

### Responses:

a) **Less than significant impact.** This project would not violate any water quality standards or waste discharge requirements or otherwise substantially degrade surface or ground water quality. This project proposes the construction and operational use of a 9-acre truck parking yard. Since the project site would exceed one acre, the applicant is required to obtain coverage under the State Construction General Permit, under the NPDES program (Mitigation Measure No. 4). This program requires implementation of erosion control measures designed to avoid significant erosion. The NPDES construction permit requires implementation of a SWPPP that includes storm water BMPs to control runoff, erosion, and sedimentation from the site. This would minimize potential construction impacts on water quality.

A retention basin approximately 1.85 acres in area and 3.5 feet deep would be constructed along the western boundary of the truck parking area to capture the increased storm runoff during project operation. The retention basin would be sloped at a ratio of 4:1. Two outlets

connected to storm drainage pipelines to be installed beneath the parking area would be installed in the retention basin, and riprap would be placed around the outlets.

This project would not violate water quality standards or waste discharge requirements. Compliance with applicable requirements would minimize the project's impact to water quality. No additional mitigation is necessary, and a less-than-significant impact is anticipated.

b) **Less than significant impact.** This project would not substantially decrease groundwater supplies or interfere substantially with groundwater recharge such that the project may impede sustainable groundwater management of the basin. The project is a truck parking yard, and would use minimal water, mainly for proposed landscaping. The project does propose handwashing stations; however, they would be part of the proposed portable trailers, which would be self-contained. The trailers would not be connected to any water wells or other water facilities at the site. It is expected that the project would use less water than the existing land use, which is an orchard.

The proposed truck parking and circulation aisles would be chip sealed and the light duty vehicle parking spaces would be paved with asphalt. Although the project would result in conversion of the site to impervious surfaces, the truck and light vehicle parking area is approximately nine acres and would not substantially impact groundwater recharge in the region. The project design also includes a retention basin that would aid in groundwater recharge.

The project site would be landscaped with trees and shrubs as discussed in the Project Description and as shown on the proposed landscape plan. Landscaping would include an irrigation system with water provided from the well on the site. Under the Commercial and Employment Design Checklist, required landscaping would comply with the current Model Water Efficient Landscaping Ordinance prepared by the California Department of Water Resources, as required by the California Water Conservation in Landscaping Act (Government Code Section 65591 *et seq.*). Landscaping on the project site would not use a substantial amount of groundwater. A less-than-significant impact is anticipated.

c-i, -ii, -iii) **Less than significant with mitigation incorporated.** This project would alter the existing drainage pattern of the site or area, though not in a manner which would result in substantial erosion or siltation on or off site or substantially increase the rate or amount of surface runoff in a manner resulting in flooding on or off-site. This project would also contribute additional runoff water, but it would not exceed the capacity of existing or planned stormwater drainage systems or provide substantial additional sources of polluted runoff or impede or redirect flood flows.

The project proposes to add impervious surfaces in an area that is currently occupied by orchard land. As such, existing drainage patterns would be altered, and additional runoff would be generated. However, the project proposes construction of a 1.85 acre retention basin in the western portion of the site that would collect the additional runoff. Two outlets connected to storm drainage pipelines to be installed beneath the parking area would be installed in the retention basin, and riprap would be placed around the outlets. This would minimize impacts of the release of the additional runoff. Preliminary calculations by the project engineer indicate the retention basin can accommodate the runoff generated by project development, based on a 100-year rainfall event.

The Development Services Engineering Division has reviewed this proposed project and has provided comments regarding the drainage of this project. Based on these comments, the following mitigation measures are recommended to ensure adequate onsite storm drainage facilities:

**Mitigation Measure No. 6 (Hydrology and Water Quality): DRAINAGE STUDY.** Prior to issuance of a grading permit or encroachment permit, the applicant shall obtain approval from the Director of a drainage study that reflects final design conditions for the proposed project per County Standards. The Drainage Study shall be completed and stamped by a Professional Engineer and determined by the County to be comprehensive, accurate, and adequate (SCIS Section 9).

**Mitigation Measure No. 7 (Hydrology and Water Quality): PRIVATE DRAINAGE IMPROVEMENTS.** Prior to commercial use of the site, the applicant shall construct private onsite drainage ditches/basins that provide storm water retention/detention per a County-approved drainage study for this project. Owner shall limit maximum discharge rates, where applicable, to pre-project "existing" conditions for peak 10- and 100-year storms per an approved on-site drainage study for the project. The applicant must obtain a grading permit from the County prior to any grading for storm water retention/detention ditches or basins. The applicant shall provide an as-built drawing of the drainage improvements that is stamped and signed by a licensed Engineer verifying that what was constructed complies with the approved plan for the site.

**Mitigation Measure No. 8 (Hydrology and Water Quality): PRIVATE DRAINAGE FACILITIES MAINTENANCE AGREEMENT.** The property owner shall enter into an agreement with Sutter County committing the property owners and all successors-in-interest to maintain the private drainage facilities (including on-site peak flow attenuation basins) in perpetuity in a manner to preserve storage capacity, drainage patterns, ultimate discharge points and quantities, and water quality treatment controls for stormwater discharges as identified in the drainage study and approved by Sutter County.

**Mitigation Measure No. 9 (Hydrology and Water Quality): GRADING AND CONSTRUCTION.** All impacts to the site must be mitigated in the project area or lands acquired for mitigation by the project. Any Grading or Site Improvements shall be done per an approved plan and in accordance with Sutter County Development Standards. Plans shall be reviewed and approved for construction by the Director of Development Services prior to the start of construction.

In addition, the applicant would be required to prepare a SWPPP as a component of the General Construction Permit for storm water discharges (Mitigation Measure No. 4). This plan would be implemented during the construction phase of the project and would reduce erosion and stormwater pollution.

c-iv) **Less than significant impact.** The project site is located within Flood Zone A according to Flood Insurance Rate Map No. 0603940615E, dated December 1, 2008, issued by the Federal Emergency Management Agency (FEMA). Flood Zone A is one of the Special Flood Hazard Areas that consist of areas subject to inundation by the 1-percent-annual-chance flood event (the "100-year flood"). The applicant would comply with all provisions of the Sutter County Floodplain Management Ordinance and FEMA

regulations, which would be included as a project condition. FEMA does not restrict parking of trucks or vehicles in Special Flood Hazard Areas. However, the applicant would be required to notify tenants who intend to use the site for truck/vehicle parking of the potential flood depths that may cause flood damage to their trucks/vehicles; notification would be implemented as a project condition. With incorporation of these conditions, a less-than-significant impact is anticipated.

d) **Less than significant impact.** Some release of pollutants may occur from trucks caught in a potential flood on the project site, mainly vehicle fluids and oils. It is expected that truck drivers would be provided adequate warning about any potential flooding and would move their trucks away from the project site. Even if that is not the case, trucks themselves are not substantial pollution sources, and any releases of pollutants would likely be diluted by flood waters.

No new building construction is proposed. There is no anticipated impact to this project site resulting from tsunamis and seiches because the land is not located adjacent to or near any water bodies of sufficient size to create such situations. A less-than-significant impact is anticipated.

e) **No Impact.** The project would not conflict with or obstruct implementation of a water quality control plan or sustainable groundwater management plan. There are no currently adopted water quality control plans covering the project site. The County, along with other agencies, has prepared the Sutter Subbasin Groundwater Sustainability Plan that covers most of Sutter County, including the project site. The public comment period on the plan ended in April 2022. The project is not expected to interfere with implementation of the Groundwater Sustainability Plan, particularly since the project would not generate water demand. No impact is anticipated.

(County of Sutter, General Plan Technical Background Report. 2008)

(Federal Emergency Management Agency, Flood Insurance Rate Map. 2008)

(Sutter Subbasin Groundwater Management Coordination Committee, Groundwater Sustainability Plan for the Sutter Subbasin, 2022)

**XI. LAND USE AND PLANNING**

Would the project:	Potentially Significant Impact	Less Than Significant with Mitigation Incorporated	Less Than Significant Impact	No Impact
a) Physically divide an established community?				✓
b) Cause a significant environmental impact due to a conflict with any land use plan, policy, or regulation adopted for the purpose of avoiding or mitigating an environmental effect?			✓	

**Responses:**

a) **No impact.** This project would not physically divide an established community because the project is located outside the Live Oak and Yuba City spheres of influence and the County’s recognized rural communities. This project would not result in a physical barrier that would divide a community, so no impact is anticipated.

b) **Less than significant impact.** This project would not conflict with an applicable land use plan, policy, or regulation adopted for the purpose of avoiding or mitigating an environmental effect, because according to the General Plan the project site is not within a hazardous or biologically sensitive area. The County has not adopted any land use plan, policy, or regulation for the purpose of avoiding or mitigating a specific environmental effect that affects this project. Where necessary, mitigation has been incorporated into the project and no additional mitigation measures are necessary. A less-than-significant impact is anticipated.

(County of Sutter, General Plan 2030. 2011)

(County of Sutter, General Plan Technical Background Report. 2008)

(County of Sutter, Zoning Code. 2022)

**XII. MINERAL RESOURCES**

Would the project:	Potentially Significant Impact	Less Than Significant with Mitigation Incorporated	Less Than Significant Impact	No Impact
a) Result in the loss of availability of a known mineral resource that would be of value to the region and the residents of the state?				✓
b) Result in the loss of availability of a locally important mineral resource recovery site delineated on a local general plan, specific plan, or other land use plan?				✓

**Responses:**

a-b) **No impact.** This project would not result in the loss of availability of a known mineral resource that would be of value to the region and the residents of the state or the loss of availability of a locally important mineral resource recovery site delineated on a local general plan, specific plan, or other land use plan. Neither the General Plan nor the State of California Division of Mines and Geology Special Publication 132 lists the project site as having any substantial mineral deposits of a significant or substantial nature. The project site is not located in the vicinity of any existing surface mines. No impact is anticipated.

(California Department of Conservation, Division of Mines and Geology, Special Report 132: Mineral Land Classification: Portland Cement Concrete-Grade Aggregate in the Yuba City-Marysville Production-Consumption Region. 1988)

(County of Sutter, General Plan Technical Background Report. 2008)

### XIII. NOISE

Would the project result in:	Potentially Significant Impact	Less Than Significant with Mitigation Incorporated	Less Than Significant Impact	No Impact
a) Generation of a substantial temporary or permanent increase in ambient noise levels in the vicinity of the project in excess of standards established in the local general plan or noise ordinance, or applicable standards of other agencies?		✓		
b) Generation of excessive groundborne vibration or groundborne noise levels?			✓	
c) For a project located within the vicinity of a private airstrip or an airport land use plan or, where such a plan has not been adopted, within two miles of a public airport or public use airport, would the project expose people residing or working in the project area to excessive noise levels?			✓	

#### Responses:

a) **Less than significant with mitigation incorporated.** This project would not result in a substantial temporary or permanent increase in ambient noise levels in the project vicinity in excess of standards established in the local general plan or noise ordinances, or applicable standards of other agencies. To determine noise impacts from the proposed project, the project applicant hired Saxelby Acoustics LLC, to prepare an environmental noise assessment. A copy of this assessment is included as Appendix C to this Initial Study. The noise assessment describes characteristics of noise, the existing noise setting, and the regulatory context, and it presents an analysis of potential noise impacts from project construction and operation activities. Impacts were evaluated based on Sutter County General Plan and Zoning Code noise standards, which do not allow exterior noise levels generated by projects to exceed 55 dBA at daytime and 45 dBA at nighttime at residential land uses.

#### Operational Noise

Operations of the proposed project would increase ambient noise levels in the immediate vicinity, primarily through the on-site movement of trucks and trailers. The noise assessment conducted an evaluation of the noise impacts on nearby residences, based on an assumption of six heavy trucks and nine automobiles in a peak hour, in accordance with the traffic impact analysis conducted for the project by KD Anderson & Associates, Inc. As shown on Figure 4 of the noise assessment, the project would produce noise levels of less than 45 dBA at the uninhabitable residence near Garden Highway. Residences farther away would be exposed to lower noise levels. The Sutter County General Plan noise standard for nighttime noise (10:00 p.m. – 7:00 a.m.) is 45 dBA. Therefore, the project would meet this standard, and a less-than significant impact is anticipated.

#### Construction Noise

Construction of the proposed project would require only fine grading and construction of hardscape. No buildings or other structures are proposed. Nevertheless, the proposed

project would result in temporary site construction noise associated with proposed improvements.

Sutter County does not establish quantitative noise limits for construction activities occurring in the County. During project construction, exterior noise levels could affect the nearby existing sensitive receptors in the vicinity. Per Policy N 1.6 of the County's General Plan, all project-related noise-generating construction activities within 1,000 feet of noise-sensitive uses (i.e., residential uses, daycares, schools, convalescent homes, and medical care facilities) are limited to daytime hours between 7:00 a.m. and 6:00 p.m. on weekdays, 8:00 a.m. and 5:00 p.m. on Saturdays, and prohibited on Sundays and holidays unless permission for the latter has been applied for and granted by the County. To ensure compliance with General Plan Policy N 1.6, the following mitigation measure is proposed. Compliance with this mitigation measure would make construction noise impacts less than significant.

**Mitigation Measure No. 10 (Noise):** During construction, the applicant shall ensure that all project related noise-generating construction activities are limited to daytime hours between 7:00 a.m. and 6:00 p.m. on weekdays, 8:00 a.m. and 5:00 p.m. on Saturdays, and are prohibited on Sundays and holidays unless permission for the latter has been applied for and granted by the County.

b) **Less than significant impact.** This project would not result in excessive groundborne vibration or groundborne noise levels. General Plan Policy N 1.7 requires new development to minimize impacts of continuous vibration on adjacent uses during construction. Based on Caltrans standards, a continuous vibration limit of 0.20 in/sec peak particle velocity (PPV) is applied to minimize the potential for cosmetic damage at buildings of normal conventional construction.

Construction equipment or activities that typically generate continuous vibration include, but are not limited to, excavation equipment, impact pile drivers, static compaction equipment, vibratory pile drivers, pile-extraction equipment, and vibratory compaction equipment. Of these equipment types, only excavation equipment would likely be used in the construction of the retention basin. However, such use would be limited and would be at least 100 feet away from the nearest sensitive receptor – the residence to the south. As such, any groundborne vibration associated with excavation would not significantly affect the residence, and in any case would cease after the anticipated 30-day construction period ends.

Groundborne vibration could also be potentially generated by truck traffic, although such vibration is typically not as strong as that generated by construction equipment. The Sutter County Truck Yard Study indicated that trucks traveling at a distance of 50 feet typically generate groundborne vibration velocity levels of approximately 0.006 in/sec PPV, which could reach approximately 0.016 in/sec PPV where trucks pass over discontinuities in the roadway. Given this, vibration levels from truck traffic associated with the project would be below the Caltrans criteria. Therefore, vibration impacts from project operations would be less than significant. Overall, a less-than-significant groundborne vibration impact is anticipated.

c) **Less than significant impact.** This project is not located within the vicinity of a private airstrip, public airport, or public use airport; therefore, it would not result in excessive noise levels for people residing or working in the project area. As noted in the Hazards and

Hazardous Materials section, the nearest public airport is the Yuba County Airport, approximately seven miles northeast of the project site. The closest private airstrip is located approximately 1.5 miles west of the project site, west of the State Highway 99/State Highway 113 interchange. Due to the project's distance from these facilities, a less-than-significant impact is anticipated.

(California Department of Transportation, Transportation and Construction Vibration Guidance Manual. 2013)

(County of Sutter, General Plan 2030. 2011)

(County of Sutter, General Plan Technical Background Report. 2008)

(ESA, Sutter County Truck Yard Study Technical Report. 2021)

(Saxelby Acoustics LLC, Environmental Noise Assessment, Three Truck Parking Facilities on Tudor Road and Garden Highway, Sutter County, California. 2022).

#### XIV. POPULATION AND HOUSING

Would the project:	Potentially Significant Impact	Less Than Significant with Mitigation Incorporated	Less Than Significant Impact	No Impact
a) Induce substantial unplanned population growth in an area, either directly (for example, by proposing new homes and businesses) or indirectly (for example, through extension of roads or other infrastructure)?			✓	
b) Displace substantial numbers of existing people or housing, necessitating the construction of replacement housing elsewhere?				✓

#### Responses:

a) **Less than significant impact.** This project would not induce substantial unplanned population growth in an area, directly or indirectly. No residential use is proposed as part of the project and there would be no direct population growth. The truck yard would be attended by one security staff member. Therefore, the project would not induce substantial indirect population growth. The amount of population growth in the area would be negligible and a less-than-significant impact is anticipated.

b) **No impact.** This project would not displace substantial numbers of people or existing housing, necessitating the construction of replacement housing elsewhere. One single-family residence exists on the project site, which is currently unoccupied due to fire damage; however, it is proposed to be repaired. The proposed project would not expand beyond the property boundaries; therefore, it would not displace any housing or people outside these boundaries. No impact is anticipated.

(County of Sutter, General Plan Technical Background Report. 2008)

**XV. PUBLIC SERVICES**

a) Would the project result in substantial adverse physical impacts associated with the provision of new or physically altered governmental facilities, need for new or physically altered governmental facilities, the construction of which could cause significant environmental impacts, in order to maintain acceptable service ratios, response times or other performance objectives for any of the public services:	Potentially Significant Impact	Less Than Significant with Mitigation Incorporated	Less Than Significant Impact	No Impact
i) Fire protection?			✓	
ii) Police protection?			✓	
iii) Schools?				✓
iv) Parks?				✓
v) Other public facilities?				✓

**Responses:**

a-i) **Less than significant impact.** Fire protection services for the project vicinity are provided by Sutter County Fire Services. The project site is located in County Service Area F. The nearest fire station is approximately five miles north of the project site - the Oswald-Tudor station (Station 8) on 1280 Barry Road, at the southeast corner of State Highway 99 and Barry Road. The project would not affect fire service response time. Existing County roads would provide adequate transportation routes to reach the project site in the event of a fire. The project is a truck yard that would provide parking spaces only; no new buildings or an increase in population would occur. The project would provide adequate emergency access for firefighting vehicles. Sutter County Fire Services had no comments on this project. Based on this information, the construction of new fire facilities would not be required to provide adequate service to this project. A less-than-significant impact is anticipated.

a-ii) **Less than significant impact.** This project would not have a significant impact on police protection. Law enforcement services for unincorporated portions of Sutter County are provided by the Sutter County Sheriff’s Department, and traffic investigation services are provided by the California Highway Patrol. Response time would not be affected by the proposed project because the project would not result in an increase in population. Existing State Highways or County roads would provide adequate transportation routes to reach the project site in the event of an emergency. Traffic impacts are discussed in the Transportation section of this Initial Study. The construction of new sheriff facilities would not be required to provide adequate service to this project. A less-than-significant impact is anticipated.

a-iii) **No impact.** This project would not have a significant impact on schools because this project would not generate additional demand for school services. No new buildings or residences are proposed with this project. There would not be any new students. No impact is anticipated.

a-iv) **No impact.** This project would not have a significant impact upon parks because it would not generate a need for additional park land or create an additional impact upon

existing parks in the region. This project would not result in any new residences which require park services; therefore, this project would not have a significant impact on countywide parks. No impact is anticipated.

a-v) **No impact.** This project is not anticipated to impact other public facilities because the project would not result in the need for additional or new public facilities. No new buildings or residences are proposed with this project that would generate a demand for other public services. No impact is anticipated.

(County of Sutter, Zoning Code. 2022)

(County of Sutter, General Plan Technical Background Report. 2008)

**XVI. RECREATION**

	Potentially Significant Impact	Less Than Significant with Mitigation Incorporated	Less Than Significant Impact	No Impact
a) Would the project increase the use of existing neighborhood and regional parks or other recreational facilities such that substantial physical deterioration of the facility would occur or be accelerated?				✓
b) Does the project include recreational facilities or require the construction or expansion of recreational facilities which might have an adverse physical effect on the environment?				✓

**Responses:**

a-b) **No impact.** This project would not increase the use of existing neighborhood and regional parks or other recreational facilities such that substantial physical deterioration of the facility would occur or be accelerated. The project would not include recreational facilities or require the construction or expansion of recreational facilities which might have an adverse physical effect on the environment. This project would not result in residential development, which would generate demand for recreational facilities such that new or expanded facilities would be required. There are no existing neighborhood or regional parks in the project vicinity that would be potentially affected. No impact is anticipated.

(County of Sutter, General Plan Technical Background Report. 2008)

## XVII. TRANSPORTATION

Would the project:	Potentially Significant Impact	Less Than Significant with Mitigation Incorporated	Less Than Significant Impact	No Impact
a) Conflict with a program, plan, ordinance or policy addressing the circulation system, including transit, roadway, bicycle and pedestrian facilities?		✓		
b) Conflict or be inconsistent with CEQA Guidelines Section 15064.3, subdivision (b)?			✓	
c) Substantially increase hazards to a geometric design feature (e.g., sharp curves or dangerous intersections) or incompatible uses (e.g., farm equipment)?			✓	
d) Result in inadequate emergency access?			✓	

### Responses:

a) **Less than significant with mitigation incorporated.** This project would not conflict with a program, plan, ordinance, or policy addressing the circulation system, including transit, roadway, bicycle, and pedestrian facilities. This property is in a rural area approximately six miles south of the southernmost incorporated limits of Yuba City and its sphere of influence. The project area is not served by mass transit or bicycle paths, and no sidewalks have been installed. Given the rural nature of the area, personal vehicles would be the most likely form of transportation.

The Sutter County General Plan establishes the County's Level of Service (LOS) policy for County roads. LOS is a qualitative measure of traffic flow ranging from A to F, with A representing best conditions. Policy M 2.5 is to develop and manage the County roadway segments and intersections to maintain LOS D or better during peak hours, and LOS C or better at all other times. The County LOS standards apply to all County roadway segments and intersections, unless otherwise addressed in an adopted specific plan or community plan.

A transportation impact analysis for this and two other proposed truck parking facilities, one of which does not have an active or pending application, was prepared by KD Anderson & Associates, Inc. A copy of this analysis is included as Appendix D to this Initial Study. The traffic analysis documents the existing traffic setting, applicable regulations, project travel characteristics, project operational analysis under proposed project and cumulative conditions, and project impacts under CEQA. It also evaluated project impacts on other modes of transportation, such as transit and bicycling.

For this project, the traffic analysis estimated a total of 154 daily truck trips and 231 daily automobile trips. Caltrans has approved a STAA Terminal route extension south on Garden Highway from the current Tudor Road terminus to beyond the project access. The designation does not extend to Wilson Road. Therefore, all truck traffic has been assumed to use Tudor Road to the State Highway 99 interchange.

Some of the key findings as listed in the traffic analysis are presented below, which apply to this section:

- The addition of project trips would not change the current LOS on any of the

roadways studied: Garden Highway from Wilson Avenue to Tudor Road, and Tudor Road from Garden Highway to State Highway 99. Both roadways would continue to operate at the current LOS B, which satisfies the General Plan's minimum requirement of LOS D.

- The addition of project trips would not change the current LOS at the Tudor Road/Garden Highway intersection north of the project site. The intersection would continue to operate at the current LOS A, which satisfies the General Plan's minimum requirement.
- Peak hour traffic volumes at the Tudor Road/Garden Highway intersection were reviewed to determine whether the addition of project traffic may cause volumes to reach a level that satisfied traffic signal warrants. The traffic analysis concluded that anticipated volumes fall below those required to satisfy applicable warrants; therefore, no traffic signals would be required at this intersection.

In summary, the traffic analysis concluded that the project would not conflict with applicable General Plan policies regarding transportation. No mitigation measures were identified. The analysis also concluded there would be no impacts on bicycle, pedestrian, or mass transit facilities.

The project application was circulated to Caltrans for review and comment, since project traffic proposes to use State Highway 99. Caltrans had no comments regarding the proposed project.

The Development Services Engineering Division reviewed this project, including the traffic study, and determined that no additional land dedications are required. They have provided comments regarding transportation of this project. Based on these comments, the following mitigation measure is recommended:

**Mitigation Measure No. 11 (Transportation):** Prior to commercial use of the site and prior to use of this facility by Surface Transportation Assistance Act (STAA) trucks, the applicant must show that the site has access to an established STAA route with the proper signage in place. In addition, the applicant must submit and obtain approval of a STAA route access plan which shows the STAA route to be used by the facility.

Based on the findings of the traffic study, and with the proposed mitigation measure incorporated into the project, a less-than-significant impact is anticipated.

b) **Less than significant impact.** This project would not conflict or be inconsistent with CEQA Guidelines §15064.3, subdivision (b). This section of CEQA states that vehicle miles traveled (VMT) is the most appropriate measure of transportation impacts. VMT refers to the amount and distance of automobile travel attributable to a project. The Governor's Office of Planning and Research (OPR) Technical Advisory for VMT assessment clarifies that "the term 'automobile' refers to on-road passenger vehicles, specifically cars and light trucks." It does not include heavy-duty trucks, although VMT for these vehicles could be included for modeling convenience and ease of calculation.

This section also states VMT exceeding an applicable threshold of significance may indicate a significant impact. The County has not adopted a threshold of significance for VMT. Sutter County has not yet adopted guidelines or policies for dealing with VMT.

Therefore, the VMT impact assessment in the project traffic analysis uses the guidance in OPR's Technical Advisory.

Screening criteria can be used to quickly identify whether sufficient evidence exists to presume a project would have a less-than-significant VMT impact without conducting a detailed study. Projects meeting at least one of the criteria below can be presumed to have a less-than-significant VMT impact, absent substantial evidence that the project would lead to a significant impact.

- Small projects
- Projects near transit stations
- Affordable residential development
- Local-serving retail
- Projects in low VMT-generating area

A “small project”, as defined in the Technical Advisory, is a project that generates less than 110 automobile trips daily. As noted in a), the project is estimated to generate 231 automobile trips daily, so the project would not be considered a small project. The project does not meet the next three screening criteria. The project is in unincorporated Sutter County, which is considered a low VMT-generating area. However, the commercial areas in the general vicinity all exhibit high “per job” VMT that exceed both the SACOG regional average and the average for unincorporated Sutter County. As a result, the project’s regional VMT impact cannot be presumed to be less than significant simply based on location, and additional assessment is required.

The traffic analysis assessed the project’s VMT impacts with regards to the actual characteristics of the activities that generate automobile VMT. Automobile trips would be generated as truck drivers move to and from the site and their homes, either using their personal vehicle or being dropped off. Because the project’s spaces would be used by truckers who would be inclined to park near their residence, it is possible to estimate project VMT based on the forecasted daily trip generation and the average distance to area residences based on the trip distribution assumptions made earlier. A weighted average distance from the project area to residences in the assumed trip distribution pattern was identified for the project and applied to the daily trip generation forecasts. In turn, the VMT forecasts were divided by the number of jobs (i.e., spaces) to develop “per-job” VMT. The per-job VMT value was then compared to the average VMT rate that would meet a 15% VMT reduction goals for unincorporated Sutter County.

For this project, a per-job VMT of 19.1 was calculated. For unincorporated Sutter County, 85% of the average per-job VMT for unincorporated Sutter County is 23.3. Because the project VMT is below the per-job VMT for Sutter County minus 15%, the project would be below the VMT threshold of significance described in the OPR Technical Advisory. Project VMT impacts would be less than significant.

c-d) **Less than significant impact.** This project would not substantially increase hazards due to a geometric design feature (e.g., sharp curves or dangerous intersections) or incompatible uses (e.g., farm equipment) nor would it result in inadequate emergency access. The project site has adequate frontage on Garden Highway, a County-maintained road. As discussed in the Hazards and Hazardous Material section, Garden Highway is of sufficient size to not impede any necessary emergency responses or evacuations.

The traffic analysis noted that alignment of Tudor Road and Garden Highway in this area is level and straight. As a result, the view measured 15 feet from the edge of the travel way would satisfy Caltrans Minimum Sight Distance (Table 201.1 - 500 feet at 55 mph) and Corner Sight Distance (Table 405.1a - 925 feet at 55 mph) requirements in both directions.

The proposed access to the project site features large radius (65-foot) corner returns. The site plan provided by the civil engineer illustrates that the layout would allow trucks to access the site in all directions without interfering with a vehicle headed in the other direction. Functionally, the large radius corners would allow trucks to enter the site without slowing to a crawl or stopping to wait for a conflicting vehicle. The driveway is about 900 feet from the all-way stop intersection at Tudor Road. Based on typical truck acceleration and deceleration rates, a truck would exit the intersection and accelerate to about 35 mph before beginning to slow to enter the site when turning right.

The project is expected to create eight inbound truck trips during the weekday p.m. peak hour, or one every 7.5 minutes. While a following motorist may occasionally be delayed by a truck slowing to turn right, because background traffic volumes on Garden Highway are low, a separate deceleration treatment does not appear justified. Because truck traffic is most likely to exit by turning left due to the absence of STAA designation further to the south, an acceleration lane is not justified.

The impacts of a project to safety on Caltrans facilities remains an issue of significance. Under current practice, safety impacts on state facilities are typically considered within the context of queuing on off-ramps and in turn lanes at intersections, truck turning requirements and the need for alternative traffic control devices. Queuing that spills over from a turn lane or extends along an off-ramp to the mainline freeway could represent significant safety issues. Intersections where truck paths leave the pavement or encroach into opposing lanes are a safety issue. Operation of an intersection with inappropriate traffic control devices would also represent a potential safety issue.

The traffic analysis noted that the project could add a small amount of automobile and truck traffic through the State Highway 99/State Highway 113 interchange. However, because current traffic volumes are low, a small increase would not result in any appreciable increase in queuing that might cause a safety issue as it relates to mainline State Highway 99. While the ramp terminal intersections are currently stop-controlled, the addition of project traffic would not result in the need for signalization at these low volume levels. The project also would add truck traffic turning at the intersections at the interchange. However, the interchange is already handling heavy trucks that are permitted under STAA. STAA trucks are not permitted at the State Highway 99/Wilson Road intersection, and the STAA designation would only link Tudor Road with the project site. Thus, the project does not result in a situation where truck turns would cause a safety impact.

Overall, the project would not increase safety hazards on roadways and intersections in the vicinity, and no mitigation would be required. A less-than-significant impact is anticipated.

(County of Sutter, General Plan Technical Background Report. 2008)

(County of Sutter, General Plan 2030. 2011)

(KD Anderson & Associates, Inc., CEQA Transportation Impact Analysis and Traffic Operational Assessment for Three Truck Parking Facilities on Tudor Road and Garden Highway, Sutter County, California. 2022)

**XVIII. TRIBAL CULTURAL RESOURCES**

a) Would the project cause a substantial adverse change in the significance of a tribal cultural resource, defined in Public Resources Code Section 21074 as either a site, feature, place, cultural landscape that is geographically defined in terms of the size and scope of the landscape, sacred place, or object with cultural value to a California Native American tribe, and that is:	Potentially Significant Impact	Less Than Significant with Mitigation Incorporated	Less Than Significant Impact	No Impact
i) Listed or eligible for listing in the California Register of Historical Resources, or in a local register of historical resources as defined in Public Resources Code Section 5020.1(k), or		✓		
ii) A resource determined by the lead agency, in its discretion and supported by substantial evidence, to be significant pursuant to criteria set forth in subdivision (c) of Public Resources Code Section 5024.1? In applying the criteria set forth in subdivision (c) of Public Resources Code Section 5024.1, the lead agency shall consider the significance of the resource to a California Native American tribe.		✓		

**Responses:**

a) **Less than significant with mitigation incorporated.** In September of 2014, the California Legislature passed Assembly Bill (AB) 52, which added provisions to the Public Resources Code regarding the evaluation of impacts on tribal cultural resources under CEQA, and consultation requirements with California Native American tribes.

On May 5, 2022, the County sent a notice to the following seven local tribes inviting comments on the project:

- Mechoopda Indian Tribe of Chico Rancheria
- Mooretown Rancheria of Maidu Indians
- United Auburn Indian Community of the Auburn Rancheria (UAIC)
- Strawberry Valley Rancheria
- Enterprise Rancheria of Maidu Indians
- Lone Band of Miwok Indians
- Wilton Rancheria

The notification was reissued September 30, 2022 when it was discovered that some tribes had not received the first notification. Of these seven, responses were received from three tribes. The Mooretown Rancheria and the Enterprise Rancheria both stated that they had no record of any cultural resources in the area, though they reserved the right to be notified of any post-review/inadvertent discoveries. The UAIC requested consultation on the project per AB 52, as the tribe identified sacred lands that included burials overlapping

a portion of the parcel. They have recommended that they conduct a tribal survey to identify the presence of any surficial tribal cultural resource or cultural soils. A paid tribal monitor will need to be present once the orchard trees have been removed, but prior to any grading, to ensure there are no burials present. The following mitigation measure would be implemented, based on the UAIC recommendations.

**Mitigation Measure No. 12 (Tribal Cultural Resources):** After the removal of the orchard trees, but prior to any grading, earthwork, or other soil disturbing activities, the applicant shall contact the Development Services Department so that a United Auburn Indian Community (UAIC) Tribal Representative or Tribal Monitor can be invited to inspect the project site. During this inspection, a UAIC Tribal Representative or Tribal Monitor may provide an on-site meeting for construction personnel information on TCRs and worker awareness brochures.

On a proposed truck yard project site approximately 625 feet to the south, the UAIC recommended actions be taken to protect potential tribal cultural resources at that location. Since the UAIC indicated the potential presence of a tribal cultural resource on this project site, the following mitigation measure shall be implemented, based on the UAIC recommendations.

**Mitigation Measure No. 13 (Tribal Cultural Resources):** If any suspected tribal cultural resources (TCRs) are discovered during project ground disturbing construction activities, all work shall cease within 100 feet of the find, or an agreed upon distance based on the project area and nature of the find. A Tribal Representative from a California Native American tribe that is traditionally and culturally affiliated with a geographic area shall be immediately notified and shall determine if the find is a TCR (PRC §21074). The Tribal Representative shall make recommendations for further evaluation and treatment as necessary.

When avoidance is infeasible, preservation in place is the preferred option for mitigation of TCRs under CEQA, and every effort shall be made to preserve the resources in place, including through project redesign, if feasible. Culturally appropriate treatment may be, but is not limited to, processing materials for reburial, minimizing handling of cultural objects, leaving objects in place within the landscape, or returning objects to a location within the project area where they would not be subject to future impacts. Permanent curation of TCRs would not take place unless approved in writing by the California Native American Tribe that is traditionally and culturally affiliated with the project area.

The contractor shall implement any measures deemed by the CEQA lead agency to be necessary and feasible to preserve in place, avoid, or minimize impacts to the resource, including, but not limited to, facilitating the appropriate tribal treatment of the find, as necessary. Treatment that preserves or restores the cultural character and integrity of a TCR may include tribal monitoring, culturally appropriate recovery of cultural objects, and reburial of cultural objects or cultural soil. Work at the discovery location shall not resume until all necessary investigation and evaluation of the discovery under the requirements of the CEQA, including AB 52, have been satisfied.

Compliance with these mitigation measures would reduce project impacts on tribal cultural resources to a level that would be less than significant.

## XIX. UTILITIES AND SERVICE SYSTEMS

Would the project:	Potentially Significant Impact	Less Than Significant with Mitigation Incorporated	Less Than Significant Impact	No Impact
a) Require or result in the relocation or construction of new or expanded water, wastewater treatment or storm water drainage, electric power, natural gas, or telecommunications facilities, the construction or relocation of which could cause significant environmental effects?			✓	
b) Have sufficient water supplies available to serve the project and reasonably foreseeable future development during normal, dry, and multiple dry years?			✓	
c) Result in a determination by the wastewater treatment provider that serves or may serve the project that it has adequate capacity to serve the project's projected demand in addition to the provider's existing commitments?				✓
d) Generate solid waste in excess of state or local standards, or in excess of the capacity of local infrastructure, or otherwise impair the attainment of solid waste reduction goals?			✓	
e) Comply with federal, state and local management and reduction statutes and regulations related to solid waste?			✓	

### Responses:

a) **Less than significant impact.** This project would not require or result in the relocation or construction of new or expanded water, wastewater treatment, or storm water drainage, electric power, natural gas, or telecommunications facilities, the construction or relocation of which could cause significant environmental effects. This project would require no new water service, wastewater treatment service, natural gas, or telecommunications facilities. Electric power needs would be satisfied by tying into existing utilities provided at the site. In a comment letter, the Pacific Gas and Electric Company (PG&E) stated that the proposed improvements do not appear to directly interfere with existing PG&E facilities or impact easement rights.

Private drainage improvements are proposed for the site, as discussed previously in the Hydrology and Water Quality section. The environmental impacts of the construction of these onsite drainage improvements are addressed in this environmental document. The applicant is required to obtain coverage under the State Construction General Permit, which requires implementation of a SWPPP that includes BMPs to control runoff, erosion, and sedimentation from the site. A retention basin approximately 1.85 acres in area and 3.5 feet deep would be constructed along the western boundary of the truck parking area to capture the increased storm runoff during project operation. Two outlets connected to storm drainage pipelines to be installed beneath the parking area would be installed in the retention basin, and riprap would be placed around the outlets. No additional mitigation is needed, and a less-than-significant impact is anticipated.

b) **Less than significant impact.** This project would not place a significant demand on water supplies. As stated in the Hydrology and Water Quality section, this project is not anticipated to generate any water demand other than for landscaping and for handwashing stations on self-contained portable trailers. Moreover, as noted in the Hydrology and Water Quality section, water demand from the project is expected to be less than the demand from the current land use, which is an orchard. Water would be provided by the existing well on the site. No wells or other water facilities would be installed. A less-than-significant impact is anticipated.

c) **No impact.** This project would not result in a determination by a wastewater treatment provider which serves or may serve the project that it has adequate capacity to serve the project's projected demand in addition to the provider's existing commitments. This project is not located in an area that is served by a wastewater treatment provider. As noted in the Geology and Soils section, the project proposes to use portable toilets. These toilets would be pumped by a septic pumper registered with Sutter County. Therefore, no demands would be placed on a local sanitary sewer system, and no impact is anticipated.

d-e) **Less than significant impact.** This project would have a less than significant impact on solid waste. Solid waste from this project would be disposed of through the local waste disposal company in a sanitary landfill in Yuba County which has sufficient capacity to serve this project. Disposal of project solid waste into that facility would comply with all federal, state, and local statutes and regulations related to solid waste. As a result, a less-than-significant impact is anticipated.

(County of Sutter, General Plan Technical Background Report. 2008)

**XX. WILDFIRE**

If located in or near state responsibility areas or lands classified as Very High Fire Hazard Severity Zones, would the project:	Potentially Significant Impact	Less Than Significant with Mitigation Incorporated	Less Than Significant Impact	No Impact
a) Substantially impair an adopted emergency response plan or emergency evacuation plan?				✓
b) Due to slope, prevailing winds, and other factors, exacerbate wildfire risks, and thereby expose project occupants to pollutant concentrations from a wildfire or the uncontrolled spread of a wildfire?				✓
c) Require the installation or maintenance of associated infrastructure (such as roads, fuel breaks, emergency water sources, power lines or other utilities) that may exacerbate fire risk or that may result in temporary or ongoing impacts to the environment?				✓
d) Expose people or structures to significant risks, including downslope or downstream flooding or landslides, as a result of runoff, post-fire slope instability, or drainage changes?				✓

**Responses:**

a-d) **No impact.** The subject property is not located in or near state responsibility areas or lands classified as very high fire hazard severity zones; therefore, no impacts are anticipated.

(CAL FIRE, Fire Hazard Severity Zone Viewer. 2022)

**XXI. MANDATORY FINDINGS OF SIGNIFICANCE**

	Potentially Significant Impact	Less Than Significant with Mitigation Incorporated	Less Than Significant Impact	No Impact
a) Does the project have the potential to substantially degrade the quality of the environment, substantially reduce the habitat of a fish or wildlife species, cause a fish or wildlife population to drop below self-sustaining levels, threaten to eliminate a plant or animal community, substantially reduce the number or restrict the range of a rare or endangered plant or animal or eliminate important examples of the major periods of California history or prehistory?		✓		
b) Does the project have impacts that are individually limited, but cumulatively considerable? "Cumulatively considerable" means that the incremental effects of a project are considerable when viewed in connection with the effects of past projects, the effects of other current projects, and the effects of probable future projects)?		✓		
c) Does the project have environmental effects which would cause substantial adverse effects on human beings, either directly or indirectly?			✓	

**Responses:**

a) **Less than significant with mitigation incorporated.** No environmental effects were identified in the initial study which indicate this project would have the ability to degrade the quality of the environment, substantially reduce the habitat of a fish or wildlife species, cause a fish or wildlife population to drop below self-sustaining levels, threaten to eliminate a plant or animal community, reduce the number or restrict the range of a rare or endangered plant or animal or eliminate important examples of the major periods of California history or prehistory. Mitigation Measures Nos. 2 and 3, proposed in the Cultural Resources section, would protect possible disturbance of archaeological resources and human remains, respectively, should they be encountered. Mitigation Measures Nos. 12 and 13, proposed in the Tribal Cultural Resources section, would protect any tribal cultural resources encountered.

b) **Less than significant with mitigation incorporated.** The project site is in an area where truck yards have been proposed. The proposed project is one of three truck yards proposed in the area: two along Garden Highway and one on Tudor Road, all east of State Highway 99. The Tudor Road site currently does not have an active or pending application.

However, the cumulative impact analysis would focus on the proposed project and the other two truck yards, including the one for which no application is pending.

A study analyzing the potential cumulative impacts of truck yard development, primarily along the State Highway 99 corridor south of Yuba City, was conducted for the County by ESA. The study identified six areas of potential cumulative environmental impacts: air quality, health risk from TAC emissions, hydrology, lighting, noise, and traffic. The potential cumulative impacts of the proposed project on each of these issues is presented below.

Air Quality: Data from the air quality analysis for the proposed project indicate that its operational emissions would not exceed the established FRAQMD thresholds of significance for criteria pollutants (see Section III, Air Quality). According to the project traffic analysis, the other site on Garden Highway would have approximately half the daily traffic generated by the proposed project. Assuming that pollutant emissions are directly proportional to daily traffic, the operational emissions of the other Garden Highway site would still be well below FRAQMD significance thresholds. The Tudor site would generate far less daily traffic than the Garden Highway sites, and operational emissions from this site would likewise be below FRAQMD significance thresholds.

Future attainment of federal and State ambient air quality standards is a function of successful implementation of the applicable attainment plans. Consequently, the application of significance thresholds for criteria pollutants is relevant to the determination of whether a project's individual emissions would have a cumulatively significant impact on air quality. Since none of the proposed truck yards are anticipated to exceed the FRAQMD significance thresholds, they would be considered to have no cumulatively considerable impacts regarding attainment of air quality plans. It should be noted that all truck engines on the site for this project and for the project to the south (Site #3) are proposed to be 2014 or newer, which would further reduce cumulative emissions.

Health Risk: Exposure of sensitive receptors to potential health risks are a localized impact and typically are not considered cumulative in character. The air quality analysis for the proposed project concluded that there would be no significant health risks from operations.

Hydrology: As with health risks, hydrologic impacts are localized in character and typically do not have cumulative effects. As described in the Hydrology and Water Quality section, the proposed project would not have significant drainage and runoff impacts with implementation of Mitigation Measures Nos. 6 through 9. The mitigation measures for the proposed project would likely apply to the other sites as all sites over one-acre are required to prepare a SWPPP and comply with the NPDES General Permit.

Lighting: Lighting impacts are localized in character and typically do not have cumulative effects. All projects would be required to conform to the exterior lighting requirements of the County's Zoning Code that require down shielding and other measures to reduce light spillover.

Noise: In rural areas, noise impacts generally are localized in character and typically do not have cumulative effects, unless noise sources are located closely. The noise analysis conducted for the proposed project also considered the other two sites. The proposed project would not generate noise at a level that could exceed County standards for nearby residences and noise generated at the other two sites would also not exceed such County

standards. Mitigation Measure No. 10 would be applied to the proposed project, as described in Section XIII, Noise, to reduce noise impacts.

Traffic: As noted in the Transportation section, a traffic analysis was conducted for the proposed project. The analysis included an assessment of project traffic impacts under cumulative conditions. “Cumulative conditions” were defined from two perspectives:

- Year 2040 conditions based on SACOG SacSim regional travel demand forecasting model results, and
- Year 2040 traffic volume forecasts from the Sutter County General Plan EIR.

The relative cumulative traffic effects of the proposed project and two other proposed projects in the vicinity (one of which has no application submitted or pending) were assessed within the context of future traffic volumes and General Plan LOS thresholds. All study area roadways (Garden Highway and Tudor Road) are forecast to continue to operate within the General Plan’s LOS C limit with and without the project.

The traffic analysis conducted a VMT analysis for the proposed project and the two other truck yard projects in the vicinity. None of these projects were found to exceed the VMT significance threshold described in the OPR Technical Advisory. Since none of the projects would exceed this VMT threshold, the project is not considered to have a cumulatively considerable impact on VMT.

Based on the information provided above, and with the implementation of Mitigation Measure No. 11, the project’s contribution to cumulative impacts is anticipated to be less than significant.

c) **Less than significant impact.** No environmental effects which would cause substantial adverse effects on human beings either directly or indirectly were identified in the initial study.

(ESA, Sutter County Truck Yard Study Technical Report. 2021)

(KD Anderson and Associates, Inc., CEQA Transportation Impact Analysis and Traffic Operational Assessment for Three Truck Parking Facilities on Tudor Road and Garden Highway, Sutter County, California. 2022)

## **Bibliography**

CAL FIRE. 2022. *Fire Hazard Severity Zone Viewer*.

California Department of Conservation. 2018. *Farmland Mapping and Monitoring Program*

California Department of Conservation, Division of Mines and Geology. 1988. *Special Report 132: Mineral Land Classification: Portland Cement Concrete-Grade Aggregate in the Yuba City-Marysville Production-Consumption Region*

California Department of Toxic Substances Control, 2022. *Hazardous Waste and Substances Site List - Site Cleanup (Cortese List)*

California Department of Transportation. 2013. *Transportation and Construction Vibration Guidance Manual*.

California Department of Transportation. 2022. *California State Scenic Highways*

County of Sutter. 2008. *General Plan Technical Background Report*

County of Sutter. 2008. *General Plan Draft Environmental Impact Report*

County of Sutter. 2011. *General Plan 2030*

County of Sutter. 2011. *General Plan 2030 Climate Action Plan*

County of Sutter. 2016. *Greenhouse Gas Pre-Screening Measures for Sutter County*

County of Sutter. 2022. *Zoning Code*

Environmental Permitting Specialists. 2022. *Draft Analysis of Impacts to Air Quality and Greenhouse Gas from Proposed Truck Yard, Yuba City, California*.

ESA. 2021. *Sutter County Truck Yard Study Technical Report*

Feather River Air Quality Management District (FRAQMD), 2010. *Indirect Source Review Guidelines*

Federal Emergency Management Agency. 2008. *Flood Insurance Rate Map*

KD Anderson & Associates, Inc. 2022. *CEQA Transportation Impact Analysis and Traffic Operational Assessment for Three Truck Parking Facilities on Tudor Road and Garden Highway, Sutter County, California*

National Park Service. 2021. *National Register of Historic Places*

Regional Water Quality Control Board. 2022. *EnviroStor Database*.

Saxelby Acoustics LLC. 2022. *Environmental Noise Assessment, Three Truck Parking Facilities on Tudor Road and Garden Highway, Sutter County, California*

State Water Resources Control Board. 2022. *Geotracker Database*.

U.S. Department of Agriculture, Natural Resources Conservation Service. 2022. *Custom Soil Survey, Sutter County, 8645 Garden Highway*

U.S. Department of Agriculture, Soil Conservation Service. 1988. *Sutter County Soil Survey*

U.S. Fish and Wildlife Service. 2022. *Critical Habitat Mapper*

U.S. Fish and Wildlife Service. 2022. *National Wetlands Inventory*

## MITIGATION MONITORING PROGRAM

Mitigation Measure	Timing	Monitoring Agency
<p><b>Mitigation Measure No. 1 (Air Quality):</b> IMPLEMENT FEATHER RIVER AIR QUALITY MANAGEMENT DISTRICT (FRAQMD) STANDARD MITIGATION MEASURES. The project applicant shall implement the following FRAQMD-recommended Standard Mitigation Measures for projects that do not exceed construction or operational thresholds of significance.</p> <ul style="list-style-type: none"> <li>● Implement the Fugitive Dust Control Plan prior to any on-site grading, landscaping, or construction activities. The applicant shall submit the fugitive dust control plan to the FRAQMD for review and approval. A copy of the approved plan shall be submitted to the Development Services Department.</li> <li>● Construction equipment exhaust emissions shall not exceed FRAQMD Regulation III, Rule 3.0, Visible Emissions limitations (40 percent opacity or Ringlemann 2.0).</li> <li>● The contractor shall be responsible to ensure that all construction equipment is properly tuned and maintained prior to and for the duration of onsite operation.</li> <li>● Limit idling time to 5 minutes – saves fuel and reduces emissions in accordance with 13 California Code of Regulations (CCR) Chapter 10 Section 2485 and 13 CCR Chapter 9 Article 4.8 Section 2449.</li> <li>● Utilize existing power sources or clean fuel generators rather than temporary power generators.</li> <li>● Develop traffic plans to minimize traffic flow interference from construction activities. The plan may include advance public notice of routing, use of public transportation, and satellite parking areas with a shuttle service. Schedule operations affecting traffic for off-peak hours. Minimize obstruction of through-traffic lanes. Provide a flag</li> </ul>	<p>Prior to construction activities/Ongoing</p>	<p>FRAQMD/ Development Services</p>

Mitigation Measure	Timing	Monitoring Agency
<p>person to guide traffic properly and ensure safety at construction sites.</p> <ul style="list-style-type: none"> <li>• Portable engines and portable engine-driven equipment units used at the project work site, with the exception of on-road and off-road motor vehicles, may require CARB Portable Equipment Registration with the State or a local district permit. The owner/operator shall be responsible for arranging appropriate consultation with CARB or FRAQMD to determine registration and permitting requirements prior to equipment operation at the site.</li> </ul>		
<p><b>Mitigation Measure No. 2 (Cultural Resources):</b> If archaeological resources are discovered on the project site, potential ground disturbing activities within 100 feet of the find shall be halted immediately and the Development Services Department shall be notified. A qualified archaeologist shall examine the find and evaluate its significance. The archaeologist shall recommend measures needed to reduce effects on the cultural resource in a written report to the County. The County shall be responsible for implementing the report recommendations.</p>	<p>During construction activities</p>	<p>Construction personnel</p>
<p><b>Mitigation Measure No. 3 (Cultural Resources):</b> If human remains are discovered on the site potentially ground disturbing activities within 100 feet of the remains shall be halted immediately, and the project applicant shall notify the Sutter County Coroner and Native American Heritage Commission (NAHC) immediately, according to Public Resources Code §5097.98 and Section 7050.5 of California's Health and Safety Code. If the remains are determined by the NAHC to be Native American, the guidelines of the NAHC shall be adhered to in the treatment and disposition of the remains. The project applicant shall also retain a professional archaeologist with Native American burial experience to conduct a field investigation of the specific site and consult with the Most Likely Descendant, if any, identified by the NAHC. Following the coroner's and NAHC's findings, the archaeologist, and the NAHC-designated Most Likely Descendant shall determine the ultimate treatment and disposition of the remains and take appropriate steps to ensure that additional human</p>	<p>During construction activities</p>	<p>Construction personnel</p>

Mitigation Measure	Timing	Monitoring Agency
interments are not disturbed. The responsibilities for acting upon notification of a discovery of Native American human remains are identified in Public Resources Code Section 5097.94.		
<p><b>Mitigation Measure No. 4 (Geology and Soils):</b>  <b>STORM WATER QUALITY PROTECTION – DURING CONSTRUCTION.</b></p> <p>SWPPP - Prior to the start of construction, the applicant shall prepare and submit a Storm Water Pollution Prevention Plan (SWPPP) to be executed through all phases of grading and project construction. The SWPPP shall incorporate Best Management Practices (BMPs) to ensure that potential water quality impacts during construction phases are minimized. These measures shall be consistent with the County’s Improvement Standards and Land Grading and Erosion Control Ordinance and the requirements of the National Pollution Discharge Elimination System (NPDES) General Permit for Storm Water Discharges Associated with Construction and Land Disturbance Activities. Prior to project construction the SWPPP shall be submitted to the County for review and to the Central Valley Regional Water Quality Control Board as required by the NPDES General Permit in effect during construction. During construction, the applicant shall implement actions and procedures established in the SWPPP to reduce the pollutant loadings in storm drain systems. The project applicant shall implement BMPs in accordance with the SWPPP and the County’s Improvement Standards. The project applicant(s) shall submit a state storm water permit Waste Discharger Identification number for project construction.</p> <p>NPDES GENERAL CONSTRUCTION PERMIT – Since the project size is more than one acre, prior to construction the applicant shall file a Notice of Intent with the Central Valley RWQCB to obtain coverage under the California State Water Resources - General Construction Activity Storm Water Permit. Permits are issued by the State Water Resources Control Board, which can provide all information necessary to complete and file the necessary documents. The applicant shall comply with the terms of the General Construction Permit, the County’s ordinances, and the</p>	<p>Prior to the start of construction and during construction</p>	<p>RWQCB/  Development Services Engineering Division</p>

Mitigation Measure	Timing	Monitoring Agency
NPDES Waste Discharge Requirements for the Sutter County Phase II NPDES Permit.		
<p><b>Mitigation Measure No. 5 (Hazards and Hazardous Materials):</b> Prior to the start of project construction, the developer shall conduct a limited sampling of the surface soil of the project site to determine the presence of residual pesticides, including but not limited to organochlorines. The samples shall be analyzed using California Department of Toxic Substances Control (DTSC) screening levels established for residential projects in Human Health Risk Assessment Note Number 3: DTSC-Modified Screening Levels, June 2020, or by U.S. Environmental Protection Agency Regional Screening Levels if screening levels are not established in HHRA Note Number 3. If no pesticide contamination is found or does not exceed applicable screening levels, then no further action need be taken. If pesticide contamination is identified and found to exceed the applicable screening level, then a Phase II Environmental Site Assessment shall be conducted for the property/properties on which this contamination was identified. The Phase II Environmental Site Assessment shall identify the extent of the contamination and shall recommend measures to remediate soil contamination to below applicable screening levels. The developer shall implement these actions prior to the start of construction.</p>	Prior to the start of construction	Development Services
<p><b>Mitigation Measure No. 6 (Hydrology and Water Quality):</b> DRAINAGE STUDY. Prior to issuance of a grading permit or encroachment permit, the applicant shall obtain approval from the Director of a drainage study that reflects final design conditions for the proposed project per County Standards. The Drainage Study shall be completed and stamped by a Professional Engineer and determined by the County to be comprehensive, accurate, and adequate (SCIS Section 9).</p>	Prior to issuance of a grading permit	Development Services Engineering Division
<p><b>Mitigation Measure No. 7 (Hydrology and Water Quality):</b> PRIVATE DRAINAGE IMPROVEMENTS. Prior to commercial use of the site, the applicant shall construct private onsite drainage ditches/basins that provide storm water retention/detention per a County-approved drainage study for this project. Owner shall limit maximum discharge rates, where applicable, to</p>	Prior to commercial use of the site	Development Services Engineering Division

Mitigation Measure	Timing	Monitoring Agency
<p>pre-project "existing" conditions for peak 10- and 100-year storms per an approved on-site drainage study for the project. The drainage ditches/basins shall not be connected to the roadside swales. The applicant must obtain a grading permit from the County prior to any grading for storm water retention/detention ditches or basins. The applicant shall provide an as-built drawing of the drainage improvements that is stamped and signed by a licensed Engineer verifying that what was constructed complies with the approved plan for the site.</p>		
<p><b>Mitigation Measure No. 8 (Hydrology and Water Quality):</b> PRIVATE DRAINAGE FACILITIES MAINTENANCE AGREEMENT. The property owner shall enter into an agreement with Sutter County committing the property owners and all successors-in-interest to maintain the private drainage facilities (including on-site peak flow attenuation basins) in perpetuity in a manner to preserve storage capacity, drainage patterns, ultimate discharge points and quantities, and water quality treatment controls for stormwater discharges as identified in the drainage study and approved by Sutter County.</p>	<p>Prior to commercial use of the site</p>	<p>Development Services Engineering Division</p>
<p><b>Mitigation Measure No. 9 (Hydrology and Water Quality):</b> GRADING AND CONSTRUCTION. All impacts to the site must be mitigated in the project area or lands acquired for mitigation by the project. Any Grading or Site Improvements shall be done per an approved plan and in accordance with Sutter County Development Standards. Plans shall be reviewed and approved for construction by the Director of Development Services prior to the start of construction.</p>	<p>Prior to start of construction and during construction</p>	<p>Development Services Engineering Division</p>
<p><b>Mitigation Measure No. 10 (Noise):</b> During construction, the applicant shall ensure that all project related noise-generating construction activities are limited to daytime hours between 7:00 a.m. and 6:00 p.m. on weekdays, 8:00 a.m. and 5:00 p.m. on Saturdays, and are prohibited on Sundays and holidays unless permission for the latter has been applied for and granted by the County.</p>	<p>Upon start of construction activities</p>	<p>Development Services</p>
<p><b>Mitigation Measure No. 11 (Transportation):</b> Prior to commercial use of the site and prior to use of this facility by Surface Transportation Assistance Act</p>	<p>Prior to commercial use and prior to use</p>	<p>Development Services/Caltrans</p>

Mitigation Measure	Timing	Monitoring Agency
(STAA) trucks, the applicant must show that the site has access to an established STAA route with the proper signage in place. In addition, the applicant must submit and obtain approval of a STAA route access plan which shows the STAA route to be used by the facility.	of the site by STAA trucks	
<b>Mitigation Measure No. 12 (Tribal Cultural Resources):</b> After the removal of the orchard trees, but prior to any grading, earthwork, or other soil disturbing activities, the applicant shall contact the Development Services Department so that a United Auburn Indian Community (UAIC) Tribal Representative or Tribal Monitor can be invited to inspect the project site. During this inspection, a UAIC Tribal Representative or Tribal Monitor may provide an on-site meeting for construction personnel information on TCRs and worker awareness brochures.	After removal of trees, but prior to start of grading activities	Development Services
<b>Mitigation Measure No. 13 (Tribal Cultural Resources):</b> If any suspected tribal cultural resources (TCRs) are discovered during project ground disturbing construction activities, all work shall cease within 100 feet of the find, or an agreed upon distance based on the project area and nature of the find. A Tribal Representative from a California Native American tribe that is traditionally and culturally affiliated with a geographic area shall be immediately notified and shall determine if the find is a TCR (PRC §21074). The Tribal Representative shall make recommendations for further evaluation and treatment as necessary.  When avoidance is infeasible, preservation in place is the preferred option for mitigation of TCRs under CEQA, and every effort shall be made to preserve the resources in place, including through project redesign, if feasible. Culturally appropriate treatment may be, but is not limited to, processing materials for reburial, minimizing handling of cultural objects, leaving objects in place within the landscape, or returning objects to a location within the project area where they would not be subject to future impacts. Permanent curation of TCRs would not take place unless approved in writing by the California Native American Tribe that is traditionally and culturally affiliated with the project area.	During construction activities	Construction personnel

<b>Mitigation Measure</b>	<b>Timing</b>	<b>Monitoring Agency</b>
<p>The contractor shall implement any measures deemed by the CEQA lead agency to be necessary and feasible to preserve in place, avoid, or minimize impacts to the resource, including, but not limited to, facilitating the appropriate tribal treatment of the find, as necessary. Treatment that preserves or restores the cultural character and integrity of a TCR may include tribal monitoring, culturally appropriate recovery of cultural objects, and reburial of cultural objects or cultural soil. Work at the discovery location shall not resume until all necessary investigation and evaluation of the discovery under the requirements of the CEQA, including AB 52, have been satisfied.</p>		

APPENDIX A  
PROJECT DRAWINGS

**ZONING CRITERIA:**  
 ZONING: AG  
 GENERAL: AG (80 AC. MIN.)  
 TOTAL SITE AREA: 14.08 ACRES  
 FLOOD ZONE: LOCAL FLOOD HAZARD AREA

- C1.0 SITE PLAN (w/o IMAGE)  
 C1.1 SITE PLAN (w/ IMAGE)  
 C1.2 ARCHITECTURAL SITE PLAN  
 C2 TRUCK TURNING PLAN  
 C3 TRUCK TURNING PLAN  
 C4 GRADING AND DRAINAGE PLAN  
 L1 LANDSCAPING PLAN  
 P1 PHOTOMETRIC PLAN  
 P2 PHOTOMETRIC DETAILS

REVISIONS	
A	
B	
C	
D	
E	

VERIFY SCALE BAR IS ONE INCH ON ORIGINAL DRAWING  
 IF NOT ONE INCH ON THIS SHEET, ADJUST SCALE(S) ACCORDINGLY

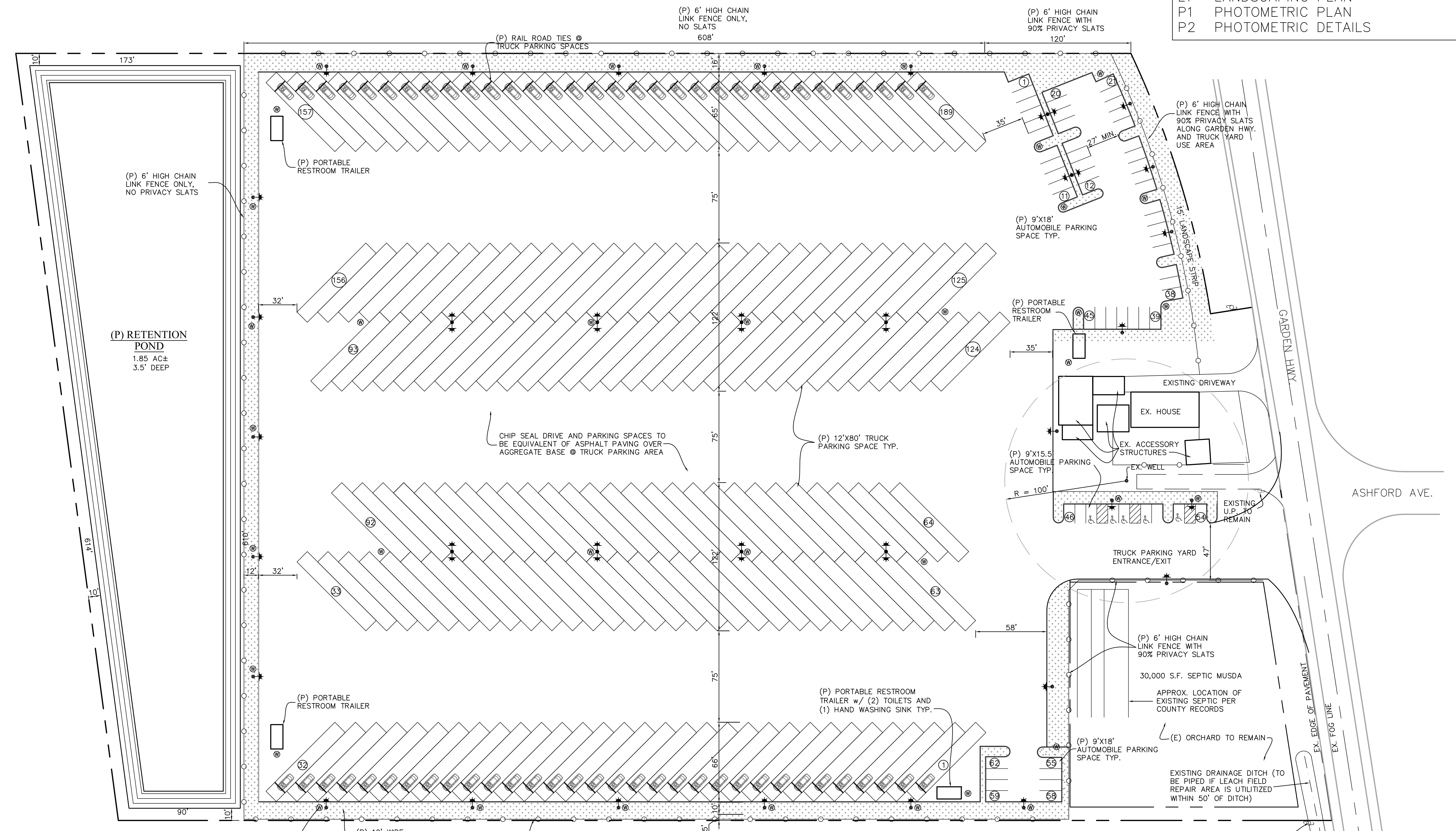

"W" = 3' DIA. 55 GAL. DRUM FOR WASTE DISPOSAL; 1 AT EACH LIGHT POLE IN LANDSCAPING AREA AT THE TRUCK PARKING AREA (18 TOTAL), 1 AT EACH RESTROOM AREA, AND 3 AT THE EAST AUTOMOBILE PARKING AREA, 4 AT THE NORTH AUTOMOBILE PARKING AREA, 1 AT THE SOUTH AUTOMOBILE PARKING AREA, 1 AT EACH END AND 2 MIDDLE OF TRUCK PARKING ISLE (8 TOTAL); 38 TOTAL

(P) 10' WIDE LANDSCAPE STRIP TYP.  
 (P) PORTION OF 6' HIGH CHAIN LINK FENCE ONLY, NO PRIVACY SLATS

**GENERAL NOTES:**  
 1. NO TRUCK REFRIGERATION UNITS WILL BE PRESENT ONSITE.  
 2. ALL TRUCK ENGINES ON SITE WILL BE 2014 OR NEWER.  
 3. NO ACCESS GATE WILL BE PROVIDED AT FRONT DRIVEWAY.

**PORTABLE RESTROOM NOTES:**  
 1 PORTABLE RESTROOM PER 25 TRUCK SPACES  
 189 TRUCK SPACES/25 = 7.6 REQUIRED  
 8 TOILETS PROPOSED > 7.6 REQUIRED  
 EACH PORTABLE RESTROOM SHALL INCLUDE A (2) TOILETS AND HAND WASHING STATION.  
 PORTABLE RESTROOMS SHALL NOT BE VISIBLE FROM THE PUBLIC RIGHT-OF-WAY.  
 PORTABLE RESTROOMS SHALL BE ACCESSIBLE 24 HOURS A DAY, 7 DAYS A WEEK.

**PARKING NOTES:**  
 1 AUTOMOBILE SPACE PER 1.5 TRUCK SPACES  
 189 TRUCK SPACES/1.5 = 126 AUTOMOBILE SPACES  
 FOR 126 AUTOMOBILE PARKING SPACES: 5 ACCESSIBLE PARKING SPACES ARE REQUIRED  
 62 PROPOSED AUTOMOBILE PARKING SPACES PROPOSED WITH 64 AUTOMOBILES TO PARK IN TRUCK PARKING SPACES.  
 FOR 101-150 AUTOMOBILE PARKING SPACES, 5 ACCESSIBLE SPACES ARE REQUIRED; 5 ACCESSIBLE SPACES PROPOSED

PROPOSED TRUCK YARD SITE PLAN FOR:  
**HSD TRUCKING**  
 8645 GARDEN HIGHWAY, SUTTER COUNTY  
 APN: 25-0904-029

**LAUGHLIN and SPENCE**  
 CIVIL ENGINEERS & SURVEYORS  
 1008 Live Oak Boulevard  
 Yuba City, California 95991  
 (530) 671 1008  
 fax (530) 671 0822



THESE PLANS ARE CONSIDERED "PRELIMINARY" OR "FOR REVIEW" UNLESS WET SIGNED AND SEALED BY THE ENGINEER. THEY SHALL NOT BE USED FOR CONSTRUCTION UNLESS STAMPED APPROVED BY THE LOCAL AGENCY.

Date: 4-24-22  
 Scale: 1"=40'  
 Drawn: JWS, BM  
 Job: 217191  
 Sheet:

**C1.0**  
 Page 1 OF 9

S:\1000\217000\217191\_Sdbs - Tuber\_L\dwg\Master.dwg 04/28/22 09:31 am\25020-1

THIS IS NOT AN ENGINEERED SITE SURVEY. PROPERTY BOUNDARIES ARE BASED ON PREVIOUS RECORD MAP. STRUCTURE LOCATIONS SHOWN ON THIS DRAWING HAVE NOT BEEN SURVEYED IN RELATION TO PROPERTY LINES.

**SITE PLAN (NO IMAGE)**

**ZONING CRITERIA:**  
 ZONING: AG  
 GENERAL PLAN: AG (80 AC. MIN.)  
 TOTAL SITE AREA: 14.08 ACRES  
 FLOOD ZONE: LOCAL FLOOD HAZARD AREA

- C1.0 SITE PLAN (w/o IMAGE)  
 C1.1 SITE PLAN (w/ IMAGE)  
 C1.2 ARCHITECTURAL SITE PLAN  
 C2 TRUCK TURNING PLAN  
 C3 TRUCK TURNING PLAN  
 C4 GRADING AND DRAINAGE PLAN  
 L1 LANDSCAPING PLAN  
 P1 PHOTOMETRIC PLAN  
 P2 PHOTOMETRIC DETAILS

REVISIONS	
A	
B	
C	
D	
E	

VERIFY SCALE BAR IS ONE INCH ON ORIGINAL DRAWING  
 IF NOT ONE INCH ON THIS SHEET, ADJUST SCALE(S) ACCORDINGLY

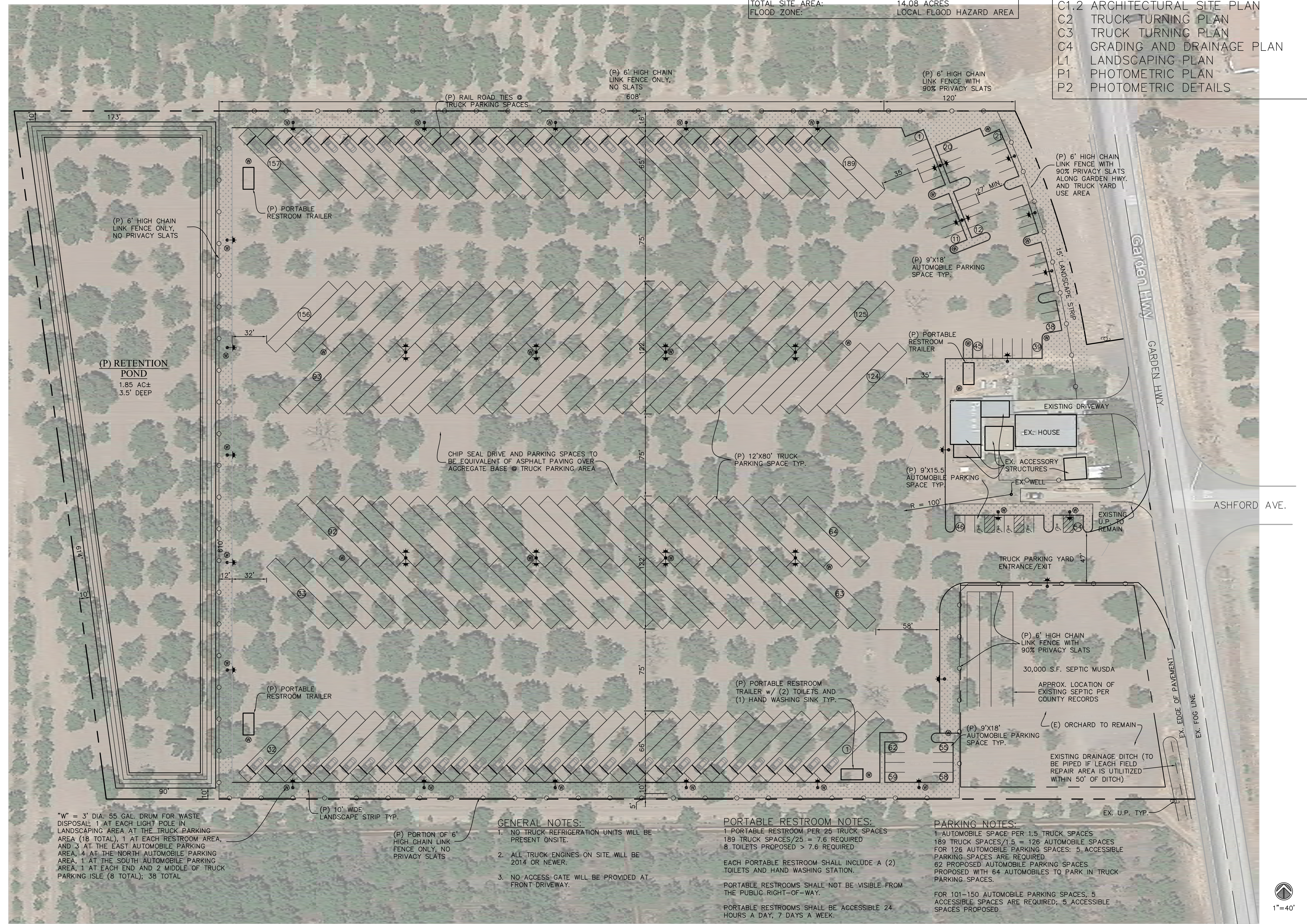

"W" = 3' DIA. 55 GAL. DRUM FOR WASTE DISPOSAL; 1 AT EACH LIGHT POLE IN LANDSCAPING AREA AT THE TRUCK PARKING AREA (18 TOTAL), 1 AT EACH RESTROOM AREA, AND 3 AT THE EAST AUTOMOBILE PARKING AREA, 4 AT THE NORTH AUTOMOBILE PARKING AREA, 1 AT THE SOUTH AUTOMOBILE PARKING AREA, 1 AT EACH END AND 2 MIDDLE OF TRUCK PARKING ISLE (8 TOTAL); 38 TOTAL

(P) PORTION OF 6' HIGH CHAIN LINK FENCE ONLY, NO PRIVACY SLATS

- GENERAL NOTES:**
- NO TRUCK REFRIGERATION UNITS WILL BE PRESENT ONSITE.
  - ALL TRUCK ENGINES ON SITE WILL BE 2014 OR NEWER.
  - NO ACCESS GATE WILL BE PROVIDED AT FRONT DRIVEWAY.

**PORTABLE RESTROOM NOTES:**  
 1 PORTABLE RESTROOM PER 25 TRUCK SPACES  
 189 TRUCK SPACES/25 = 7.6 REQUIRED  
 8 TOILETS PROPOSED > 7.6 REQUIRED

EACH PORTABLE RESTROOM SHALL INCLUDE A (2) TOILETS AND HAND WASHING STATION.

PORTABLE RESTROOMS SHALL NOT BE VISIBLE FROM THE PUBLIC RIGHT-OF-WAY.

PORTABLE RESTROOMS SHALL BE ACCESSIBLE 24 HOURS A DAY, 7 DAYS A WEEK.

**PARKING NOTES:**  
 1 AUTOMOBILE SPACE PER 1.5 TRUCK SPACES  
 189 TRUCK SPACES/1.5 = 126 AUTOMOBILE SPACES  
 FOR 126 AUTOMOBILE PARKING SPACES: 5 ACCESSIBLE PARKING SPACES ARE REQUIRED  
 62 PROPOSED AUTOMOBILE PARKING SPACES  
 PROPOSED WITH 64 AUTOMOBILES TO PARK IN TRUCK PARKING SPACES.

FOR 101-150 AUTOMOBILE PARKING SPACES, 5 ACCESSIBLE SPACES ARE REQUIRED; 5 ACCESSIBLE SPACES PROPOSED

4/26/2024 10:00:00 AM 217191 5648 - Tuser\_LJ\pjs\Master.dwg 04/26/24 09:31 am 1625202-1

THIS IS NOT AN ENGINEERED SITE SURVEY. PROPERTY BOUNDARIES ARE BASED ON PREVIOUS RECORD MAP. STRUCTURE LOCATIONS SHOWN ON THIS DRAWING HAVE NOT BEEN SURVEYED IN RELATION TO PROPERTY LINES.

PROPOSED TRUCK YARD SITE PLAN FOR:  
**HSD TRUCKING**  
 8645 GARDEN HIGHWAY, SUTTER COUNTY  
 APN: 25-0904-029

**LAUGHLIN and SPENCE**  
 CIVIL ENGINEERS & SURVEYORS  
 1008 Live Oak Boulevard  
 Yuba City, California 95991  
 (530) 671 1008  
 fax (530) 671 0822

THESE PLANS ARE CONSIDERED "PRELIMINARY" OR "FOR REVIEW" UNLESS WET SIGNED AND SEALED BY THE ENGINEER. THEY SHALL NOT BE USED FOR CONSTRUCTION UNLESS STAMPED APPROVED BY THE LOCAL AGENCY.

Date: 4-24-22  
 Scale: 1"=40'  
 Drawn: JWS,BM  
 Job: 217191  
 Sheet:

**C1.1**  
 Page 2 OF 9

**SITE PLAN (IMAGE)**

S:\0000\217000\217191\_Site - Tutor\_Landscape\Master.dwg 04/28/22 09:40 am MS2025-1

REVISIONS	
A	
B	
C	
D	
E	

VERIFY SCALE BAR IS ONE INCH ON ORIGINAL DRAWING  
 0 1"  
 IF NOT ONE INCH ON THIS SHEET, ADJUST SCALE(S) ACCORDINGLY

PROPOSED TRUCK YARD SITE PLAN FOR:  
**HSD TRUCKING**  
 8645 GARDEN HIGHWAY, SUTTER COUNTY  
 APN: 25-090-029

**LAUGHLIN and SPENCE**  
 CIVIL ENGINEERS & SURVEYORS  
 1008 Live Oak Boulevard  
 Yuba City, California 95991  
 (530) 671 1008  
 fax (530) 671 0822



THESE PLANS ARE CONSIDERED "PRELIMINARY" OR "FOR REVIEW" UNLESS WET SIGNED AND SEALED BY THE ENGINEER. THEY SHALL NOT BE USED FOR CONSTRUCTION UNLESS STAMPED APPROVED BY THE LOCAL AGENCY.

Date 4-24-22  
 Scale 1"=40'  
 Drawn JWS, BM  
 Job 217191  
 Sheet **C1.2**  
 Page 3 OF 9

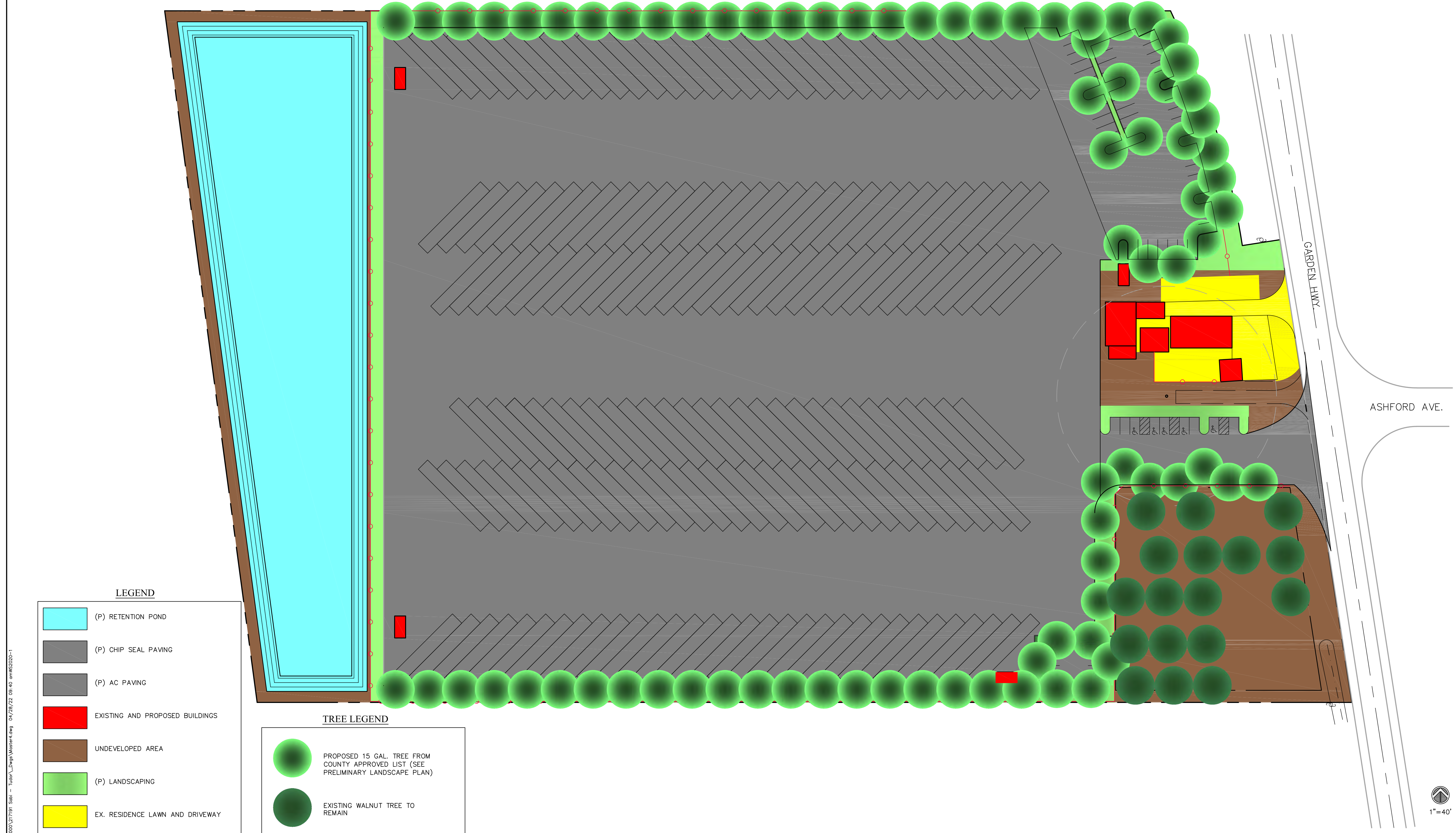

**LEGEND**

- (P) RETENTION POND
- (P) CHIP SEAL PAVING
- (P) AC PAVING
- EXISTING AND PROPOSED BUILDINGS
- UNDEVELOPED AREA
- (P) LANDSCAPING
- EX. RESIDENCE LAWN AND DRIVEWAY

**TREE LEGEND**

- PROPOSED 15 GAL. TREE FROM COUNTY APPROVED LIST (SEE PRELIMINARY LANDSCAPE PLAN)
- EXISTING WALNUT TREE TO REMAIN

**ARCHITECTURAL SITE PLAN**



S:\1000\217000\217191\_Site - Tutor\_Laughlin\Master.dwg 04/28/22 08:35 am\625025-1

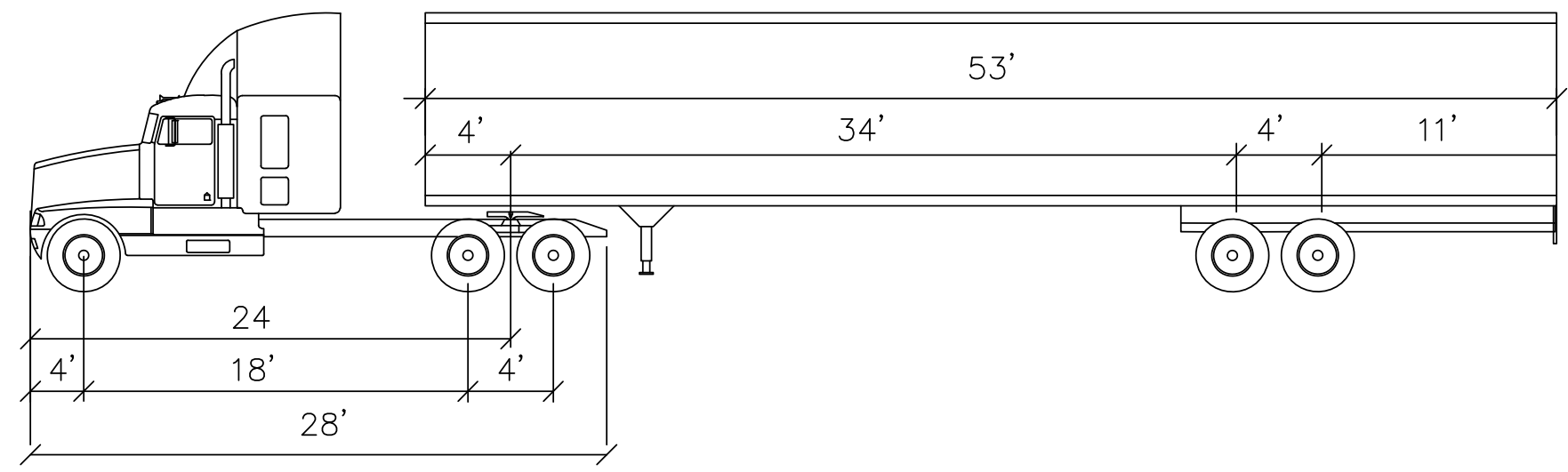
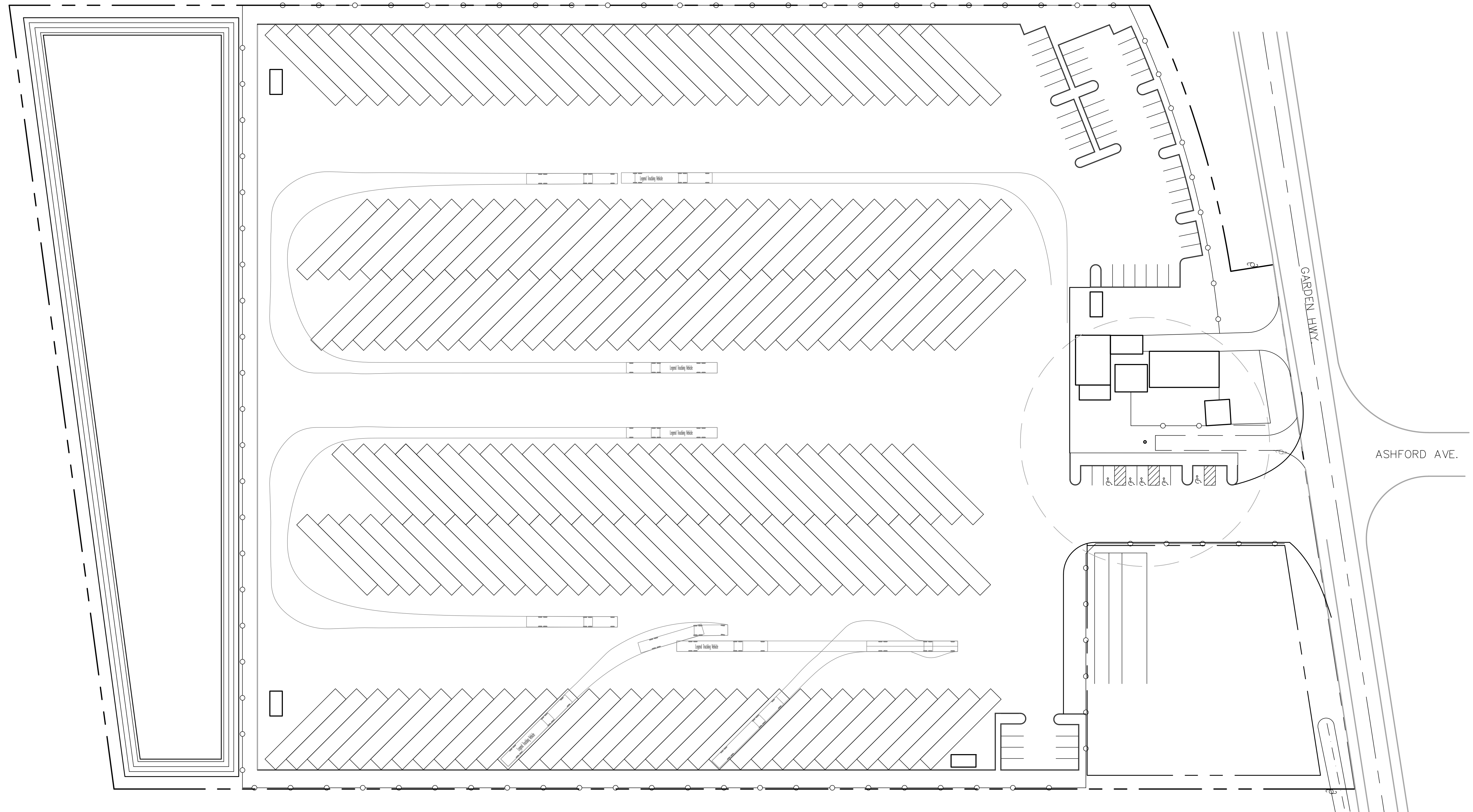

"TYPICAL LOCAL" STAA TRUCK

1"=40'

TRUCK TURNING PLAN

REVISIONS	
A	.
B	.
C	.
D	.
E	.

VERIFY SCALE BAR IS ONE INCH ON ORIGINAL DRAWING  
 0 1"  
 IF NOT ONE INCH ON THIS SHEET, ADJUST SCALE(S) ACCORDINGLY

PROPOSED TRUCK YARD SITE PLAN FOR:  
**HSD TRUCKING**  
 8645 GARDEN HIGHWAY, SUTTER COUNTY  
 APN: 25-090-029

**LAUGHLIN and SPENCE**  
 CIVIL ENGINEERS & SURVEYORS  
 1008 Live Oak Boulevard  
 Yuba City, California 95991  
 (530) 671 1008  
 fax (530) 671 0822



THESE PLANS ARE CONSIDERED "PRELIMINARY" OR "FOR REVIEW" UNLESS WET SIGNED AND SEALED BY THE ENGINEER. THEY SHALL NOT BE USED FOR CONSTRUCTION UNLESS STAMPED APPROVED BY THE LOCAL AGENCY.

Date 4-24-22  
 Scale 1"=40'  
 Drawn JWS, BM  
 Job 217191  
 Sheet

**C2**

S:\V000\217000\217191\_Site - Tuser\_L\Draws\Master.dwg 04/28/22 08:35 am\625026-1

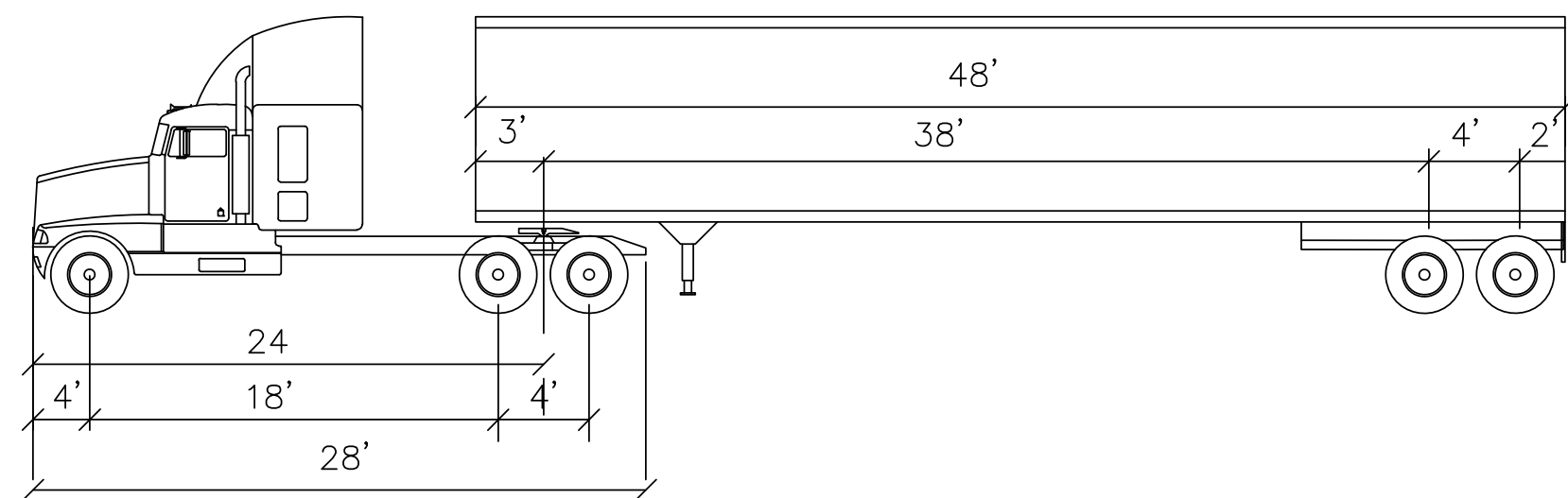
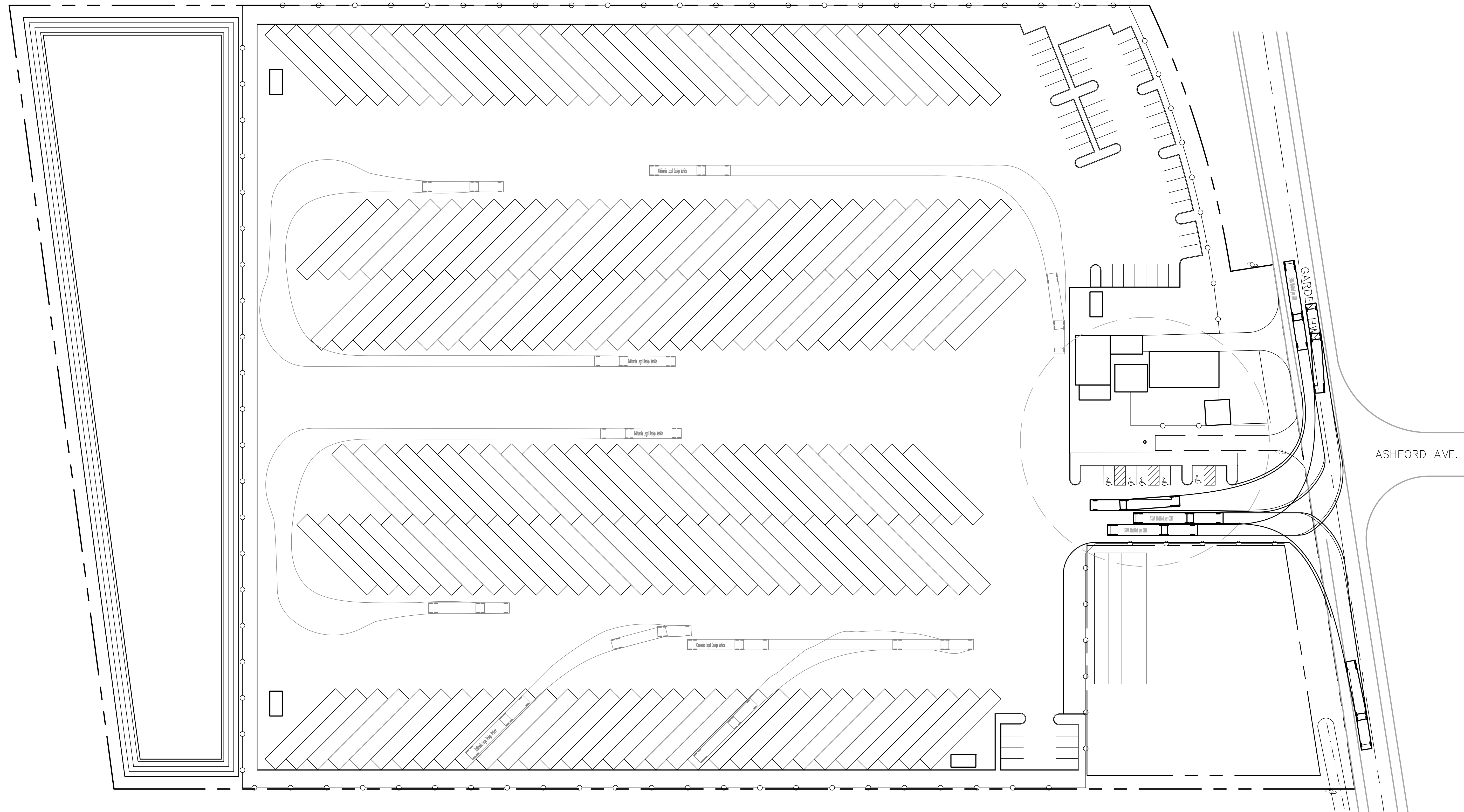

"CALTRANS STAA" DESIGN TRUCK



TRUCK TURNING PLAN

REVISIONS	
A	
B	
C	
D	
E	

VERIFY SCALE BAR IS ONE INCH ON ORIGINAL DRAWING  
 0 1"  
 IF NOT ONE INCH ON THIS SHEET, ADJUST SCALE(S) ACCORDINGLY

PROPOSED TRUCK YARD SITE PLAN FOR:  
**HSD TRUCKING**  
 8645 GARDEN HIGHWAY, SUTTER COUNTY  
 APN: 25-0904029

**LAUGHLIN and SPENCE**  
 CIVIL ENGINEERS & SURVEYORS  
 1008 Live Oak Boulevard  
 Yuba City, California 95991  
 (530) 671 1008  
 fax (530) 671 0822

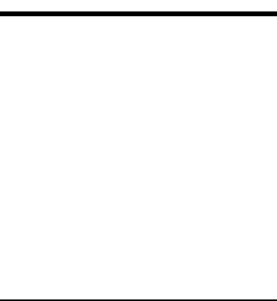

THESE PLANS ARE CONSIDERED "PRELIMINARY" OR "FOR REVIEW" UNLESS WET SIGNED AND SEALED BY THE ENGINEER. THEY SHALL NOT BE USED FOR CONSTRUCTION UNLESS STAMPED APPROVED BY THE LOCAL AGENCY.

Date 4-24-22  
 Scale 1"=40'  
 Drawn JWS, BM  
 Job 217191  
 Sheet

**C3**  
 Page 5 OF 9

REVISIONS	
A	
B	
C	
D	
E	

VERIFY SCALE BAR IS ONE INCH ON ORIGINAL DRAWING  
 IF NOT ONE INCH ON THIS SHEET, ADJUST SCALE(S) ACCORDINGLY

PROPOSED TRUCK YARD SITE PLAN FOR:  
**HSD TRUCKING**  
 8645 GARDEN HIGHWAY, SUTTER COUNTY  
 ATN: 25-0904029

**LAUGHLIN and SPENCE**  
 CIVIL ENGINEERS & SURVEYORS  
 1008 Live Oak Boulevard  
 Yuba City, California 95991  
 (530) 671 1008  
 fax (530) 671 0822



THESE PLANS ARE CONSIDERED "PRELIMINARY" OR "FOR REVIEW" UNLESS WET SIGNED AND SEALED BY THE ENGINEER. THEY SHALL NOT BE USED FOR CONSTRUCTION UNLESS STAMPED APPROVED BY THE LOCAL AGENCY.

Date: 4-24-22  
 Scale: 1"=40'  
 Drawn: JWS, BM  
 Job: 217191  
 Sheet: C4

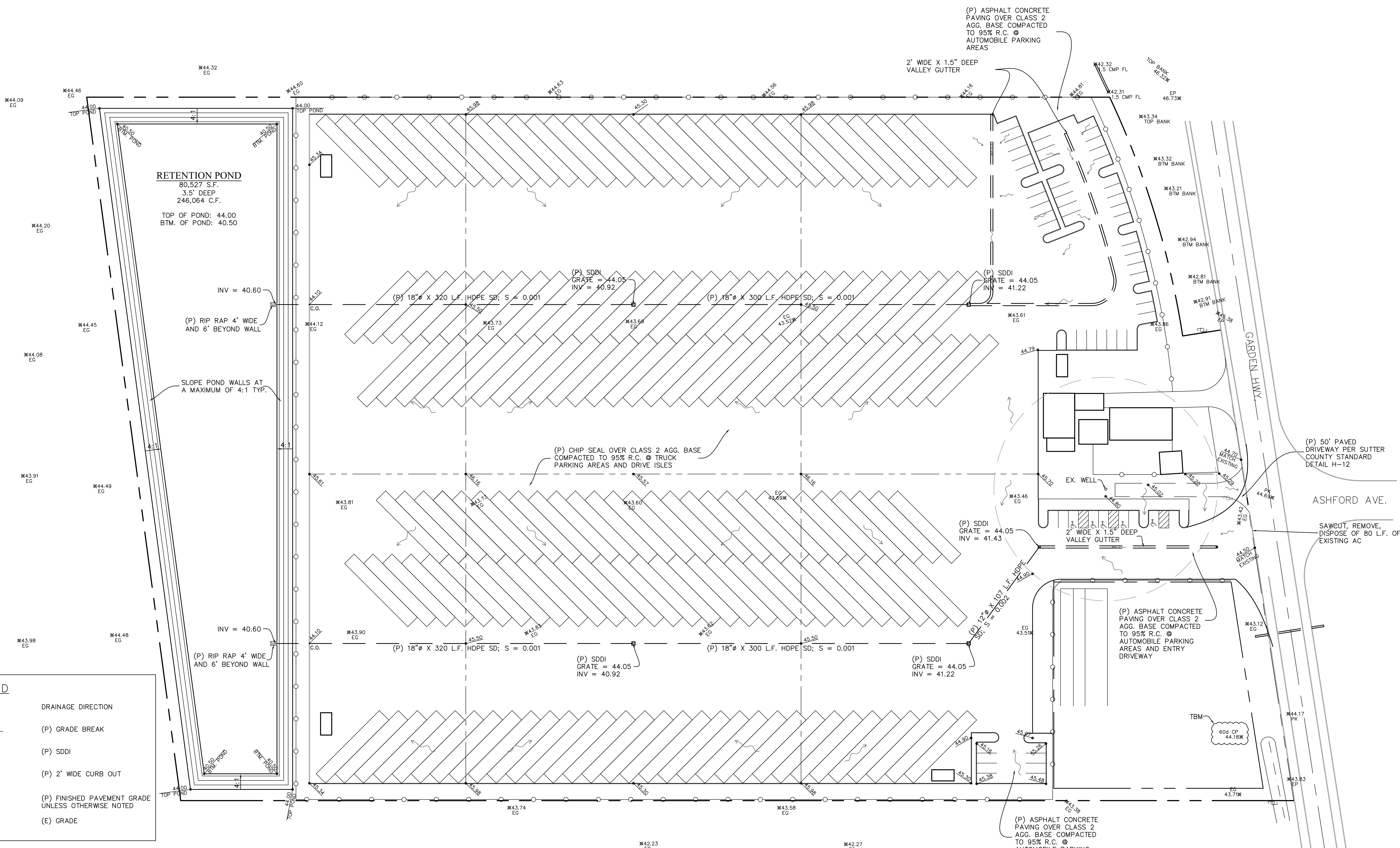

**GRADING AND DRAINAGE PLAN**

S:\V000\217000\217191\_Subs - Tutor\_L\Draws\Master.dwg 04/26/22 08:34 omw52020-1

Reference Evapotranspiration (ET<sub>o</sub>) **46.7** (Table A)

Hydrozone # / Planting Description <sup>a</sup>	Plant Factor (PF)	Irrigation Method <sup>b</sup>	Irrigation Efficiency (IE) <sup>c</sup>	ETAF (PF/IE)	Landscape Area (sq. ft.)	ETAF x Area	Estimated Total Water Use (ETWU) <sup>d</sup>
<b>Regular Landscape Areas</b>							
LOW WATER USE PLANTINGS	0.3	DRIP	0.81	0.37	39,953	14,797.41	428,444.13
LOW WATER USE PLANTINGS	0.3	DRIP	0.81	0.37	0	0.00	0.00
LAWN	0.6	OVERHEAD SPRAY	0.75	0.80	0	0.00	0.00
<b>Totals</b>					39953	14797.41	

**Special Landscape Areas**

Hydrozone # / Planting Description <sup>a</sup>	Plant Factor (PF)	Irrigation Method <sup>b</sup>	Irrigation Efficiency (IE) <sup>c</sup>	ETAF (PF/IE)	Landscape Area (sq. ft.)	ETAF x Area	Estimated Total Water Use (ETWU) <sup>d</sup>
<b>Totals</b>					0	0	0
					(C)	(D)	
							ETWU Total
							428,444.13
							<b>Maximum Allowed Water Allowance (MAWA)<sup>e</sup></b>
							520,559.62

<sup>a</sup> Hydrozone # / Planting Description  
 e.g. 1) Front Lawn  
 2) Low water use plantings  
 3) Medium water use plantings

<sup>b</sup> Irrigation Method  
 overhead spray or drip

<sup>c</sup> Irrigation Efficiency  
 0.75 for spray head  
 0.81 for drip

<sup>d</sup> ETWU (Annual Gallons Required)  
 ETWU = 0.62 \* ETAF \* Area  
 where 0.62 is a conversion factor that converts acre-inches per acre per year to gallons per square foot per year

<sup>e</sup> MAWA (Annual Gallon Allowed)  
 (ET<sub>o</sub>) (0.62) [(ETAF \* LA) + ((1 - ETAF) \* SLA)]  
 where 0.62 is a conversion factor that converts acre-inches per acre per year to gallons per square foot per year, LA is the total landscape area in sq. ft., SLA is the total special landscape area in sq. ft., and ETAF is 0.55 for residential areas and 0.45 for non-residential areas

**ETAF Calculations**

Regular Landscape Areas	Total ETAF x Area	14797.41	(B)	Average ETAF for Regular Landscape Areas must be 0.55 or below for residential areas, and 0.45 or below for non-residential areas
Total Area	39953	(A)		
Average ETAF	0.37	B/A		

**All Landscape areas**

Total ETAF x Area	14797.41	(B+D)
Total Area	39953	(A+C)
Site-wide ETAF	0.37	(B+D)/(A+C)

**PARKING SHADING ANALYSIS**

TOTAL AUTOMOBILE PARKING AREA: 33,144 S.F.  
 SHADING REQUIRED = 50% OF PARKING AREA  
 16,572 S.F. REQUIRED  
 19,614 S.F. PROVIDED

**LANDSCAPING NOTES:**

- ALL LANDSCAPING SHALL BE WITHIN PLANTERS SEPARATED FROM REQUIRED PARKING AND DRIVEWAYS WITH 6" HIGH X 6" WIDE CONTINUOUS CONCRETE CURB. NO PLANTER SHALL BE SMALLER THAN 25 SQUARE FEET, EXCLUDING CURBING. EACH PLANTER SHALL INCLUDE AN IRRIGATION SYSTEM.
- NOT MORE THAN 25 PERCENT OF ANY PLANTER OR LANDSCAPED AREA SHALL BE COVERED WITH HARD SURFACES SUCH AS GRAVEL, LANDSCAPING ROCK, ARTIFICIAL TURF, DECORATIVE CONCRETE OR OTHER IMPERVIOUS MATERIALS.
- LANDSCAPING AND LIGHTING PLANS SHALL BE COORDINATED SUCH THAT VEGETATION GROWTH WILL NOT INTERFERE WITH INTENDED ILLUMINATION OF SECURITY AND PARKING LOT LIGHTING.
- ANY AREAS ALONG GARDEN HWY. BETWEEN THE PROPERTY FRONTAGE FENCE AND FRONT PROPERTY LINE NOT LANDSCAPED SHALL BE TREATED FOR WEED CONTROL.

**PLANT LEGEND**

SYMBOL	NAME	QTY.	SIZE	REMARKS
•A	CHINESE PISTACHE (PISTACIA CHINENSIS)	42	15 GAL.	30' O.C. MAX.
•B	CALIFORNIA BAY TREE (UMBELLARIA CALIFORNICA)	38	15 GAL.	30' O.C. MAX.
•S1	PHOTINIA (PHOTINIA FRASERI)	45	5 GAL.	6' MIN. FROM TREES
•S2	GULF STREAM HEAVENLY BAMBOO (NANDINA DOMESTICA 'GULF STREAM')	36	5 GAL.	
•S3	DWARF OLIVE (OLEA EUROPAEA 'LITTLE OLIVE')	47	5 GAL.	
•S4	DWARF PINK INDIA HAWTHORNE (RHAPHIOLEPIS INDICA 'BALLERINA')	33	5 GAL.	

GROUND COVER AT LANDSCAPED AREAS TO BE BARK MULCH TYP.

**REVISIONS**

NO.	DESCRIPTION
A	
B	
C	
D	
E	

VERIFY SCALE BAR IS ONE INCH ON ORIGINAL DRAWING  
 IF NOT ONE INCH ON THIS SHEET, ADJUST SCALE(S) ACCORDINGLY

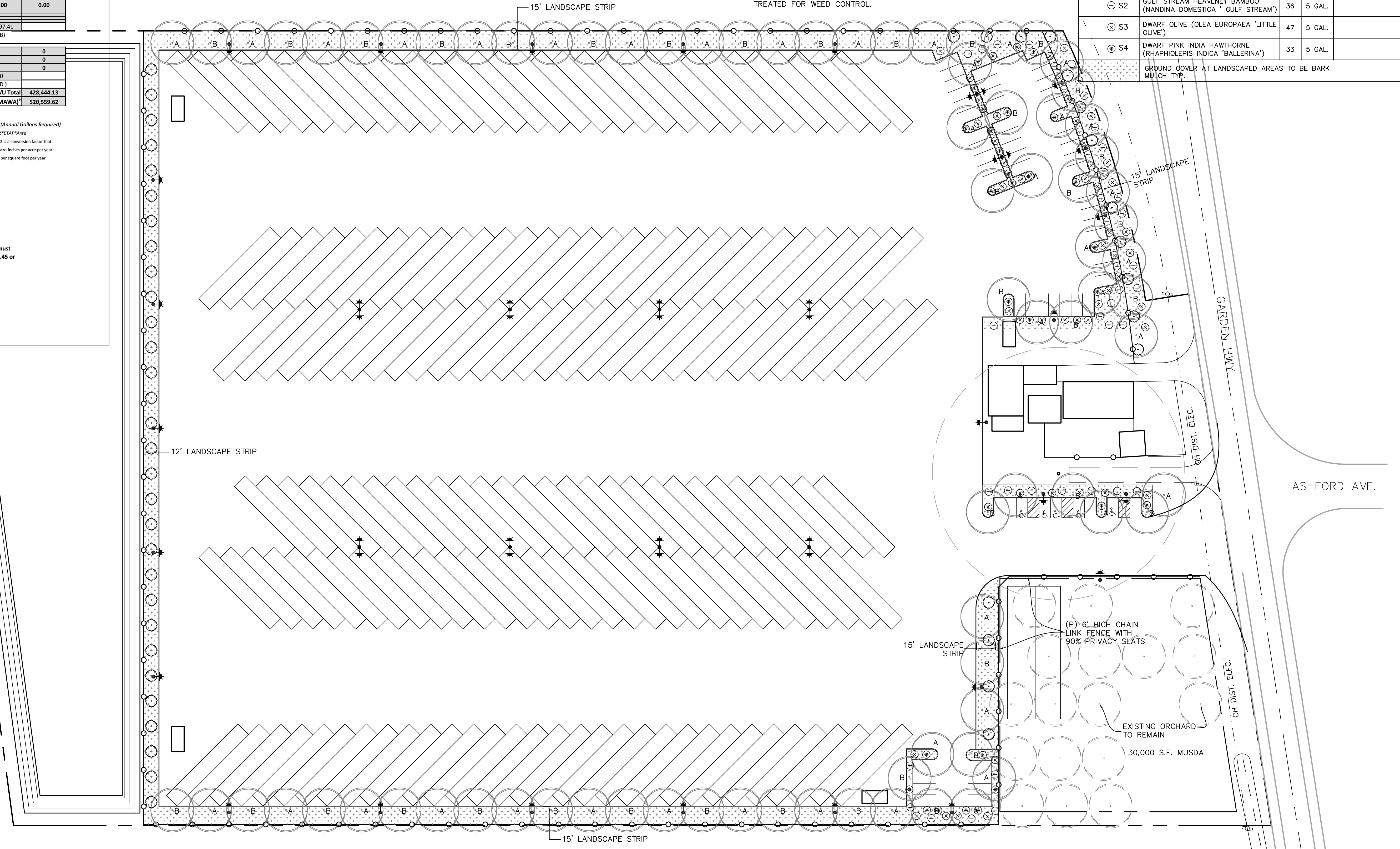

PROPOSED TRUCK YARD SITE PLAN FOR:  
**HSD TRUCKING**  
 8645 GARDEN HIGHWAY, SUTTER COUNTY  
 APN: 25-090-029

**LAUGHLIN and SPENCE**  
 CIVIL ENGINEERS & SURVEYORS  
 1008 Live Oak Boulevard  
 Yuba City, California 95991  
 (530) 671 1008  
 fax (530) 671 0822



THESE PLANS ARE CONSIDERED "PRELIMINARY" OR "FOR REVIEW" UNLESS WET SIGNED AND SEALED BY THE ENGINEER. THEY SHALL NOT BE USED FOR CONSTRUCTION UNLESS STAMPED APPROVED BY THE LOCAL AGENCY.

Date: 4-24-22  
 Scale: 1"=40'  
 Drawn: JWS, BM  
 Job: 217191  
 Sheet:

**L1**

**LANDSCAPING PLAN**



1"=40'

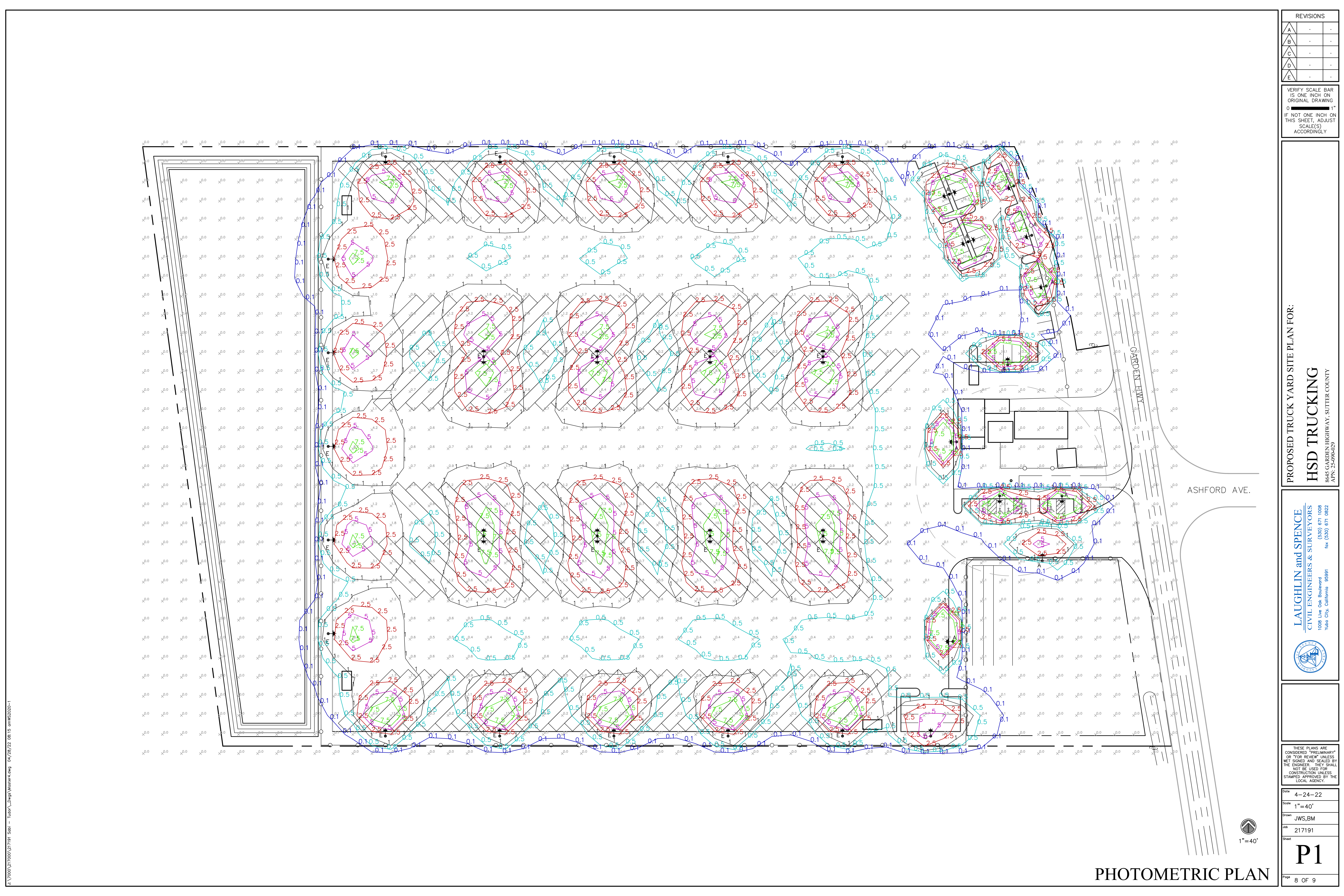

REVISIONS	
A	
B	
C	
D	
E	

VERIFY SCALE BAR IS ONE INCH ON ORIGINAL DRAWING  
 0 1"  
 IF NOT ONE INCH ON THIS SHEET, ADJUST SCALE(S) ACCORDINGLY

PROPOSED TRUCK YARD SITE PLAN FOR:  
**HSD TRUCKING**  
 8645 GARDEN HIGHWAY, SUTTER COUNTY  
 APN: 25-090429

**LAUGHLIN and SPENCE**  
 CIVIL ENGINEERS & SURVEYORS  
 1008 Live Oak Boulevard  
 Yuba City, California 95991  
 (530) 671 1008  
 fax (530) 671 0822



THESE PLANS ARE CONSIDERED "PRELIMINARY" OR "FOR REVIEW" UNLESS WET SIGNED AND SEALED BY THE ENGINEER. THEY SHALL NOT BE USED FOR CONSTRUCTION UNLESS STAMPED APPROVED BY THE LOCAL AGENCY.

Date 4-24-22  
 Scale 1"=40'  
 Drawn JWS,BM  
 Job 217191  
 Sheet

**P1**

S:\1000\217000\217191\Site - Tutor\_L\Draws\Master.dwg 04/26/22 08:15 am\ms2020-1

**PHOTOMETRIC PLAN**

Luminaire Locations										
No.	Label	Location					Aim			
		X	Y	Z	MH	Orientation	Tilt	X	Y	Z
8	E	6940.10	-1378.60	25.00	25.00	180.00	30.00	6940.10	-1393.03	0.00
9	E	7040.20	-1378.60	25.00	25.00	180.00	30.00	7040.20	-1393.03	0.00
10	E	7143.40	-1378.30	25.00	25.00	180.00	30.00	7143.40	-1392.73	0.00
11	E	7245.10	-1379.00	25.00	25.00	180.00	30.00	7245.10	-1393.43	0.00
12	E	7346.80	-1378.70	25.00	25.00	180.00	30.00	7346.80	-1393.13	0.00
13	E	7450.60	-1378.30	25.00	25.00	180.00	30.00	7450.60	-1392.73	0.00
18	E	7050.30	-1569.70	25.00	25.00	180.00	30.00	7050.30	-1584.13	0.00
19	E	7169.50	-1569.10	25.00	25.00	180.00	30.00	7169.50	-1583.53	0.00
20	E	7287.50	-1570.00	25.00	25.00	180.00	30.00	7287.50	-1584.43	0.00
21	E	7406.40	-1569.30	25.00	25.00	180.00	30.00	7406.40	-1583.73	0.00
25	E	7050.20	-1743.60	25.00	25.00	180.00	30.00	7050.20	-1758.03	0.00
26	E	7169.00	-1743.70	25.00	25.00	180.00	30.00	7169.00	-1758.13	0.00
27	E	7287.70	-1743.40	25.00	25.00	180.00	30.00	7287.70	-1757.83	0.00
28	E	7406.70	-1742.20	25.00	25.00	180.00	30.00	7406.70	-1756.63	0.00
31	E	6940.00	-1934.60	20.00	20.00	0.00	30.00	6940.00	-1923.05	0.00
32	E	7039.80	-1934.60	20.00	20.00	0.00	30.00	7039.80	-1923.05	0.00
33	E	7140.10	-1934.70	20.00	20.00	0.00	30.00	7140.10	-1923.15	0.00
34	E	7240.00	-1934.50	20.00	20.00	0.00	30.00	7240.00	-1922.95	0.00
35	E	7339.90	-1934.70	20.00	20.00	0.00	30.00	7339.90	-1923.15	0.00
36	E	7432.10	-1934.40	20.00	20.00	0.00	30.00	7432.10	-1922.85	0.00
37	E	6889.40	-1470.70	25.00	25.00	90.00	30.00	6903.83	-1470.70	0.00
38	E	7050.30	-1569.00	25.00	25.00	0.00	30.00	7050.30	-1554.57	0.00
39	E	7169.50	-1568.40	25.00	25.00	0.00	30.00	7169.50	-1553.97	0.00
40	E	7287.50	-1569.30	25.00	25.00	0.00	30.00	7287.50	-1554.87	0.00
41	E	7406.40	-1568.60	25.00	25.00	0.00	30.00	7406.40	-1554.17	0.00
42	E	6890.60	-1655.40	25.00	25.00	90.00	30.00	6905.03	-1655.40	0.00
43	E	6890.30	-1842.10	25.00	25.00	90.00	30.00	6904.73	-1842.10	0.00
44	E	6888.00	-1562.00	25.00	25.00	90.00	30.00	6902.43	-1562.00	0.00
45	E	7050.60	-1741.80	25.00	25.00	0.00	30.00	7050.60	-1727.37	0.00
46	E	7169.80	-1741.20	25.00	25.00	0.00	30.00	7169.80	-1726.77	0.00
47	E	7287.80	-1742.10	25.00	25.00	0.00	30.00	7287.80	-1727.67	0.00
48	E	7406.70	-1741.40	25.00	25.00	0.00	30.00	7406.70	-1726.97	0.00
49	E	6890.60	-1751.70	25.00	25.00	90.00	30.00	6905.03	-1751.70	0.00
1	A	7552.20	-1748.30	12.00	12.00	0.00	0.00	7552.20	-1748.30	0.00
2	A	7606.70	-1747.80	12.00	12.00	0.00	0.00	7606.70	-1747.80	0.00
3	A	7669.80	-1747.30	12.00	12.00	0.00	0.00	7669.80	-1747.30	0.00
4	A	7709.00	-1710.90	12.00	12.00	270.00	0.00	7709.00	-1710.90	0.00
5	C	7519.50	-1935.70	18.00	18.00	0.00	0.00	7519.50	-1935.70	0.00
6	A	7603.00	-1523.00	12.00	12.00	270.00	0.00	7603.00	-1523.00	0.00
7	A	7602.10	-1459.70	12.00	12.00	270.00	0.00	7602.10	-1459.70	0.00
8	A	7602.20	-1401.40	12.00	12.00	270.00	0.00	7602.20	-1401.40	0.00
9	A	7601.80	-1365.60	12.00	12.00	270.00	0.00	7601.80	-1365.60	0.00
10	A	7533.80	-1365.60	12.00	12.00	270.00	0.00	7533.80	-1365.60	0.00
11	A	7537.80	-1365.90	12.00	12.00	90.00	0.00	7537.80	-1365.90	0.00
12	A	7533.60	-1410.20	12.00	12.00	270.00	0.00	7533.60	-1410.20	0.00
13	A	7537.60	-1410.50	12.00	12.00	90.00	0.00	7537.60	-1410.50	0.00
14	A	7543.70	-1629.40	12.00	12.00	270.00	0.00	7543.70	-1629.40	0.00
15	A	7539.20	-1829.70	12.00	12.00	270.00	0.00	7539.20	-1829.70	0.00

Schedule						
Symbol	Label	QTY	Manufacturer	Catalog Number	Description	Wattage
	E	33	LITHONIA	RSXF1 LED P2 50K AWFV BV	RSXF Flood Fixture Size 1 P2 Lumens Package 5000K CCT Type AWFV Distribution with BV Shield	73
	A	15	LITHONIA	DSX1 LED P2 50K BLC MVOLT	DSX1 LED P2 50K BLC MVOLT	70
	C+	15	LITHONIA	DSX1 LED P2 50K BLC MVOLT	DSX1 LED P2 50K BLC MVOLT	70

\* LABEL "C" IS THE SAME LIGHT FIXTURE AS LABEL "A" BUT IS USED TO DIFFERENTIATE BETWEEN THE TWO DIFFERENT POLE HEIGHTS. SEE LOCATION SCHEDULE ABOVE.



## D-Series Size 1 LED Area Luminaire

**Specifications**

EPA: 1.01 ft<sup>2</sup> (0.09 m<sup>2</sup>)

Length: 33" (83.8 cm)

Width: 13" (33.0 cm)

Height H1: 7'-1 7/8" (194 cm)

Height H2: 3'-1/2" (107 cm)

Weight (max): 27 lbs (12.2 kg)

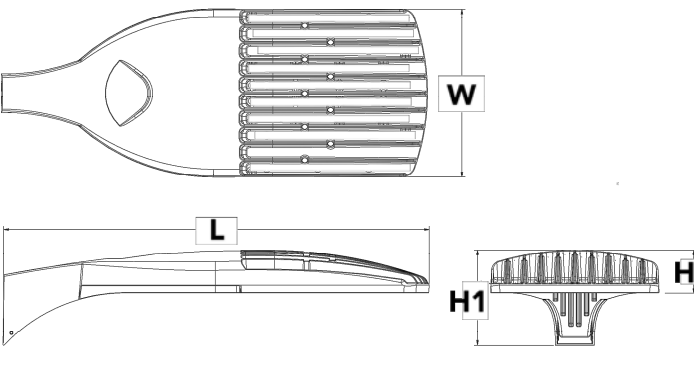

**Introduction**

The modern styling of the D-Series is striking yet unobtrusive - making a bold, progressive statement even as it blends seamlessly with its environment. The D-Series distills the benefits of the latest in LED technology into a high performance, high efficacy, long-life luminaire.

The outstanding photometric performance results in sites with excellent uniformity, greater pole spacing and lower power density. It is ideal for replacing up to 750W metal halide in pedestrian and area lighting applications with typical energy savings of 65% and expected service life of over 100,000 hours.

**Ordering Information**

EXAMPLE: DSX1 LED P7 40K T3M MVOLT SPA NLTAIR2 PIRHN DBBXD

Series	LEDs	Color temperature	Distribution	Voltage	Mounting	
DSX1 LED	Forward optics P1 P4 <sup>1</sup> P7 <sup>1</sup> P2 P5 <sup>1</sup> P8 P3 P6 <sup>1</sup> P9 <sup>1</sup> Rotated optics P10 <sup>2</sup> P12 <sup>2</sup> P11 <sup>2</sup> P13 <sup>2</sup>	30K 3000K 40K 4000K 50K 5000K	T1S Type I short (Automotive) T2S Type II short T2M Type II medium T3S Type III short T3M Type III medium T4M Type IV medium TFTM Forward throw medium	TSVS Type V very short <sup>1</sup> TSS Type V short <sup>1</sup> TSM Type V medium <sup>1</sup> TSW Type V wide <sup>1</sup> BLC Backlight control <sup>4</sup> LCCO Left corner cutoff <sup>4</sup> RCCO Right corner cutoff <sup>4</sup>	MVOLT <sup>5</sup> XVOLT (277V-480V) <sup>5,6,7</sup> 120 <sup>8</sup> 240 <sup>8</sup> 277 <sup>8</sup> 347 <sup>8</sup> 480 <sup>8</sup>	Shipped included SPA Square pole mounting RPA Round pole mounting <sup>9</sup> WBA Wall bracket <sup>1</sup> SPUMBA Square pole universal mounting adaptor <sup>11</sup> RPLUMBA Round pole universal mounting adaptor <sup>9</sup>

**Control options**

Shipped installed	Other options	Finish required
NITAIR2 iLight AIR generation 2 enabled <sup>12</sup>	HS House-side shield <sup>12</sup>	DBBXD Dark bronze
PIRHN Network, high/low motion/ambient sensor <sup>13</sup>	SF Single fuse (120, 277, 347V) <sup>8</sup>	DBLXD Black
PER NEMA twist-lock receptacle only (controls ordered separately) <sup>14</sup>	DF Double fuse (208, 240, 480V) <sup>8</sup>	DNAXD Natural aluminum
PER5 Five-pin receptacle only (controls ordered separately) <sup>14,15</sup>	L90 Left rotated optics <sup>1</sup>	DWHXD White
PER7 Seven-pin receptacle only (controls ordered separately) <sup>14,16</sup>	R90 Right rotated optics <sup>1</sup>	DBBXD Textured dark bronze
DMG 0-10v dimming wires pulled outside fixture (for use with external control, ordered separately) <sup>17</sup>	HA 50°C ambient operations <sup>1</sup>	DBLXD Textured black
DS Dual switching <sup>18,19</sup>	BAA Buy America(n) Act Compliant	DNATXD Textured natural aluminum
	Shipped separately	DWHGXD Textured white
	BS Bird spikes <sup>20</sup>	
	EGS External glare shield	



## RSXF1 LED Floodlight

**Specifications**

EPA (ft<sup>2</sup>@45°): 2.1 ft<sup>2</sup> (0.2 m<sup>2</sup>)

Length: 20.7" (52.6 cm)

Width: 13.3" (33.8 cm)

Height: 3.0" (7.6 cm) Main Body  
7.6" (19.3 cm) Arm

Weight (max): 31 lbs (14.1 kg)

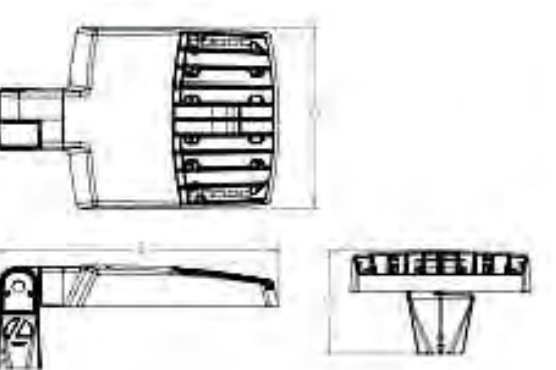

**Introduction**

The new RSXF LED Flood family delivers maximum value by providing significant energy savings, long life and outstanding photometric performance at an affordable price. The RSXF1 delivers 7,000 to 17,000 lumens allowing it to replace 70W to 400W HID floodlights.

The RSXF features an adjustable integral slipfitter that allows the luminaire to be mounted on a 2-3/8" OD tenon. Integral cover/wire box serves as an approved splice compartment allowing for fast, easy mounting and wiring without opening the electrical compartment. A yoke and other mounting configurations are available.

**Ordering Information**

EXAMPLE: RSXF1 LED P4 40K WFL MVOLT IS DBBXD

Series	Performance Package	Color Temperature	Distribution	Voltage	Mounting
RSXF1 LED	P1 P2 P3 P4	30K 3000K 40K 4000K 50K 5000K	AWFD Area Wide Flood WFL Wide Flood MFL Medium Flood NFL Narrow Flood SP Spot NSP Narrow Spot	MVOLT (120V-277V) <sup>1</sup> MVOLT (347V-480V) <sup>2</sup> XVOLT (277V-480V) <sup>1</sup> 120 <sup>3</sup> 277 <sup>3</sup> 240 <sup>3</sup> 480 <sup>3</sup>	IS Adjustable slipfitter (fits 2.1/8" OD tenon) <sup>4</sup> YKCG2 Yoke with 1/8-3/8" stud, 2 1/2" dia AASP Adjustable tilt arm square pole mounting <sup>5</sup> AARP Adjustable tilt arm round pole mounting <sup>5</sup> AANB Adjustable tilt arm with wall bracket <sup>5</sup> AANWC Adjustable tilt arm wall bracket and surface-mount base <sup>5</sup>

**Options**

Shipped Installed	Shipped Separately	Finish required
PE Photocell; button type <sup>6,7</sup>	SPUMBA Square pole universal mounting adaptor <sup>11</sup>	DBBXD Dark bronze
PEX Photocell; external thermostat, adjustable <sup>6</sup>	RPA Round pole mounting <sup>9</sup>	DBLXD Black
PER7 Seven-pin twist-lock receptacle only (see controls) <sup>14,15,16</sup>	WBA Wall bracket <sup>1</sup>	DNAXD Natural aluminum
CE34 Conductivity 3/4" (191) (8y 2)	SPUMBA Square pole universal mounting adaptor <sup>11</sup>	DWHXD White
CF Single fuse (120, 277, 347) <sup>8</sup>	RPLUMBA Round pole universal mounting adaptor <sup>9</sup>	DBBXD Textured dark bronze
DF Double fuse (208, 240, 480) <sup>8</sup>	HA 50°C ambient operations <sup>1</sup>	DBLXD Textured black
L90 Left rotated optics <sup>1</sup>	BAA Buy America(n) Act Compliant	DNATXD Textured natural aluminum
R90 Right rotated optics <sup>1</sup>	Shipped separately	DWHGXD Textured white
HA 50°C ambient operations <sup>1</sup>	BS Bird spikes <sup>20</sup>	
BAA Buy America(n) Act Compliant	EGS External glare shield	

REVISIONS	
A	
B	
C	
D	
E	

VERIFY SCALE BAR IS ONE INCH ON ORIGINAL DRAWING  
 0 1" IF NOT ONE INCH ON THIS SHEET, ADJUST SCALE(S) ACCORDINGLY

PROPOSED TRUCK YARD SITE PLAN FOR:  
**HSD TRUCKING**  
 8645 GARDEN HIGHWAY, SUTTER COUNTY  
 ATN: 25-090-029

**LAUGHLIN and SPENCE**  
 CIVIL ENGINEERS & SURVEYORS  
 1008 Live Oak Boulevard  
 Yuba City, California 95991  
 (530) 671-1008  
 fax (530) 671-0822



THESE PLANS ARE CONSIDERED "PRELIMINARY" OR "FOR REVIEW" UNLESS WET SIGNED AND SEALED BY THE ENGINEER. THEY SHALL NOT BE USED FOR CONSTRUCTION UNLESS STAMPED APPROVED BY THE LOCAL AGENCY.

Date	3-24-22
Scale	1"=40'
Drawn	JWS, BM
Job	217191
Sheet	

**P2**  
 Page 9 OF 9

**APPENDIX B**  
**AIR QUALITY AND GREENHOUSE GAS ANALYSIS**

# Draft Analysis of Impacts to Air Quality and Greenhouse Gas from Proposed Truck Yard

Yuba City, California

March 14, 2022

Prepared For:  
Money Dhami  
1728 Regency Way  
Yuba City, CA 95993

Prepared By:  
Environmental Permitting Specialists  
7068 Riverside Boulevard  
Sacramento, CA 95831  
*Contact: Ray Kapahi, Principal*  
*Tel: 916-687-8352*  
*Ray.Kapahi@gmail.com*

# TABLE OF CONTENTS

<b>SECTION 1: INTRODUCTION.....</b>	<b>3</b>
<b>SECTION 2: PROJECT EMISSIONS .....</b>	<b>6</b>
2.1 Construction Emissions	
2.2 Operational Emissions	
<b>SECTION 3: SIGNIFICANCE OF Project Emissions .....</b>	<b>11</b>
3.1 Significance Criteria	
3.2 Project Impacts	
<b>SECTION 4: REFERENCES.....</b>	<b>15</b>
<b>APPENDIX</b>	
1. CalEEMod Emissions Model Calculations for the Construction Phases	
2. Traffic Trip Analysis	

## SECTION 1: INTRODUCTION

Environmental Permitting Specialists (EPS) has prepared an analysis to evaluate impacts to air quality, greenhouse gas (GHG) and public health risks associated with the proposed truck yard in Sutter County. The proposed truck yard is located West of Garden Highway near Ashford Avenue in the rural part of Sutter County. The site is approximately 16 acres and would have 202 parking spaces (Figure 1). This analysis has been prepared in support of an environmental review being conducted by the Planning Department at Sutter County.

The project site is currently vacant with no structures on-site (Figure 1-2). The parking yard will be a self-serve type with no employees or attendants. It would operate 24 hours per day, 7 days per week. Trucks would travel from the yard to nearby arterial roads and highways such as Routes 99, 113 and I-5. While the yard would be open 365 days per year, an individual truck would only spend 4 to 5 days per month at the yard. The majority of the time, the trucks would be travelling outside the County and State and are involved in interstate shipping.

Construction at the site would involve minimal grading and site work as this site is level. This would be followed by paving. No demolition is required. Construction is expected to begin by the Summer of 2022 and would be completed in 60 days. The following impacts are evaluated:

Project Phase	Air Quality	Public Health	Greenhouse Gas
Construction	x		x
Operational (Occupancy)	x	x	x

The overall approach used in this analysis is to quantify the emission rates of regulated air pollutants for the construction and occupancy phases and then compare the emission rates with thresholds of significance established by the Feather River Air Quality Management District (FRAQMD). The project is considered to have potentially significant environmental impact if any of the emission rates exceed the thresholds of significance established by FRAQMD. The thresholds of significance are discussed in Section 3.

This report is divided into 4 sections. Immediately following this Introduction, the project emissions are discussed in Section 2. The Project impacts are discussed in Section 3. The report concludes with a discussion of the significance of the project's impacts on air quality, public health and GHG (Section 5). Technical details and calculations are provided in the Appendix.

Figure 1-1  
Vicinity Map

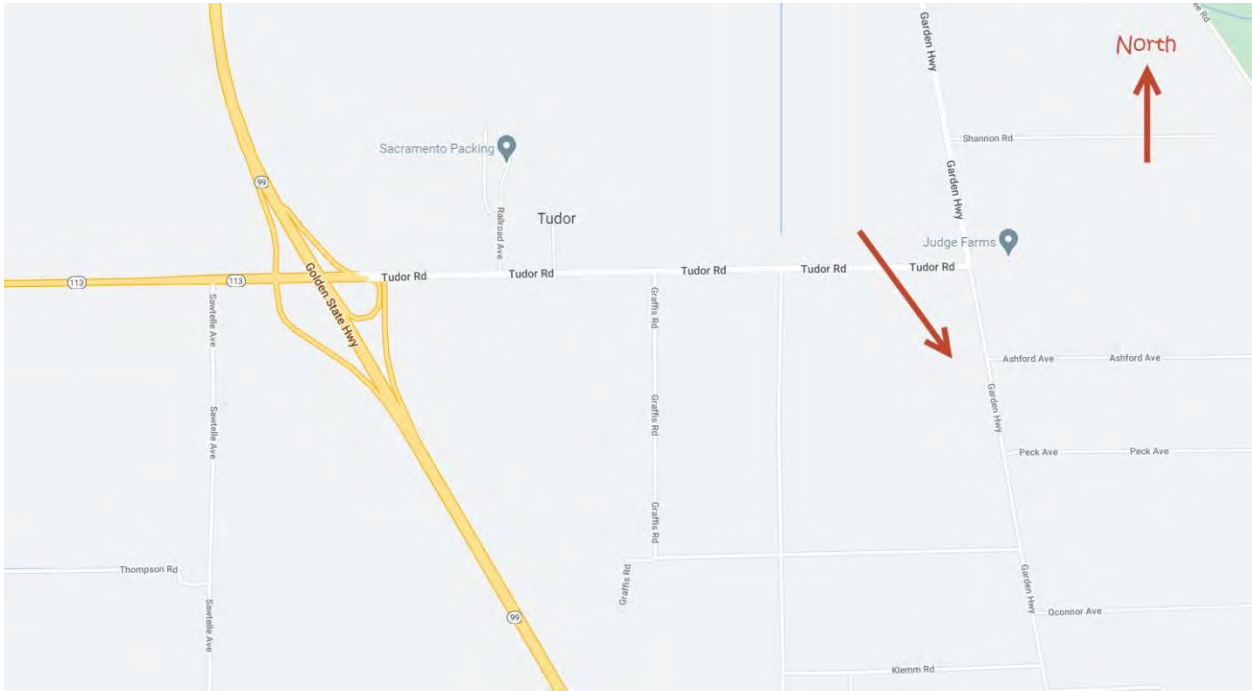
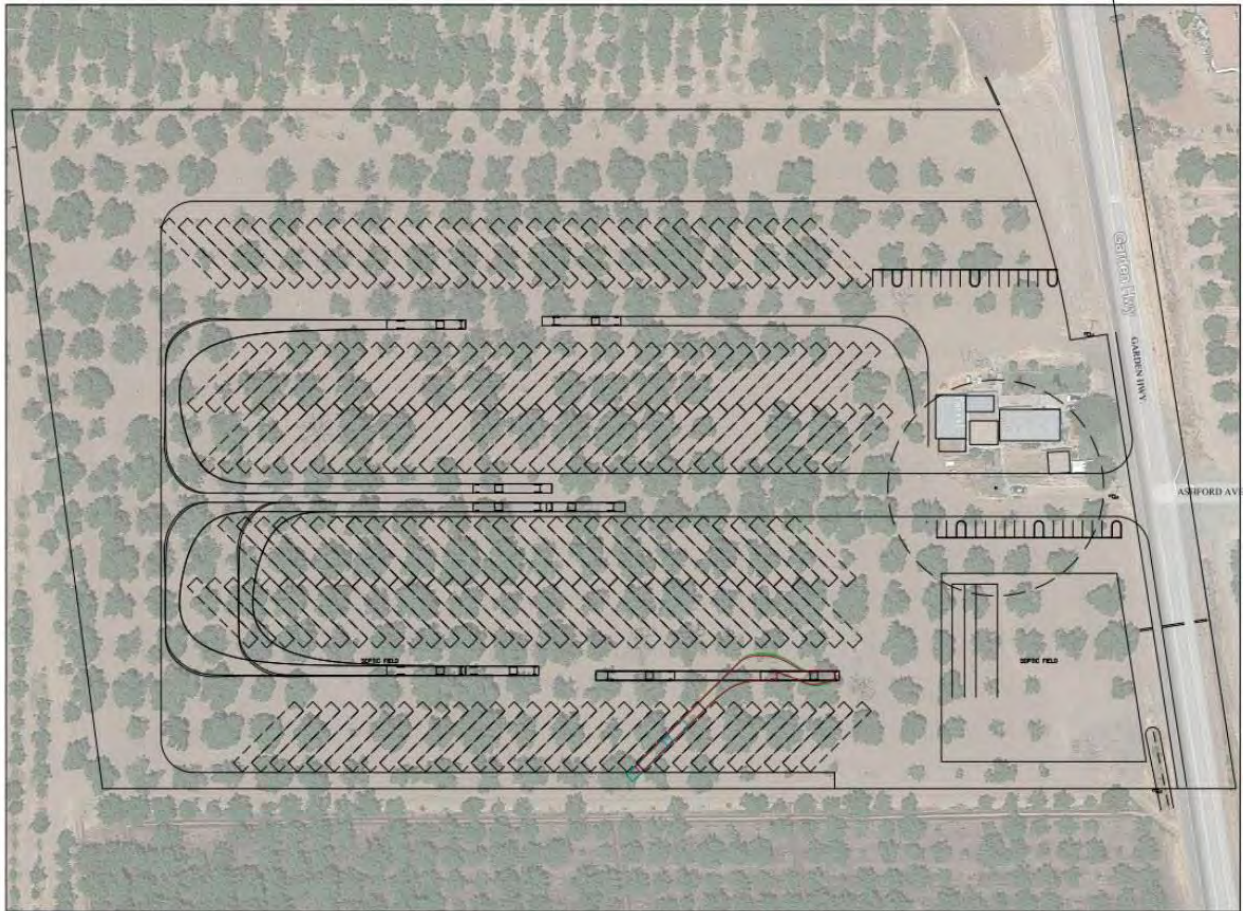

Figure 1-2  
Site Map



## SECTION 2: PROJECT EMISSIONS

The construction and operation of the parking yard would release a variety of emissions. These can be divided into three categories:

- A. Criteria air emissions
  - Oxides of nitrogen (NOx)
  - Carbon monoxide (CO)
  - Volatile organic compounds (VOCs)
  - Oxides of sulfur (SOx)
  - Fine particulate matter (PM-10)
  - Ultra-fine particulate matter (PM-2.5)
  
- B. Emissions of toxic air contaminants
  - Primarily diesel particulate matter (DPM, same as exhaust PM-10))
  
- C. Emissions of greenhouse gases
  - Carbon dioxide (CO<sub>2</sub>)
  - Methane (CH<sub>4</sub>)
  - Nitrous Oxide (N<sub>2</sub>O<sub>2</sub>)

### 2.1 Construction Emissions

As noted in the Introduction, construction would consist of site work, some minimal grading and paving. These activities would release fugitive dust from grading and site-work, exhaust emissions from construction equipment and VOC emissions from the asphaltic concrete.

The emission rates were calculated using the California Emissions Estimator Model (CalEEMod) developed by the California Air Pollution Control Officers Association. Version 2020.4.0 of this model was used to calculate the emissions. The results are summarized in Figures 2-1 and 2-2 are based on the development of 104 parking spaces rather than lot size.

**Figure 2-1  
Maximum Daily Emissions – Construction Phase**

	ROG	NOx	CO	SO2	Fugitive PM10	Exhaust PM10	PM10 Total	Fugitive PM2.5	Exhaust PM2.5	PM2.5 Total
Year	lb/day									
2022	3.9833	18.4197	8.8014	0.0213	14.0337	0.8196	14.8533	5.5254	0.7541	6.2794
Maximum	3.9833	18.4197	8.8014	0.0213	14.0337	0.8196	14.8533	5.5254	0.7541	6.2794

**Figure 2-2**  
**Maximum Daily GHG Emissions – Construction Phase**

Bio- CO2	NBio- CO2	Total CO2	CH4	N2O	CO2e
lb/day					
0.0000	2,064.9879	2,064.9879	0.6326	2.8400e-003	2,081.6482
0.0000	2,064.9879	2,064.9879	0.6326	2.8400e-003	2,081.6482

A copy of the CalEEMod emissions reports are provided in Appendix 1.

## 2.2 Operational Emissions

### Vehicular Emissions

Operating emissions consist of truck and light duty vehicle exhaust emissions and any fugitive road dust from vehicle travel on paved roads. Vehicle exhaust emissions were calculated using the Emissions Factor (EMFAC) model developed by the California Air Resources Board to assess mobile source emissions for each air basin, county or the whole state. EMFAC 2021 was used for vehicle emissions for calendar year 2022 and is based on an aggregate of all model years currently operating statewide. The EMFAC 2021 model provides emissions in terms of grams per mile for each vehicle category as well as emissions during truck idling in terms of grams per 8 hour day. An excerpt of the EMFAC 2021 model is shown in Figure 2-3.

**Figure 2-3**  
**Excerpt of EMFAC Model Output for Sutter County**

Source: EMFAC2021 (v1.0.1) Emission Rates											
Region Type: Statewide											
Region: California											
Calendar Year: 2022											
Season: Annual											
Vehicle Classification: EMFAC202x Categories											
Units: miles/day for CVMT and EVMT, trips/day for Trips, g/mile for RUNEX, PMBW and PMTW, g/trip for STREX, HOTSOAK and RUNLOSS, g/vehicle/day for IDLEX and DIURN. PH											
Region	CY	Veh Category	Model Year	Speed	Fuel	NOx_RUNEX	NOx_IDLEX	PM2.5_RUNEX	PM2.5_IDLEX	PM10_RUNEX	PM10_IDLEX
Statewide	2022	LDA	Aggregate	Aggregate	Gasoline	0.05398061	0	0.00138461	0	0.001505864	0
Statewide	2022	T6 Instate Tractor Class 6	Aggregate	Aggregate	Diesel	1.67187442	15.70238928	0.028147738	0.080828335	0.029420454	0.084483033

Daily and annual emissions were calculated as follows:

Daily Emissions in pounds =  $\frac{\text{Emission Factor (grams/mile)} \times \text{Miles Travelled per Day}}{454 \text{ grams/pound}}$

**Emissions of Fugitive Road Dust**

Emissions of fugitive road dust were estimated using data published by ARB “Entrained Road Travel, Paved Road Dust” (ARB 2018). Data are provided for each County. It is based on annual vehicle miles travelled and the amount of Average vehicle miles per day travelled are based on road dust that is entrained into the atmosphere. For 2018, 798 million miles were travelled (VMT) resulting in emissions of 55.74 tons of PM-10 from major roads. This equates to 0.00014 pounds of PM-10 emissions per VMT.

The traffic study completed by K. D. Anderson, Inc. indicated the following daily traffic volumes:

**Figure 2-3  
Estimate of Daily Vehicle Trips**

	HD Trucks	Light Duty Cars and Trucks
Daily Volume	154	231

A copy of the vehicle trip analysis is provided in Appendix 2. An estimate of daily emissions based on these trips is provided in Tables 2-1 and 2-2 for light duty vehicles and trucks respectively. An estimate of GHG emissions is included in these tables.

**Table 2-1**

**Emissions from Automobiles and Light Duty Trucks**

Pollutant	EF	Emissions		
	(g/mile)	(lbs/day)	(lbs/yr)	(tons/yr)
NOx	0.0540	0.27	16.5	0.008
PM-2.5				
Exhaust	0.0014	0.01	0.4	0.0002
Road Dust	2.10E-05	1.07E-04	6.40E-03	3.20E-06
Total	0.0014	0.0072	0.4291	0.0002
PM-10				
Exhaust	0.0015	0.0077	0.460	0.0002
Road Dust	1.40E-04	7.11E-04	4.26E-02	2.13E-05
Total	0.0016	0.0084	0.5024	0.0003
ROG	0.0128	0.07	3.9	0.002
SOx	0.0029	0.01	0.9	0.000
CO	0.8922	4.54	272.4	0.136
CO2(e)	298.3421	1518.00	91,080	45.540
<b>Notes</b>				
No. of Vehicles:	231	vehicles/day		
Trip Length:	10	miles		
Operating Days/yr:	60	days/yr		
Ratio PM-2.5/PM-10:	0.15	Ref: ARB Road Dust Speciation Profile #471		

**Table 2-2**

**Emissions from Heavy Duty Trucks**

Pollutant	EF	Emissions		
	(g/mile)	(lbs/day)	(lbs/yr)	(tons/yr)
NOx	1.6719	11.34	680.5	0.340
PM-2.5				
Exhaust	0.0281	0.19	11.5	0.0057
Road Dust	2.10E-05	1.42E-04	8.53E-03	4.26E-06
Total	0.0282	0.1911	11.4660	0.0057
PM-10				
Exhaust	0.0294	0.200	11.976	0.0060
Road Dust	0.0001	0.001	0.057	0.0000
Total	0.0296	0.201	12.0	0.0060
ROG	0.0598	0.41	24.4	0.012
SOx	0.0105	0.07	4.3	0.002
CO	0.1847	1.25	75.2	0.038
CO2(e)	1,168.0	7923.8	475,426	237.7
<b>Notes</b>				
No. of Vehicles:	154	vehicles/day		
Trip Length:	20	miles		
Operating Days/yr:	60	days/yr		
Ratio PM-2.5/PM-10:	0.15	Ref: ARB Road Dust Speciation Profile #471		

## SECTION 3: SIGNIFICANCE OF PROJECT IMPACTS

The emissions presented in Section 2 for criteria air pollutants are compared with mass emission thresholds established by the FRAQMD and Sutter County.

### 3.1 Significance Criteria

The significance criteria are summarized below.

FRAQMD MASS EMISSIONS THRESHOLDS OF SIGNIFICANCE			
	NO <sub>x</sub>	ROG	PM <sub>10</sub>
Construction	25ppd, not to exceed 4.5tpy <sup>a</sup>	25ppd, not to exceed 4.5tpy <sup>a</sup>	80ppd
Operation	25ppd	25ppd	80ppd

NOTES:  
a NO<sub>x</sub> and ROG construction emissions may be averaged over the life of the project, but may not exceed 4.5 tpy. tpy=tons per year; ppd=pounds per day

SOURCE: Feather River Air Quality Management District (FRAQMD), 2010. *Indirect Source Review Guidelines; Chapter 3: Thresholds of Significance*. June 7, 2020. Available at <https://www.fraqmd.org/files/658e76309/Chapter+3.pdf>. Accessed September 2, 2020.

In addition, Sutter County has established GHG pre-screening tables to simplify the determination of GHG impacts. See below.

1500-03-110 Transportation, Communication, and Utilities Use Types		
A. Aerial Services	1. Airports and Landing Strips 2. Heliports	Pre-Screened Out
B. Community Facilities and Services	1. Community Facilities and Services, Major 2. Community Facilities and Services, Intensive	Analyze Using CAP (Both Land Use Types)
C. Intermodal Transportation Services		Analyze Using CAP
D. Parking Facilities		Pre-Screened Out

For toxic air, the significance criteria are follows:

Cancer Risk: Maximum 10 cancers/million

Non-Cancer Hazard Index: Maximum 1.0

### 3.2 Project Impacts

The project's short-term operating emissions and a comparison with the significance thresholds are summarized in Table 3-1.

**Table 3-1  
Comparison of Daily Construction Emissions with Thresholds of Significance**

Pollutant	Emissions	Threshold of Significance	Impact Significant?
NOx	18.42	25	No
ROG	3.98	25	No
PM-10	14.85	80	No

The project's long-term operating emissions and a comparison with the significance thresholds are summarized in Table 3-2.

**Table 3-2  
Summary of Emissions of Criteria Air Pollutants**

Pollutant	Emissions (lbs/day)			Threshold of Significance	Impact Significant ?
	Autos	Trucks	Total		
NOx	0.2747	11.342	11.62	25	No
PM-2.5	0.0070	0.1911	0.20	No Threshold	N/A
PM-10	0.0077	0.2005	0.21	80	No
ROG	0.065	0.0653	0.13	25	No
SOx	0.015	0.0715	0.09	No Threshold	N/A
CO	4.540	1.253	5.79	No Threshold	N/A
CO2e (tons/yr)	45.5	237.7	283.3	Exempt	No

For toxic air pollutants, the main TAC is diesel exhaust particulate matter (DPM). DPM is regulated as a carcinogen by the FRAQMD and the California Air Resources Board. The emission rates of exhaust PM-10 are considered a surrogate for DPM. For the current project, annual on-site emission rates of exhaust PM-10 were estimated. These emissions occur during truck idling. As shown in Figure 2-3, Truck idle emissions are only 0.084 grams per 8 hour day or 0.0106 grams per hour. For the current analysis, each truck was assumed to idle 15 minutes<sup>1</sup>. For all 154 trucks, this equates to 2,310 minutes (38.5 hours) of idle time per day or 14,052.5 hours per year for all trucks based on a 365 day per year operating schedule.

Annual emissions of DPM are estimated as follows:

$$\text{Annual Emissions} = \frac{14,052.5 \text{ hrs/yr} \times 0.0106 \text{ grams/hr}}{454 \text{ grams/lb}} = 0.328 \text{ lbs/yr}$$

Given the very low level of DPM emissions, a detailed health risk assessment is not warranted. Therefore, a screening level risk analysis was completed. A screening level risk analysis provides a conservative estimate of potential health risks. A “cancer risk score” is calculated for various distances from the project site. If the cancer risk score is above 10 at the nearest home, then the risk is considered significant and then a more detailed health risks analysis is prepared.

The results of the screening level risk analysis are shown in Table 3-3. The cancer risk score is given for various distances (in meters). For example, the score is 7.58E-01 (0.758) for distances between 0 to 100 meters. For distances greater than 100 meters, the risk score is 1.89E-01 (0.189) or lower. These results indicate that exposure to DPM would not result in a significant impact to public health.

---

<sup>1</sup> This is a conservative estimate of idle time. State law limits idle time to a maximum of 5 minutes.

**Table 3-3**

**Results of Screening Level Risk Analysis**

A		B	C	D	E	F	G	H	
<b>Name</b>		<b>Prioritization Calculator</b>							
<b>Applicability</b>		Use to provide a Prioritization score based on the emission potency method. Entries required in yellow areas, output in gray areas.							
<i>Author or updater</i>		Ray Kapahi		<i>Last Update</i>		March 13, 2022			
<b>Facility:</b>		Dhami Truck Yard Garden Highway at Ashford Rd							
<b>ID#:</b>		Yuba City, CA							
<b>Project #:</b>									
<b>Unit and Process#</b>									
<b>Operating Hours hr/yr</b>		8,760.00							
<b>Receptor Proximity and Proximity Factors</b>		<b>Cancer Score</b>	<b>Chronic Score</b>	<b>Acute Score</b>	<b>Max Score</b>	Receptor proximity is in meters. Prioritization scores are calculated by multiplying the total scores summed below by the proximity factors. Record the Max score for your receptor distance. If the substance list for the unit is longer than the number of rows here or if there are multiple processes use additional worksheets and sum the totals of the Max Scores.			
<b>0 &lt; R &lt; 100</b>	<b>1.000</b>	7.58E-01	1.12E-03	0.00E+00	7.58E-01				
<b>100 ≤ R &lt; 250</b>	<b>0.250</b>	1.89E-01	2.81E-04	0.00E+00	1.89E-01				
<b>250 ≤ R &lt; 500</b>	<b>0.040</b>	3.03E-02	4.49E-05	0.00E+00	3.03E-02				
<b>500 ≤ R &lt; 1000</b>	<b>0.011</b>	8.33E-03	1.24E-05	0.00E+00	8.33E-03				
<b>1000 ≤ R &lt; 1500</b>	<b>0.003</b>	2.27E-03	3.37E-06	0.00E+00	2.27E-03				
<b>1500 ≤ R &lt; 2000</b>	<b>0.002</b>	1.52E-03	2.25E-06	0.00E+00	1.52E-03				
<b>2000 &lt; R</b>	<b>0.001</b>	7.58E-04	1.12E-06	0.00E+00	7.58E-04				
0		Enter the unit's CAS# of the substances emitted and their amounts.				Prioritization score for each substance generated below. Totals on last row.			
<b>Substance</b>		<b>CAS#</b>	<b>Annual Emissions (lbs/yr)</b>	<b>Maximum Hourly (lbs/hr)</b>	<b>Average Hourly (lbs/hr)</b>	<b>Cancer</b>	<b>Chronic</b>	<b>Acute</b>	
Diesel engine exhaust, particulate matter (Diesel PM)		9901	3.28E-01		3.74E-05	7.58E-01	1.12E-03	0.00E+00	
					0.00E+00	0.00E+00	0.00E+00	0.00E+00	
					0.00E+00	0.00E+00	0.00E+00	0.00E+00	
					0.00E+00	0.00E+00	0.00E+00	0.00E+00	
					0.00E+00	0.00E+00	0.00E+00	0.00E+00	

## SECTION 6: REFERENCES

CalEEMod (2020): California Emissions Estimator Model. Information available at:

<http://www.caleemod.com/>

CAPCOA (2008). CEQA and Climate Change: Evaluating and Addressing Greenhouse Gas Emissions from Projects Subject to CEQA. January 2008.

CARB Title 17 Section 95812 (c)(1).

CCAPCD (2021): Colusa County Air Pollution Control District Rules and Regulations. Available at:

<https://www.countyofcolusa.org/836/Rules-and-Regulations>

EPA (2009) Federal Register 56272-73, October 30, 2009

## APPENDIX 1

### Calculation of Emissions from Construction and Operational Phases

Dhami Tudor Road (1.3 acres) - Sutter County, Summer

**EMFAC Off-Model Adjustment Factors for Gasoline Light Duty Vehicle to Account for the SAFE Vehicle Rule Not Applied**

**Dhami Tudor Road (1.3 acres)**

**Sutter County, Summer**

**1.0 Project Characteristics**

**1.1 Land Usage**

Land Uses	Size	Metric	Lot Acreage	Floor Surface Area	Population
Parking Lot	202.00	Space	11.50	500,940.00	0

**1.2 Other Project Characteristics**

<b>Urbanization</b>	Rural	<b>Wind Speed (m/s)</b>	2.2	<b>Precipitation Freq (Days)</b>	61
<b>Climate Zone</b>	2	<b>Operational Year</b>		2022	
<b>Utility Company</b>	Pacific Gas and Electric Company				
<b>CO2 Intensity (lb/MWhr)</b>	203.98	<b>CH4 Intensity (lb/MWhr)</b>	0.033	<b>N2O Intensity (lb/MWhr)</b>	0.004

**1.3 User Entered Comments & Non-Default Data**

Project Characteristics -

Land Use - Lot size 5 acres

Construction Phase - No Demolition

Minimal Grading, No Trenchong, No Building Construction

Off-road Equipment - Minimal Grading

Off-road Equipment - Minimal grading required.

Off-road Equipment - Per site area

Off-road Equipment - Minimal site prepartion required.

Trips and VMT - Per project specifications

Grading - Max 5 acre to be graded and then use Chip Seal

Dhami Tudor Road (1.3 acres) - Sutter County, Summer

**EMFAC Off-Model Adjustment Factors for Gasoline Light Duty Vehicle to Account for the SAFE Vehicle Rule Not Applied**

Table Name	Column Name	Default Value	New Value
tblConstructionPhase	NumDays	30.00	23.00
tblConstructionPhase	NumDays	20.00	11.00
tblConstructionPhase	NumDays	10.00	22.00
tblConstructionPhase	PhaseEndDate	7/26/2022	7/15/2022
tblConstructionPhase	PhaseEndDate	8/23/2022	7/30/2022
tblConstructionPhase	PhaseEndDate	6/14/2022	6/30/2022
tblConstructionPhase	PhaseStartDate	7/27/2022	7/15/2022
tblGrading	AcresOfGrading	17.25	90.00
tblGrading	AcresOfGrading	8.25	15.00
tblLandUse	LandUseSquareFeet	80,800.00	500,940.00
tblLandUse	LotAcreage	1.82	11.50
tblOffRoadEquipment	OffRoadEquipmentUnitAmount	3.00	1.00
tblOffRoadEquipment	OffRoadEquipmentUnitAmount	4.00	1.00
tblOffRoadEquipment	OffRoadEquipmentUnitAmount	2.00	0.00
tblOffRoadEquipment	OffRoadEquipmentUnitAmount	2.00	0.00
tblOffRoadEquipment	OffRoadEquipmentUnitAmount	2.00	0.00
tblOffRoadEquipment	OffRoadEquipmentUnitAmount	2.00	0.00
tblOffRoadEquipment	OffRoadEquipmentUnitAmount	2.00	1.00
tblOffRoadEquipment	OffRoadEquipmentUnitAmount	2.00	1.00
tblOffRoadEquipment	UsageHours	8.00	6.00
tblOffRoadEquipment	UsageHours	8.00	6.00
tblOffRoadEquipment	UsageHours	8.00	6.00
tblOffRoadEquipment	UsageHours	8.00	6.00
tblOffRoadEquipment	UsageHours	8.00	6.00
tblOffRoadEquipment	UsageHours	8.00	6.00
tblOffRoadEquipment	UsageHours	8.00	6.00
tblProjectCharacteristics	UrbanizationLevel	Urban	Rural

**2.0 Emissions Summary**



Dhami Tudor Road (1.3 acres) - Sutter County, Summer

**EMFAC Off-Model Adjustment Factors for Gasoline Light Duty Vehicle to Account for the SAFE Vehicle Rule Not Applied**

**2.2 Overall Operational**

**Unmitigated Operational**

	ROG	NOx	CO	SO2	Fugitive PM10	Exhaust PM10	PM10 Total	Fugitive PM2.5	Exhaust PM2.5	PM2.5 Total	Bio- CO2	NBio- CO2	Total CO2	CH4	N2O	CO2e
Category	lb/day										lb/day					
Area	0.2748	1.9000e-004	0.0207	0.0000		7.0000e-005	7.0000e-005		7.0000e-005	7.0000e-005		0.0442	0.0442	1.2000e-004		0.0471
Energy	0.0000	0.0000	0.0000	0.0000		0.0000	0.0000		0.0000	0.0000		0.0000	0.0000	0.0000	0.0000	0.0000
Mobile	0.0000	0.0000	0.0000	0.0000	0.0000	0.0000	0.0000	0.0000	0.0000	0.0000		0.0000	0.0000	0.0000	0.0000	0.0000
<b>Total</b>	<b>0.2748</b>	<b>1.9000e-004</b>	<b>0.0207</b>	<b>0.0000</b>	<b>0.0000</b>	<b>7.0000e-005</b>	<b>7.0000e-005</b>	<b>0.0000</b>	<b>7.0000e-005</b>	<b>7.0000e-005</b>		<b>0.0442</b>	<b>0.0442</b>	<b>1.2000e-004</b>	<b>0.0000</b>	<b>0.0471</b>

**Mitigated Operational**

	ROG	NOx	CO	SO2	Fugitive PM10	Exhaust PM10	PM10 Total	Fugitive PM2.5	Exhaust PM2.5	PM2.5 Total	Bio- CO2	NBio- CO2	Total CO2	CH4	N2O	CO2e
Category	lb/day										lb/day					
Area	0.2748	1.9000e-004	0.0207	0.0000		7.0000e-005	7.0000e-005		7.0000e-005	7.0000e-005		0.0442	0.0442	1.2000e-004		0.0471
Energy	0.0000	0.0000	0.0000	0.0000		0.0000	0.0000		0.0000	0.0000		0.0000	0.0000	0.0000	0.0000	0.0000
Mobile	0.0000	0.0000	0.0000	0.0000	0.0000	0.0000	0.0000	0.0000	0.0000	0.0000		0.0000	0.0000	0.0000	0.0000	0.0000
<b>Total</b>	<b>0.2748</b>	<b>1.9000e-004</b>	<b>0.0207</b>	<b>0.0000</b>	<b>0.0000</b>	<b>7.0000e-005</b>	<b>7.0000e-005</b>	<b>0.0000</b>	<b>7.0000e-005</b>	<b>7.0000e-005</b>		<b>0.0442</b>	<b>0.0442</b>	<b>1.2000e-004</b>	<b>0.0000</b>	<b>0.0471</b>

Dhami Tudor Road (1.3 acres) - Sutter County, Summer

**EMFAC Off-Model Adjustment Factors for Gasoline Light Duty Vehicle to Account for the SAFE Vehicle Rule Not Applied**

	ROG	NOx	CO	SO2	Fugitive PM10	Exhaust PM10	PM10 Total	Fugitive PM2.5	Exhaust PM2.5	PM2.5 Total	Bio- CO2	NBio-CO2	Total CO2	CH4	N2O	CO2e
Percent Reduction	0.00	0.00	0.00	0.00	0.00	0.00	0.00	0.00	0.00	0.00	0.00	0.00	0.00	0.00	0.00	0.00

**3.0 Construction Detail**

**Construction Phase**

Phase Number	Phase Name	Phase Type	Start Date	End Date	Num Days Week	Num Days	Phase Description
1	Site Preparation	Site Preparation	6/1/2022	6/30/2022	5	22	
2	Grading	Grading	6/15/2022	7/15/2022	5	23	
3	Paving	Paving	7/15/2022	7/30/2022	5	11	

**Acres of Grading (Site Preparation Phase): 15**

**Acres of Grading (Grading Phase): 90**

**Acres of Paving: 11.5**

**Residential Indoor: 0; Residential Outdoor: 0; Non-Residential Indoor: 0; Non-Residential Outdoor: 0; Striped Parking Area: 0 (Architectural Coating – sqft)**

**OffRoad Equipment**

Phase Name	Offroad Equipment Type	Amount	Usage Hours	Horse Power	Load Factor
Site Preparation	Rubber Tired Dozers	1	6.00	247	0.40
Site Preparation	Tractors/Loaders/Backhoes	1	6.00	97	0.37
Grading	Excavators	0	8.00	158	0.38
Grading	Graders	1	6.00	187	0.41
Grading	Rubber Tired Dozers	1	6.00	247	0.40
Grading	Tractors/Loaders/Backhoes	0	8.00	97	0.37
Grading	Scrapers	0	8.00	367	0.48
Paving	Pavers	0	8.00	130	0.42

Dhami Tudor Road (1.3 acres) - Sutter County, Summer

**EMFAC Off-Model Adjustment Factors for Gasoline Light Duty Vehicle to Account for the SAFE Vehicle Rule Not Applied**

Paving	Paving Equipment	1	6.00	132	0.36
Paving	Rollers	1	6.00	80	0.38

**Trips and VMT**

Phase Name	Offroad Equipment Count	Worker Trip Number	Vendor Trip Number	Hauling Trip Number	Worker Trip Length	Vendor Trip Length	Hauling Trip Length	Worker Vehicle Class	Vendor Vehicle Class	Hauling Vehicle Class
Site Preparation	2	5.00	0.00	0.00	16.80	6.60	20.00	LD_Mix	HDT_Mix	HHDT
Grading	2	5.00	0.00	0.00	16.80	6.60	20.00	LD_Mix	HDT_Mix	HHDT
Paving	2	5.00	0.00	0.00	16.80	6.60	20.00	LD_Mix	HDT_Mix	HHDT

**3.1 Mitigation Measures Construction**

**3.2 Site Preparation - 2022**

**Unmitigated Construction On-Site**

	ROG	NOx	CO	SO2	Fugitive PM10	Exhaust PM10	PM10 Total	Fugitive PM2.5	Exhaust PM2.5	PM2.5 Total	Bio- CO2	NBio- CO2	Total CO2	CH4	N2O	CO2e
Category	lb/day										lb/day					
Fugitive Dust					5.2396	0.0000	5.2396	2.5607	0.0000	2.5607			0.0000			0.0000
Off-Road	0.7514	7.8520	4.3650	8.7300e-003		0.3806	0.3806		0.3502	0.3502		846.2057	846.2057	0.2737		853.0477
<b>Total</b>	<b>0.7514</b>	<b>7.8520</b>	<b>4.3650</b>	<b>8.7300e-003</b>	<b>5.2396</b>	<b>0.3806</b>	<b>5.6202</b>	<b>2.5607</b>	<b>0.3502</b>	<b>2.9109</b>		<b>846.2057</b>	<b>846.2057</b>	<b>0.2737</b>		<b>853.0477</b>

Dhami Tudor Road (1.3 acres) - Sutter County, Summer

**EMFAC Off-Model Adjustment Factors for Gasoline Light Duty Vehicle to Account for the SAFE Vehicle Rule Not Applied**

**3.2 Site Preparation - 2022**

**Unmitigated Construction Off-Site**

	ROG	NOx	CO	SO2	Fugitive PM10	Exhaust PM10	PM10 Total	Fugitive PM2.5	Exhaust PM2.5	PM2.5 Total	Bio- CO2	NBio- CO2	Total CO2	CH4	N2O	CO2e
Category	lb/day										lb/day					
Hauling	0.0000	0.0000	0.0000	0.0000	0.0000	0.0000	0.0000	0.0000	0.0000	0.0000		0.0000	0.0000	0.0000	0.0000	0.0000
Vendor	0.0000	0.0000	0.0000	0.0000	0.0000	0.0000	0.0000	0.0000	0.0000	0.0000		0.0000	0.0000	0.0000	0.0000	0.0000
Worker	0.0234	0.0147	0.2293	5.8000e-004	0.0639	3.0000e-004	0.0642	0.0169	2.8000e-004	0.0172		58.7732	58.7732	1.3800e-003	1.4200e-003	59.2304
<b>Total</b>	<b>0.0234</b>	<b>0.0147</b>	<b>0.2293</b>	<b>5.8000e-004</b>	<b>0.0639</b>	<b>3.0000e-004</b>	<b>0.0642</b>	<b>0.0169</b>	<b>2.8000e-004</b>	<b>0.0172</b>		<b>58.7732</b>	<b>58.7732</b>	<b>1.3800e-003</b>	<b>1.4200e-003</b>	<b>59.2304</b>

**Mitigated Construction On-Site**

	ROG	NOx	CO	SO2	Fugitive PM10	Exhaust PM10	PM10 Total	Fugitive PM2.5	Exhaust PM2.5	PM2.5 Total	Bio- CO2	NBio- CO2	Total CO2	CH4	N2O	CO2e
Category	lb/day										lb/day					
Fugitive Dust					5.2396	0.0000	5.2396	2.5607	0.0000	2.5607			0.0000			0.0000
Off-Road	0.7514	7.8520	4.3650	8.7300e-003		0.3806	0.3806		0.3502	0.3502	0.0000	846.2057	846.2057	0.2737		853.0477
<b>Total</b>	<b>0.7514</b>	<b>7.8520</b>	<b>4.3650</b>	<b>8.7300e-003</b>	<b>5.2396</b>	<b>0.3806</b>	<b>5.6202</b>	<b>2.5607</b>	<b>0.3502</b>	<b>2.9109</b>	<b>0.0000</b>	<b>846.2057</b>	<b>846.2057</b>	<b>0.2737</b>		<b>853.0477</b>

Dhami Tudor Road (1.3 acres) - Sutter County, Summer

**EMFAC Off-Model Adjustment Factors for Gasoline Light Duty Vehicle to Account for the SAFE Vehicle Rule Not Applied**

**3.2 Site Preparation - 2022**

**Mitigated Construction Off-Site**

	ROG	NOx	CO	SO2	Fugitive PM10	Exhaust PM10	PM10 Total	Fugitive PM2.5	Exhaust PM2.5	PM2.5 Total	Bio- CO2	NBio- CO2	Total CO2	CH4	N2O	CO2e
Category	lb/day										lb/day					
Hauling	0.0000	0.0000	0.0000	0.0000	0.0000	0.0000	0.0000	0.0000	0.0000	0.0000		0.0000	0.0000	0.0000	0.0000	0.0000
Vendor	0.0000	0.0000	0.0000	0.0000	0.0000	0.0000	0.0000	0.0000	0.0000	0.0000		0.0000	0.0000	0.0000	0.0000	0.0000
Worker	0.0234	0.0147	0.2293	5.8000e-004	0.0639	3.0000e-004	0.0642	0.0169	2.8000e-004	0.0172		58.7732	58.7732	1.3800e-003	1.4200e-003	59.2304
<b>Total</b>	<b>0.0234</b>	<b>0.0147</b>	<b>0.2293</b>	<b>5.8000e-004</b>	<b>0.0639</b>	<b>3.0000e-004</b>	<b>0.0642</b>	<b>0.0169</b>	<b>2.8000e-004</b>	<b>0.0172</b>		<b>58.7732</b>	<b>58.7732</b>	<b>1.3800e-003</b>	<b>1.4200e-003</b>	<b>59.2304</b>

**3.3 Grading - 2022**

**Unmitigated Construction On-Site**

	ROG	NOx	CO	SO2	Fugitive PM10	Exhaust PM10	PM10 Total	Fugitive PM2.5	Exhaust PM2.5	PM2.5 Total	Bio- CO2	NBio- CO2	Total CO2	CH4	N2O	CO2e
Category	lb/day										lb/day					
Fugitive Dust					8.6664	0.0000	8.6664	2.9308	0.0000	2.9308			0.0000			0.0000
Off-Road	0.9391	10.5384	3.9778	0.0114		0.4384	0.4384		0.4034	0.4034		1,101.2357	1,101.2357	0.3562		1,110.1398
<b>Total</b>	<b>0.9391</b>	<b>10.5384</b>	<b>3.9778</b>	<b>0.0114</b>	<b>8.6664</b>	<b>0.4384</b>	<b>9.1048</b>	<b>2.9308</b>	<b>0.4034</b>	<b>3.3341</b>		<b>1,101.2357</b>	<b>1,101.2357</b>	<b>0.3562</b>		<b>1,110.1398</b>

Dhami Tudor Road (1.3 acres) - Sutter County, Summer

**EMFAC Off-Model Adjustment Factors for Gasoline Light Duty Vehicle to Account for the SAFE Vehicle Rule Not Applied**

**3.3 Grading - 2022**

**Unmitigated Construction Off-Site**

	ROG	NOx	CO	SO2	Fugitive PM10	Exhaust PM10	PM10 Total	Fugitive PM2.5	Exhaust PM2.5	PM2.5 Total	Bio- CO2	NBio- CO2	Total CO2	CH4	N2O	CO2e
Category	lb/day										lb/day					
Hauling	0.0000	0.0000	0.0000	0.0000	0.0000	0.0000	0.0000	0.0000	0.0000	0.0000		0.0000	0.0000	0.0000	0.0000	0.0000
Vendor	0.0000	0.0000	0.0000	0.0000	0.0000	0.0000	0.0000	0.0000	0.0000	0.0000		0.0000	0.0000	0.0000	0.0000	0.0000
Worker	0.0234	0.0147	0.2293	5.8000e-004	0.0639	3.0000e-004	0.0642	0.0169	2.8000e-004	0.0172		58.7732	58.7732	1.3800e-003	1.4200e-003	59.2304
<b>Total</b>	<b>0.0234</b>	<b>0.0147</b>	<b>0.2293</b>	<b>5.8000e-004</b>	<b>0.0639</b>	<b>3.0000e-004</b>	<b>0.0642</b>	<b>0.0169</b>	<b>2.8000e-004</b>	<b>0.0172</b>		<b>58.7732</b>	<b>58.7732</b>	<b>1.3800e-003</b>	<b>1.4200e-003</b>	<b>59.2304</b>

**Mitigated Construction On-Site**

	ROG	NOx	CO	SO2	Fugitive PM10	Exhaust PM10	PM10 Total	Fugitive PM2.5	Exhaust PM2.5	PM2.5 Total	Bio- CO2	NBio- CO2	Total CO2	CH4	N2O	CO2e
Category	lb/day										lb/day					
Fugitive Dust					8.6664	0.0000	8.6664	2.9308	0.0000	2.9308			0.0000			0.0000
Off-Road	0.9391	10.5384	3.9778	0.0114		0.4384	0.4384		0.4034	0.4034	0.0000	1,101.2357	1,101.2357	0.3562		1,110.1398
<b>Total</b>	<b>0.9391</b>	<b>10.5384</b>	<b>3.9778</b>	<b>0.0114</b>	<b>8.6664</b>	<b>0.4384</b>	<b>9.1048</b>	<b>2.9308</b>	<b>0.4034</b>	<b>3.3341</b>	<b>0.0000</b>	<b>1,101.2357</b>	<b>1,101.2357</b>	<b>0.3562</b>		<b>1,110.1398</b>

Dhami Tudor Road (1.3 acres) - Sutter County, Summer

**EMFAC Off-Model Adjustment Factors for Gasoline Light Duty Vehicle to Account for the SAFE Vehicle Rule Not Applied**

**3.3 Grading - 2022**

**Mitigated Construction Off-Site**

	ROG	NOx	CO	SO2	Fugitive PM10	Exhaust PM10	PM10 Total	Fugitive PM2.5	Exhaust PM2.5	PM2.5 Total	Bio- CO2	NBio- CO2	Total CO2	CH4	N2O	CO2e
Category	lb/day										lb/day					
Hauling	0.0000	0.0000	0.0000	0.0000	0.0000	0.0000	0.0000	0.0000	0.0000	0.0000		0.0000	0.0000	0.0000	0.0000	0.0000
Vendor	0.0000	0.0000	0.0000	0.0000	0.0000	0.0000	0.0000	0.0000	0.0000	0.0000		0.0000	0.0000	0.0000	0.0000	0.0000
Worker	0.0234	0.0147	0.2293	5.8000e-004	0.0639	3.0000e-004	0.0642	0.0169	2.8000e-004	0.0172		58.7732	58.7732	1.3800e-003	1.4200e-003	59.2304
<b>Total</b>	<b>0.0234</b>	<b>0.0147</b>	<b>0.2293</b>	<b>5.8000e-004</b>	<b>0.0639</b>	<b>3.0000e-004</b>	<b>0.0642</b>	<b>0.0169</b>	<b>2.8000e-004</b>	<b>0.0172</b>		<b>58.7732</b>	<b>58.7732</b>	<b>1.3800e-003</b>	<b>1.4200e-003</b>	<b>59.2304</b>

**3.4 Paving - 2022**

**Unmitigated Construction On-Site**

	ROG	NOx	CO	SO2	Fugitive PM10	Exhaust PM10	PM10 Total	Fugitive PM2.5	Exhaust PM2.5	PM2.5 Total	Bio- CO2	NBio- CO2	Total CO2	CH4	N2O	CO2e
Category	lb/day										lb/day					
Off-Road	0.2584	2.5977	3.3048	5.0200e-003		0.1382	0.1382		0.1271	0.1271		486.4292	486.4292	0.1573		490.3622
Paving	2.7391					0.0000	0.0000		0.0000	0.0000			0.0000			0.0000
<b>Total</b>	<b>2.9975</b>	<b>2.5977</b>	<b>3.3048</b>	<b>5.0200e-003</b>		<b>0.1382</b>	<b>0.1382</b>		<b>0.1271</b>	<b>0.1271</b>		<b>486.4292</b>	<b>486.4292</b>	<b>0.1573</b>		<b>490.3622</b>

Dhami Tudor Road (1.3 acres) - Sutter County, Summer

**EMFAC Off-Model Adjustment Factors for Gasoline Light Duty Vehicle to Account for the SAFE Vehicle Rule Not Applied**

**3.4 Paving - 2022**

**Unmitigated Construction Off-Site**

	ROG	NOx	CO	SO2	Fugitive PM10	Exhaust PM10	PM10 Total	Fugitive PM2.5	Exhaust PM2.5	PM2.5 Total	Bio- CO2	NBio- CO2	Total CO2	CH4	N2O	CO2e
Category	lb/day										lb/day					
Hauling	0.0000	0.0000	0.0000	0.0000	0.0000	0.0000	0.0000	0.0000	0.0000	0.0000		0.0000	0.0000	0.0000	0.0000	0.0000
Vendor	0.0000	0.0000	0.0000	0.0000	0.0000	0.0000	0.0000	0.0000	0.0000	0.0000		0.0000	0.0000	0.0000	0.0000	0.0000
Worker	0.0234	0.0147	0.2293	5.8000e-004	0.0639	3.0000e-004	0.0642	0.0169	2.8000e-004	0.0172		58.7732	58.7732	1.3800e-003	1.4200e-003	59.2304
<b>Total</b>	<b>0.0234</b>	<b>0.0147</b>	<b>0.2293</b>	<b>5.8000e-004</b>	<b>0.0639</b>	<b>3.0000e-004</b>	<b>0.0642</b>	<b>0.0169</b>	<b>2.8000e-004</b>	<b>0.0172</b>		<b>58.7732</b>	<b>58.7732</b>	<b>1.3800e-003</b>	<b>1.4200e-003</b>	<b>59.2304</b>

**Mitigated Construction On-Site**

	ROG	NOx	CO	SO2	Fugitive PM10	Exhaust PM10	PM10 Total	Fugitive PM2.5	Exhaust PM2.5	PM2.5 Total	Bio- CO2	NBio- CO2	Total CO2	CH4	N2O	CO2e
Category	lb/day										lb/day					
Off-Road	0.2584	2.5977	3.3048	5.0200e-003		0.1382	0.1382		0.1271	0.1271	0.0000	486.4292	486.4292	0.1573		490.3622
Paving	2.7391					0.0000	0.0000		0.0000	0.0000			0.0000			0.0000
<b>Total</b>	<b>2.9975</b>	<b>2.5977</b>	<b>3.3048</b>	<b>5.0200e-003</b>		<b>0.1382</b>	<b>0.1382</b>		<b>0.1271</b>	<b>0.1271</b>	<b>0.0000</b>	<b>486.4292</b>	<b>486.4292</b>	<b>0.1573</b>		<b>490.3622</b>

Dhami Tudor Road (1.3 acres) - Sutter County, Summer

**EMFAC Off-Model Adjustment Factors for Gasoline Light Duty Vehicle to Account for the SAFE Vehicle Rule Not Applied**

**3.4 Paving - 2022**

**Mitigated Construction Off-Site**

	ROG	NOx	CO	SO2	Fugitive PM10	Exhaust PM10	PM10 Total	Fugitive PM2.5	Exhaust PM2.5	PM2.5 Total	Bio- CO2	NBio- CO2	Total CO2	CH4	N2O	CO2e
Category	lb/day										lb/day					
Hauling	0.0000	0.0000	0.0000	0.0000	0.0000	0.0000	0.0000	0.0000	0.0000	0.0000		0.0000	0.0000	0.0000	0.0000	0.0000
Vendor	0.0000	0.0000	0.0000	0.0000	0.0000	0.0000	0.0000	0.0000	0.0000	0.0000		0.0000	0.0000	0.0000	0.0000	0.0000
Worker	0.0234	0.0147	0.2293	5.8000e-004	0.0639	3.0000e-004	0.0642	0.0169	2.8000e-004	0.0172		58.7732	58.7732	1.3800e-003	1.4200e-003	59.2304
<b>Total</b>	<b>0.0234</b>	<b>0.0147</b>	<b>0.2293</b>	<b>5.8000e-004</b>	<b>0.0639</b>	<b>3.0000e-004</b>	<b>0.0642</b>	<b>0.0169</b>	<b>2.8000e-004</b>	<b>0.0172</b>		<b>58.7732</b>	<b>58.7732</b>	<b>1.3800e-003</b>	<b>1.4200e-003</b>	<b>59.2304</b>

Dhami Tudor Road (1.3 acres) - Sutter County, Summer

**EMFAC Off-Model Adjustment Factors for Gasoline Light Duty Vehicle to Account for the SAFE Vehicle Rule Not Applied**

**4.0 Operational Detail - Mobile**

**4.1 Mitigation Measures Mobile**

	ROG	NOx	CO	SO2	Fugitive PM10	Exhaust PM10	PM10 Total	Fugitive PM2.5	Exhaust PM2.5	PM2.5 Total	Bio- CO2	NBio- CO2	Total CO2	CH4	N2O	CO2e
Category	lb/day										lb/day					
Mitigated	0.0000	0.0000	0.0000	0.0000	0.0000	0.0000	0.0000	0.0000	0.0000	0.0000		0.0000	0.0000	0.0000	0.0000	0.0000
Unmitigated	0.0000	0.0000	0.0000	0.0000	0.0000	0.0000	0.0000	0.0000	0.0000	0.0000		0.0000	0.0000	0.0000	0.0000	0.0000

**4.2 Trip Summary Information**

Land Use	Average Daily Trip Rate			Unmitigated	Mitigated
	Weekday	Saturday	Sunday	Annual VMT	Annual VMT
Parking Lot	0.00	0.00	0.00		
Total	0.00	0.00	0.00		

**4.3 Trip Type Information**

Land Use	Miles			Trip %			Trip Purpose %		
	H-W or C-W	H-S or C-C	H-O or C-NW	H-W or C-W	H-S or C-C	H-O or C-NW	Primary	Diverted	Pass-by
Parking Lot	14.70	6.60	6.60	0.00	0.00	0.00	0	0	0

**4.4 Fleet Mix**

Land Use	LDA	LDT1	LDT2	MDV	LHD1	LHD2	MHD	HHD	OBUS	UBUS	MCY	SBUS	MH
Parking Lot	0.491726	0.046816	0.174288	0.165875	0.042775	0.009340	0.015448	0.021765	0.000361	0.000000	0.026038	0.001433	0.004134

Dhami Tudor Road (1.3 acres) - Sutter County, Summer

**EMFAC Off-Model Adjustment Factors for Gasoline Light Duty Vehicle to Account for the SAFE Vehicle Rule Not Applied**

**5.0 Energy Detail**

Historical Energy Use: N

**5.1 Mitigation Measures Energy**

	ROG	NOx	CO	SO2	Fugitive PM10	Exhaust PM10	PM10 Total	Fugitive PM2.5	Exhaust PM2.5	PM2.5 Total	Bio- CO2	NBio- CO2	Total CO2	CH4	N2O	CO2e	
Category	lb/day										lb/day						
NaturalGas Mitigated	0.0000	0.0000	0.0000	0.0000		0.0000	0.0000		0.0000	0.0000		0.0000	0.0000	0.0000	0.0000	0.0000	0.0000
NaturalGas Unmitigated	0.0000	0.0000	0.0000	0.0000		0.0000	0.0000		0.0000	0.0000		0.0000	0.0000	0.0000	0.0000	0.0000	0.0000

**5.2 Energy by Land Use - NaturalGas**

**Unmitigated**

	NaturalGas Use	ROG	NOx	CO	SO2	Fugitive PM10	Exhaust PM10	PM10 Total	Fugitive PM2.5	Exhaust PM2.5	PM2.5 Total	Bio- CO2	NBio- CO2	Total CO2	CH4	N2O	CO2e
Land Use	kBTU/yr	lb/day										lb/day					
Parking Lot	0	0.0000	0.0000	0.0000	0.0000		0.0000	0.0000		0.0000	0.0000		0.0000	0.0000	0.0000	0.0000	0.0000
<b>Total</b>		<b>0.0000</b>	<b>0.0000</b>	<b>0.0000</b>	<b>0.0000</b>		<b>0.0000</b>	<b>0.0000</b>		<b>0.0000</b>	<b>0.0000</b>		<b>0.0000</b>	<b>0.0000</b>	<b>0.0000</b>	<b>0.0000</b>	<b>0.0000</b>

Dhami Tudor Road (1.3 acres) - Sutter County, Summer

**EMFAC Off-Model Adjustment Factors for Gasoline Light Duty Vehicle to Account for the SAFE Vehicle Rule Not Applied**

**5.2 Energy by Land Use - NaturalGas**

Mitigated

	NaturalGas Use	ROG	NOx	CO	SO2	Fugitive PM10	Exhaust PM10	PM10 Total	Fugitive PM2.5	Exhaust PM2.5	PM2.5 Total	Bio- CO2	NBio- CO2	Total CO2	CH4	N2O	CO2e
Land Use	kBTU/yr	lb/day										lb/day					
Parking Lot	0	0.0000	0.0000	0.0000	0.0000		0.0000	0.0000		0.0000	0.0000		0.0000	0.0000	0.0000	0.0000	0.0000
<b>Total</b>		<b>0.0000</b>	<b>0.0000</b>	<b>0.0000</b>	<b>0.0000</b>		<b>0.0000</b>	<b>0.0000</b>		<b>0.0000</b>	<b>0.0000</b>		<b>0.0000</b>	<b>0.0000</b>	<b>0.0000</b>	<b>0.0000</b>	<b>0.0000</b>

**6.0 Area Detail**

**6.1 Mitigation Measures Area**

	ROG	NOx	CO	SO2	Fugitive PM10	Exhaust PM10	PM10 Total	Fugitive PM2.5	Exhaust PM2.5	PM2.5 Total	Bio- CO2	NBio- CO2	Total CO2	CH4	N2O	CO2e
Category	lb/day										lb/day					
Mitigated	0.2748	1.9000e-004	0.0207	0.0000		7.0000e-005	7.0000e-005		7.0000e-005	7.0000e-005		0.0442	0.0442	1.2000e-004		0.0471
Unmitigated	0.2748	1.9000e-004	0.0207	0.0000		7.0000e-005	7.0000e-005		7.0000e-005	7.0000e-005		0.0442	0.0442	1.2000e-004		0.0471

Dhami Tudor Road (1.3 acres) - Sutter County, Summer

**EMFAC Off-Model Adjustment Factors for Gasoline Light Duty Vehicle to Account for the SAFE Vehicle Rule Not Applied**

**6.2 Area by SubCategory**

**Unmitigated**

	ROG	NOx	CO	SO2	Fugitive PM10	Exhaust PM10	PM10 Total	Fugitive PM2.5	Exhaust PM2.5	PM2.5 Total	Bio- CO2	NBio- CO2	Total CO2	CH4	N2O	CO2e
SubCategory	lb/day										lb/day					
Architectural Coating	0.0954					0.0000	0.0000		0.0000	0.0000			0.0000			0.0000
Consumer Products	0.1774					0.0000	0.0000		0.0000	0.0000			0.0000			0.0000
Landscaping	1.9200e-003	1.9000e-004	0.0207	0.0000		7.0000e-005	7.0000e-005		7.0000e-005	7.0000e-005		0.0442	0.0442	1.2000e-004		0.0471
<b>Total</b>	<b>0.2748</b>	<b>1.9000e-004</b>	<b>0.0207</b>	<b>0.0000</b>		<b>7.0000e-005</b>	<b>7.0000e-005</b>		<b>7.0000e-005</b>	<b>7.0000e-005</b>		<b>0.0442</b>	<b>0.0442</b>	<b>1.2000e-004</b>		<b>0.0471</b>

Dhami Tudor Road (1.3 acres) - Sutter County, Summer

**EMFAC Off-Model Adjustment Factors for Gasoline Light Duty Vehicle to Account for the SAFE Vehicle Rule Not Applied**

**6.2 Area by SubCategory**

Mitigated

	ROG	NOx	CO	SO2	Fugitive PM10	Exhaust PM10	PM10 Total	Fugitive PM2.5	Exhaust PM2.5	PM2.5 Total	Bio- CO2	NBio- CO2	Total CO2	CH4	N2O	CO2e
SubCategory	lb/day										lb/day					
Architectural Coating	0.0954					0.0000	0.0000		0.0000	0.0000			0.0000			0.0000
Consumer Products	0.1774					0.0000	0.0000		0.0000	0.0000			0.0000			0.0000
Landscaping	1.9200e-003	1.9000e-004	0.0207	0.0000		7.0000e-005	7.0000e-005		7.0000e-005	7.0000e-005		0.0442	0.0442	1.2000e-004		0.0471
<b>Total</b>	<b>0.2748</b>	<b>1.9000e-004</b>	<b>0.0207</b>	<b>0.0000</b>		<b>7.0000e-005</b>	<b>7.0000e-005</b>		<b>7.0000e-005</b>	<b>7.0000e-005</b>		<b>0.0442</b>	<b>0.0442</b>	<b>1.2000e-004</b>		<b>0.0471</b>

**7.0 Water Detail**

**7.1 Mitigation Measures Water**

Dhami Tudor Road (1.3 acres) - Sutter County, Summer

**EMFAC Off-Model Adjustment Factors for Gasoline Light Duty Vehicle to Account for the SAFE Vehicle Rule Not Applied**

**8.0 Waste Detail**

---

**8.1 Mitigation Measures Waste**

**9.0 Operational Offroad**

---

Equipment Type	Number	Hours/Day	Days/Year	Horse Power	Load Factor	Fuel Type
----------------	--------	-----------	-----------	-------------	-------------	-----------

**10.0 Stationary Equipment**

---

**Fire Pumps and Emergency Generators**

Equipment Type	Number	Hours/Day	Hours/Year	Horse Power	Load Factor	Fuel Type
----------------	--------	-----------	------------	-------------	-------------	-----------

**Boilers**

Equipment Type	Number	Heat Input/Day	Heat Input/Year	Boiler Rating	Fuel Type
----------------	--------	----------------	-----------------	---------------	-----------

**User Defined Equipment**

Equipment Type	Number
----------------	--------

**11.0 Vegetation**

---

## APPENDIX 2

### Trip Generation Report

Source: K. D. Anderson, Inc. (March 04, 2022)

**CEQA TRANSPORTATION IMPACT ANALYSIS AND  
TRAFFIC OPERATIONAL ASSESSMENT**

**FOR**

**THREE TRUCK PARKING FACILITIES ON  
TUDOR ROAD AND GARDEN HIGHWAY**

Sutter County, California

*Prepared For:*

**JOVAN ORCHARDS**

1728 Regency Way  
Yuba City, CA 95993

*Prepared By:*

**KD Anderson & Associates, Inc.**

3853 Taylor Road, Suite G  
Loomis, CA 95650  
(916) 660-1555

March 4, 2022

4180-01

Jovan Tudor Road Truck Parking.rpt

*KD Anderson & Associates, Inc.*

Transportation Engineers

**CEQA TRANSPORTATION IMPACT ANALYSIS AND TRAFFIC OPERATIONAL  
ASSESSMENT FOR THREE TRUCK PARKING FACILITIES ON  
TUDOR ROAD AND GARDEN HIGHWAY**  
Sutter County, California

**TABLE OF CONTENTS**

---

---

<b>INTRODUCTION.....</b>	<b>1</b>
<b>BACKGROUND INFORMATION.....</b>	<b>2</b>
Existing Facilities / Background Traffic Operating Conditions .....	2
Regulations / Standards .....	4
<b>DESCRIPTION OF PROPOSED PROJECTS.....</b>	<b>8</b>
Three Sites.....	8
Project Travel Characteristics.....	8
<b>PROJECT IMPACTS UNDER CEQA.....</b>	<b>10</b>
Vehicle Miles Traveled (VMT) Impact.....	10
Impacts to Other Transportation Modes.....	13
Safety Impacts to Caltrans Facilities .....	13
<b>TRAFFIC OPERATIONAL ANALYSIS.....</b>	<b>14</b>
Effects based on Daily Traffic Volumes and Level of Service .....	14
Effects Based on Intersection LOS.....	16
Traffic Signal Warrants .....	16
Site access .....	16
<b>CUMULATIVE TRAFFIC OPERATIONS.....</b>	<b>19</b>
Background .....	19
<b>APPENDIX.....</b>	<b>22</b>

**KDA**

**CEQA TRANSPORTATION IMPACT ANALYSIS AND TRAFFIC OPERATIONAL  
ASSESSMENT FOR THREE TRUCK PARKING FACILITIES ON  
TUDOR ROAD AND GARDEN HIGHWAY**  
Sutter County, California

**INTRODUCTION**

This report addresses the CEQA transportation impacts and traffic operational effects of three separate Truck Parking Facilities proposed in the Tudor Industrial / Commercial area near the Tudor Road / Garden Highway intersection in Sutter County, CA. The proposed projects will occupy a total of 20± acres and provide parking for up to 325 truck-trailer combinations. Figure 1 locates the projects and Figures 2 thru 4 are the project site plans. Figures are located in the appendix.

The analysis which follows addresses specific questions from Sutter County following their review of the three projects that are addressed in a CEQA Transportation Impact analysis and a focused Traffic Analysis Report (TAR). These questions include:

1. What types of trucks will be using the site, and if STAA trucks are anticipated, is the route to and from SR 99 legally adequate for these vehicles?
2. At what time and in what number will trucks be leaving and arriving at the proposed facilities daily?
3. What are the effects on mainline Tudor Road and Garden Highway traffic created by project's truck traffic, and are improvements to the site access beyond those proposed with each site needed?
4. What are the effects of the three projects on adjoining State Route 99?
5. What are the cumulative effects of all three projects operating together?
6. Do the project's effects comply with Sutter County General Plan policies and zoning code requirements for access improvements?
7. What are the impacts of these projects under the California Environmental Quality Act (CEQA) on regional Vehicle Miles Traveled (VMT)?

## BACKGROUND INFORMATION

### Existing Facilities / Background Traffic Operating Conditions

The text which follows describes the circulation system in the area of these projects.

**State Route 99 (SR 99).** SR 99 is a generally four-lane conventional highway with a continuous center striped median. However, access at the Tudor Road (State Route 113) junction is provided at grade separated interchange. The most recent traffic volume counts available from the California Department of Transportation (Caltrans) indicate that in 2019 SR 99 carried an Average Annual Daily Traffic (AADT) volume of 16,700 vehicles per day south of Tudor Road and 19,950 AADT to the north. Trucks comprise about 10% of the daily volume. The posted speed limit is 65 mph.

**Tudor Road and State Route 113 (SR 113).** Tudor Road extends easterly from a point near the Sutter Bypass across SR 99 to Garden Highway. The segment between George Washington Blvd and SR 99 is also State Route 113. In the area east of SR 99 Tudor Road is designated a Rural Major Collector in Figure 6-1 of the Sutter County General Plan Mobility Element and is a two-lane facility with 12-foot travel lanes and 8-foot shoulders. Caltrans reports that State Route 113 (SR 113) carried 4,500 AADT in 2019 west of the SR 99 interchange, and of that total, trucks comprise 7% of the daily volume. While no 24 counts are available, based on peak hour traffic counts conducted for this study the daily volume is estimated to be 1,400 vehicles per day between SR 99 and Garden Highway, and 4% of that volume would be heavy trucks. Tudor Road and SR 113 are designated a Terminal Road for trucks permitted under the Surface Transportation Authority Act (STAA). That designation extends across the Garden Highway intersection into the adjoining industrial use.

**Garden Highway.** Garden Highway is a Rural Major Collector that extends north along the Feather River from a connection to SR 99 via Wilson Road into Yuba City. The portion of Garden Highway north of Wilson Road to Tudor Road is a two-lane facility with 12-foot travel lanes and 8-foot shoulders. The rural prima facie 55 mph speed limit applies.

The Sutter County General Plan EIR identified 4,280 vehicles per day on Garden Highway north of Tudor Road to O'Banion Road. While 24-hr counts are not available south of Tudor Road, Caltrans traffic counts at the SR 99 / Wilson Road interchange on March 5, 2020 indicated that the volume east of SR 99 from 6:00 a.m. to 9:00 p.m. was 1,025 vehicles, and the daily traffic volume would be estimated to be about 1,100 vehicles per day based on that data. Of the observed volume, 38 vehicles were heavy trucks, or about 4% of the total volume.

That daily volume estimate would be consistent with the results of peak hour traffic counts at the Garden Highway / Tudor Road intersection completed for this study. A combined total of 219 vehicles used Garden Highway south of Tudor Road in the two peak hours, and the estimated daily volume is 1,400 vehicles per day. A total of 24 heavy trucks and 475 total vehicles were observed on Garden Highway south of Tudor Road during the four hours that were counted. Trucks were 5% of that total.

Sutter County is in the process of applying for STAA terminal route designation for the portion of Garden Highway from the Tudor Road intersection south to Wilson Road and the westerly along Wilson Road to SR 99. Preliminary response from Caltrans suggest that improvements would be needed to allow STAA trucks onto Wilson Road.

**SR 99 / Tudor Road (SR 113) interchange.** This grade separated interchange is configured as a diamond for SB ramps traffic and a partial clover-leaf for the NB SR 99 ramps. The SB ramps intersection has a two-lane approach controlled by a stop sign, and the off-ramp extends for 1,200 feet to the gore point on mainline SR 99. The eastbound approach has a separate right turn lane, and the SB on ramp is 2,000 feet long. The westbound Tudor Road approach has a separate left turn lane that is 390 feet long. The intersection is illuminated by streetlights on two corners. The NB ramps intersection is controlled by a stop sign on the single lane off ramp, and the ramp extends for 1,500 feet to mainline SR 99. The eastbound approach has a separate right turn lane onto the loop to NB SR 99. The westbound approach has separated right turn lane that extends through the intersection to a direct connection ramp onto NB SR 99. The on-ramp continues for 1,600 feet beyond Tudor Road to the mainline connection. There are no sidewalks in the vicinity of the interchange, but full-width shoulders extend across the structure. The intersection and ramps are illuminated.

Caltrans also publishes traffic count data for interchange ramps, and current daily traffic volumes are noted in Table 1. As indicated, the volumes on the ramps leading to and from the project (i.e., NB SR 99 off ramp, WB on ramp to NB SR 99 and SB SR 99 on - off ramps are all very low, (i.e., < 500 vehicles per day). While the SB off ramp carries more total traffic, nearly all of that volume turns right onto WB SR 113.

Direction	Ramp	Annual Average Daily Traffic (AADT)		
		2016	2017	2019
NB	Off to Tudor Road	230	228	265
	On from WB Tudor Road	220	-	203
	On from EB SR 113	1,580	1,405	1,429
SB	Off to Tudor Road / SR 113	2,100	1,909	1,965
	On from Tudor Road	400	404	459

**SR 99 / Wilson Road Intersection.** The Wilson Road intersection on SR 99 is controlled by a traffic signal. Separate left turn lanes are provided on SR 99 in both directions, and a northbound right turn lane onto Wilson Road is available. The eastbound Wilson Road approach is configured with a separate left turn lane and combined thru+right turn lane. The westbound Wilson Road approach has dual left turn lanes and combined thru+right turn lane. While crosswalks are not marked, the intersection has pedestrian indications and push buttons one each corner, and accessible ramps are available. The intersection is illuminated.

**Tudor Road / Garden Highway intersection.** The intersection is controlled by an all-way stop, and auxiliary turn lanes are available. The southbound approach has separate left turn and right turn lanes, and the right turn lane is outside of the stop control (i.e., yield). The northbound approach has a separate 200 foot long left turn lane. The westbound and eastbound Tudor Road approaches are single lanes. There are no sidewalks at the intersection, and no crosswalks are marked. The intersection is not illuminated.

**Peak Hour Traffic Volumes.** New a.m. and p.m. peak hour traffic counts at study area intersections are presented in Figure 5 (trucks only) and Figure 6 (all vehicles).

## **Regulations / Standards**

### **State of California**

**California Environmental Quality Act (CEQA) - SB 743.** With the adoption and 2020 implementation of SB 743, CEQA analysis of transportation impacts has moved from analysis of motorist delay based on Level of Service to consideration of a project's contribution to global climate change as expressed in terms of Vehicle Miles Traveled (VMT). While capacity analysis and Level of Service can still be considered by local agencies in addressing General Plan consistency, Level of Service is no longer a CEQA topic.

**State of California Department of Transportation (Caltrans).** Caltrans has jurisdiction over state highways. Caltrans' policy documents and analysis guidelines provide direction for transportation impact analysis.

**Highway Design Manual, 7<sup>th</sup> Edition (HDM).** The HDM establishes uniform policies and procedures to carry out the state highway design functions of the California Department of Transportation. The HDM establishes uniform policies and procedures to carry out the state highway design functions of the Department. It is neither intended as, nor does it establish, a legal standard for these functions. The standards, procedures, and requirements established and discussed herein are for the information and guidance of the officers and employees of the Department. Many of the instructions given herein are subject to amendment as conditions and experience warrant. Special situations may call for deviation from policies and procedures, subject to Division of Design approval, or such other approval as may be specifically provided for in the text of the HDM.

**Truck Turning Requirements.** Large trucks (53-foot trailers) are allowed on mainline SR 113 and Tudor Road under the Surface Transportation Authorization Act (STAA), but such vehicles are not permitted on intersecting Sutter County roads unless specifically designated for their use by Caltrans and the local agency (i.e., Sutter County) through evaluation of truck turning requirements. Private access anticipating trucks of this classification, as is typically the case for long haul operations, must also have access that can accommodate those vehicles.

**Sutter County General Plan Mobility Element.** These policies of the General Plan address the issues associated with the three projects.

M 2.4 Intersection and Driveway Spacing. Maximize intersection and driveway spacing on roadways. Driveway encroachments shall be minimized in accordance with the County’s improvement standards. (M 2-B)

M 2.5 Level of Service on County Roads. Develop and manage the County roadway segments and intersections to maintain LOS D or better during peak hour, and LOS C or better at all other times. Adjust for seasonality. These standards shall apply to all County roadway segments and intersections, unless otherwise addressed in an adopted specific plan or community plan. (M 2-C/M 2-D)

M 2.6 Mitigation by New Development. Require new development projects to analyze their local traffic impacts and to construct and implement the improvements necessary to fully mitigate their local impacts to traffic capacity, structural sections, and intersection geometrics. (M 2-E)

M 2.7 Regional Improvements. Require new development projects to analyze traffic impacts on the regional transportation system (i.e., facilities that provide regional connectivity to the new development) and require a fair share contribution to regional transportation improvements. (M 2-F)

The General Plan includes roadway segment LOS thresholds based on daily volumes, as noted in Table 2. The “rural road” thresholds are applicable to Tudor Road and Garden Highway.

<b>TABLE 2 SUTTER COUNTY GENERAL PLAN ROADWAY LEVELS OF SERVICE THRESHOLDS</b>			
<b>Roadway</b>	<b>LOS C</b>	<b>LOS D</b>	<b>LOS E</b>
Rural – Two-Lane	7,000 – 10,600	10,600 – 16,300	16,400 – 25,200
Urban – Three Lane	15,330 – 17,520	17,250 – 19,700	19,700 – 21,900
Urban – Five Lane	30,660 – 35,040	35,040 – 39,420	39,420 – 43,800
Expressway – Four Lane	29,100 – 41,800	41,801 – 53,500	53,501 – 59,500
Freeway – Four Lane	33,700 – 48,400	48,401 – 60,000	60,001 – 67,400
Freeway – Six Lane	51,800 – 73,900	73,901 – 90,900	90,901 – 101,800
Source: Sutter County General Plan DEIR – Traffic Table 6.14.6			

**Sutter County Zoning Code.** The project falls under Zoning Category 3. General Truck Yards, Large. Section 1500-05-030 E. 3. e., deals with facility access and traffic study requirements.

**3. General Truck Yards, Large**

a. In addition to other noticing requirements, upon receipt of an application for a new or modified General Truck Yard, Large, notice shall be provided to all property owners of record, within one-half (1/2) mile of the proposed project property boundaries advising an application has been received, providing a summary of the application and the location where project documents can be reviewed.



- b. General Truck Yards, Large, shall comply with the applicable requirements of Table 1500 07-3 (Commercial and Employment Design Checklist).
- c. General truck Yards, Large, may only be established in the Agriculture District when located immediately adjacent to a State Highway or a designated T or S-route (STAA).
- d. Lighting shall be provided consistent with Table 1500-07-3 (Commercial and Employment Design Checklist). Light pole and fixture height shall not exceed twenty-five (25) feet. Truck parking areas shall incorporate motion activated lighting that shall not spill onto adjoining properties. A photometric plan, prepared by an appropriately licensed design professional, shall be submitted at the time of application demonstrating compliance with this requirement.
- e. Facility access shall incorporate acceleration and deceleration lanes, the criteria for which is determined by completion of a traffic study prepared to recognized engineering standards, including County Improvement Standards that shall also determine any additional needed traffic related improvements. No vehicle shall be permitted to obstruct or back onto a public roadway. Facilities shall be designed so that trucks entering and exiting yards are not required to cross the road center line into opposing traffic. The traffic study shall be submitted at the time application is made to the Development Services Planning Division for the proposed use.
- f. Facilities located along a State Highway shall comply with the California Department of Transportation standards for roads, freeway entrances, sight distance and turning radius.
- g. Driveways shall be a minimum of forty (40) feet in width measured at the public right-of way or as deemed necessary by the Road Commissioner. Driveways shall be designed to allow trucks to enter and exit a facility without entering into opposing lanes of traffic.
- h. When proposed, access gates shall be setback a minimum of sixty-five (65) feet, or a sufficient distance, from the public right-of-way to allow trucks with trailers to completely exit the roadway when gates are closed.
- i. All maneuvering and parking areas for automobiles, trucks and trailers shall be located onsite and shall be paved and maintained consistent with Article 20. No parking or maneuvering for parking shall occur in a public road right-of-way. Wheel stops shall be provided for both automobile and truck parking areas to protect fencing, landscaping, structures and adjacent properties. The County may require operators to re-surface deteriorated asphalt areas and such work shall be completed within 180-days of the County making a request or by a mutually agreed time as approved by the Director. At his or her discretion, the Director may require the installation of wheel washing facilities or other measures necessary to eliminate impacts to the County road system.
- j. 1. When located outside a designated floodplain, permanent bathroom facilities (not portable toilets) shall be established onsite and shall be accessible during hours of operation and shall not be visible from the public right of way. Bathroom facilities shall include, at a minimum, a flushing toilet and a handwashing station and shall be serviced, as needed, on a regular basis. Bathrooms shall be provided at a minimum ratio of one (1) restroom per twenty-five (25) trucks or as otherwise determined by the Director."
2. When located in a designated floodplain, portable trailer mounted bathroom facilities may be established onsite and shall be accessible during hours of operation and shall not be visible from the public right of way. Bathroom facilities shall include, at a minimum, a toilet and handwashing station. Facilities shall be serviced, as needed, on a regular basis. The County may require an operator to document through a contract, or other means deemed sufficient, that bathroom facilities are being properly maintained. Bathrooms shall be provided at a minimum ratio of one (1) restroom per twenty-five (25) trucks or as otherwise determined by the Director.
- k. The minimum usable sewage disposal area shall be barricaded or have access physically restricted to prevent vehicles from driving or parking over it.
- l. A drainage plan, consistent with the County Improvement Standards, shall be submitted at the time application is made, demonstrating runoff resulting from site development will not adversely impact

surrounding property owners, or public rights-of-way. Drainage from parking areas shall utilize best available technology to minimize pollution and shall comply with State law.

m. Materials including truck parts, tires and related items, shall be contained inside a building, and in accordance with applicable State law. If a General Truck Yard, Large, proposes to conduct onsite repairs, such work shall occur within a building approved for said work. This requirement shall not apply to windshield, wiper, or truck headlight replacement work. A maximum of two inoperable trucks may be kept onsite for rebuilding or parts and shall be contained in a designated area, surfaced with concrete and designed to contain spilled fluids, and shall be located so as not to be visible from a public right of way or neighboring properties.

n. Truck and/or trailer maintenance, repair, and proper handling and disposal of hazardous materials shall comply with the requirements of the Development Services Department and applicable State law.

o. Facilities shall be screened from public view, roadways and adjoining, non-employment zoned, land through concrete masonry unit walls or chain-link fencing with privacy slats, having a minimum privacy rating of 90 percent or greater, and landscaping. All walls, fencing and landscaping shall be continuously maintained, and the Director may require replacement to damaged items.

p. Fifty-five (55) gallon trash waste receptacles, or equivalent, shall be provided at a minimum ratio of one (1) receptacle per five (5) trucks and shall be conveniently located in the truck/trailer parking area to facilitate their use. The County may allow other means of trash collection and control as appropriate.

q. Truck engine idling shall occur consistent with State law and compliance with this requirement shall be included as a project condition.

r. The operation of Transportation refrigeration units shall occur consistent with California Code of Regulations, Title 13, Division 3, Chapter 9, Article 8 commencing at Section 2477 or as amended.

s. At the time application is made, a plan shall be submitted demonstrating how undeveloped areas shall be maintained to prevent the creation of dust, erosion and shall not become a health hazard or create a public nuisance.

t. The County will consider as part of its review, indirect sources of traffic, noise and pollution, such as service trucks and passenger vehicles visiting facilities.

u. The County will consider requiring permanent onsite landscape setback buffers from existing adjacent residences, to be maintained by the property owner, to the extent feasible, for new or expanded facilities.

## DESCRIPTION OF PROPOSED PROJECTS

### Three Sites

This assessment addresses three separate truck parking sites that are summarized in Table 3 and were identified in Figure 1, and Figures 2-4.

#	Location	Acres $\pm$	Truck / Trailer Parking Spaces
1	848 Tudor Road	1.5	19
2	Garden Highway @ Ashford Avenue	11.5	202
3	Garden Highway @ Peck Avenue	7.0	104
	Total	20.0	325

### Project Travel Characteristics

**Type of Operation.** The operational characteristics of the project have been identified in terms of the amount of truck and automobile activity and the time periods of that travel. Typically, trucking operations fall into two categories: “Long haul” or “Local Distribution or Agricultural Harvesting / Processing Support”. For long haul trucks the typical routine sends drivers away from the site for extended periods of time. On a typical weeklong haul, most trucks return to the site on Friday and leave early Sunday or Monday, and most drivers try to operate outside peak traffic hours. Trips to the east coast can take longer. During the week some trucks may come and go for inspection or maintenance or if the drivers have to come home during the week. Alternatively, local based trucking typically leaves the site each weekday and returns that afternoon /evening. In both cases, a driver would travel by automobile to and from the site before beginning or ending his trips. Some of the truck drivers would park their personal auto at the site and others would be dropped off.

**Trip Generation.** This project’s trip generation was estimated based on available resources and our understanding of the characteristics of these uses. You have indicated that this site will be used by long haul truckers.

Long haul truck trip generation rates were developed from 24-hr truck traffic counts at a large (440 spaces) truck parking area in Yuba City. That site generated 334 total truck trips (143 in and 191 out) on a Thursday, or 7.6 daily truck trips per 10 spaces. It was assumed that drivers would generate automobile trips at the same time that trucks entered and exited and that ½ of the drivers would be dropped off / picked up.

Alternatively, for local trucks it would be assumed that all would move to and from the site each day, or 20 daily truck trips per 10 spaces. Typically, much local truck activity begins in the morning before the typical commute hour, and trucks return outside of the p.m. peak hour. For this analysis

we have assumed that 1/3 of the local trucks will travel to and from the site during peak hour, and that 1/2 of the drivers will be dropped off / picked up.

Assuming the truck at each site are all long haul the projects result in the daily and peak hour trip generation forecasts presented in the attached Tables A thru C in the appendix. As shown below in Table 4, all together, the three sites could generate 248 daily truck trips (i.e., 1/2 inbound and 1/2 outbound), and each day 373 automobile trips would be expected, for a total of 621 daily trips by vehicles of all types.

<b>TABLE 4 TRIP GENERATION ESTIMATES</b>					
#	Location	Spaces	Trips		
			Truck	Auto	Total
<i>Peak Hours</i>					
1	848 Tudor Road	19	1	2	3
2	Garden Highway @ Ashford Rd	202	11	17	28
3	Garden Highway @ Peck Rd	104	6	9	15
	All three sites	325	18	28	46
<i>Daily</i>					
1	848 Tudor Road	19	15	22	37
2	Garden Highway @ Ashford Rd	202	154	231	385
3	Garden Highway @ Peck Rd	104	79	120	199
	All three sites	325	248	373	621

**Trip Distribution.** Long haul trucks in the area typically follow routes along I-5, SR 99 or I-80, and SR 99 would be used to reach these routes. This analysis assumes that truck traffic is split 50% north of SR 99 and 50% on SR 99 to the south.

Automobile trips would generally be made between truck parking and the residences of drivers. In this case, the distribution of these trips would be based on the distribution of residences in the south Sutter County / north Sacramento County region. This analysis assumes 55% north on SR 99, 10% north on Garden Highway, 10% west on SR 113 and 25% south on SR 99.

**Traffic Assignments.** Caltrans has determined that an STAA Terminal route designation can be extended south on Garden Highway from the current Tudor Road terminus to the southern project access. The designation will not extend beyond the access to Wilson Road. Therefor all truck traffic has been assumed to use Tudor Road to the SR 99 interchange. The individual assignments of trucks and total vehicles for each of the three site is presented in the appendix. The cumulative truck traffic associated with all three projects is presented in Figure 7, while the cumulative total for all vehicles (i.e., automobiles and trucks) of all three projects is shown in Figure 8.

## PROJECT IMPACTS UNDER CEQA

The purpose of this analysis is to identify potential transportation impacts under the requirements of the California Environmental Quality Act (CEQA) as well as traffic operational effects as they relate to the introduction of project automobile and truck traffic on state highways. CEQA impacts relating to Vehicle Miles Traveled (VMT) with regular operation of the project has been discussed within the context of screening criteria presented in Governors' Office of Planning and Research (OPR) CEQA guidance. A traffic operations analysis was also conducted to identify the project's effects on state highway safety and with regards to Sutter County General Plan policies.

### Vehicle Miles Traveled (VMT) Impact

SB 743 requires the Governor's Office of Planning and Research (OPR) to identify new metrics for identifying and mitigating transportation impacts within CEQA. For land use projects, OPR identified Vehicle Miles Traveled (VMT) per capita, VMT per employee, and net VMT as new metrics for transportation analysis. The CEQA Guidelines state that lead agencies, such as Sutter County, may establish "thresholds of significance" to assist with the determination of significant impacts of a project. The CEQA Guidelines generally state that projects that decrease VMT can be assumed to have a less than significant transportation impact. The CEQA Guidelines do not provide any specific criteria on how to determine what level of project VMT would be considered a significant impact.

The extent to which VMT analysis is applicable to this project has been considered from several perspectives is discussed in the materials which follow.

**Vehicle Types.** OPR guidance notes that CEQA VMT analysis is intended to focus on passenger vehicles.

Proposed Section 15064.3, subdivision (a), states, "For the purposes of this section, 'vehicle miles traveled' refers to the amount and distance of automobile travel attributable to a project." Here, the term "automobile" refers to on-road passenger vehicles, specifically cars and light trucks.

OPR guidance allows Heavy-duty truck VMT to be included for modeling convenience and ease of calculation (for example, where models or data provide combined auto and heavy truck VMT).

**Methods and Significance Criteria.** The OPR *Technical Advisory* provides general direction regarding the methods to be employed and significance criteria to evaluate VMT impacts, absent policies adopted by local agencies. The directive addresses several aspects of VMT impact analysis, and is organized as follows:

- **Screening Criteria:** Screening criteria are intended to quickly identify when a project should be expected to cause a less-than-significant VMT impact without conducting a detailed study.
- **Significance Thresholds:** Significance thresholds define what constitutes an acceptable level of VMT effect and what could be considered a significant level of VMT effect requiring mitigation.

- **Analysis Methodology:** These are the potential procedures and tools for producing VMT forecasts to use in the VMT impact assessment.
- **Mitigation:** Projects that are found to have a significant VMT impact based on the adopted significance thresholds are required to implement mitigation measures to reduce impacts to a less than significant level (or to the extent feasible).

**Screening Criteria.** Screening criteria can be used to quickly identify whether sufficient evidence exists to presume a project will have a less than significant VMT impact without conducting a detailed study. However, each project should be evaluated against the evidence supporting that screening criteria to determine if it applies. Under OPR guidance projects meeting at least one of the criteria below can be presumed to have a less than significant VMT impact, absent substantial evidence that the project will lead to a significant impact.

- **Small Projects:** Defined as a project that generates 110 or fewer average daily vehicle trips.
- **Affordable Housing:** Defined as a project consisting of deed-restricted affordable housing.
- **Local Serving Retail:** Defined as retail uses of 50,000 square feet or less can be presumed to have a less than significant impact.
- **Proximity to High Quality Transit.** The directive notes that employment and residential development located within ½ mile of a high-quality transit corridor offering 15 minute headways can be presumed to have a less than significant impact.

**Screenline Evaluation.** The extent to which the VMT impacts of the three projects can be presumed to be less than significant has been determined based on review of the OPR directive’s screening criteria and general guidance.

The OPR **Small Project** criteria is applicable to one of the three projects. The regular operation of the Tudor Road project with 19 spaces is projected to result in 22 daily automobile trips. As the 110 ADT threshold for automobiles is not exceeded, that project’s VMT impacts can be presumed to be less than significant.

The Garden Highway at Peck Lane project with 104 spaces is projected to generate 120 daily automobile trips, while the Garden Highway at Ashcroft Lane project is projected to generate 231 daily automobile trips. Neither project can be classified as a “small project”.

The project cannot be addressed by other screen line criteria identified by OPR. The project is not an **Affordable Housing** development or **Locally Serving Retail** use.

**Projects in Low VMT-Generating Area.** Under OPR Guidelines a residential or office project that is in a VMT efficient area based on an available VMT Estimation Tool. The project must be consistent in size and land use type (i.e., density, mix of uses, transit accessibility, etc.) as the surrounding built environment.

The Sacramento Area Council of Governments (SACOG) has identified **Low VMT generating locations** within this region, including the unincorporated Sutter County area. The two Garden Highway truck parking project’s location within SACOG region was determined, and the per employee VMT characteristics of the businesses in this area of Sutter County was identified. There

is no SACOG report for the immediate area of the projects. However, the commercial areas in the general vicinity all exhibit high “per job” VMT that exceed both the SACOG regional average and the average for unincorporated Sutter County. As a result, these project’s regional VMT impact cannot be presumed to be less than significant simply based on location, and additional assessment is required.

**Additional VMT Assessment.** Because the project’s impact cannot be screened out, additional assessment was performed. The project’s VMT impacts have been assessed with regards to the actual characteristics of the activities that generate automobile VMT. As noted earlier, automobile trips would be generated as truck drivers move to and from the site and their homes, either using their personal vehicle or being dropped off. Because the project’s spaces would be rented to individual truckers who would be inclined to park near their residence, it is possible to estimate project VMT based on the forecasted daily trip generation and the average distance to area residences based on the trip distribution assumptions made earlier.

As noted in Table 5, a weighted average distance from the project area to residences in the assumed trip distribution pattern was identified for each project and applied to the daily trip generation forecasts. In turn, the VMT forecasts were divided by the number of jobs (i.e., spaces) to develop “per job” VMT. Those values were then compared to the average VMT rate that would meet a 15% VMT reduction goals for unincorporated Sutter County.

As shown, the average automobile VMT per job for the three projects ranges from 19.0 to 19.4. As a comparison the average VMT satisfying the overall Sutter County VMT reduction goal is 23.3. Because the projects’ average rates are less than the goal, their VMT impacts are not significant.

TABLE 5 VEHICLE MILES TRAVELED (VMT) ESTIMATES						
#	Location	Spaces	Daily Auto Trips	Average Distance (miles)	Vehicle Miles Traveled (VMT)	VMT per job
1	848 Tudor Road	19	22	16.39 <sup>1</sup>	360.6	19.0
2	Garden Highway @ Ashford Road	202	231	16.70 <sup>2</sup>	3,857.7	19.1
3	Garden Highway @ Peck Road	104	120	16.80 <sup>3</sup>	2,016.0	19.4
85% of average per job VMT for Unincorporated Sutter County						23.3 <sup>4</sup>
<sup>1</sup> weighted average of 55% Yuba City via SR 99 (10.9 miles), 25% Sacramento via SR 99 (32.4 miles), 10% SR 20 / George Washington Blvd (12.1 miles) and 10% Yuba City via Garden Highway (10.8 miles). <sup>2</sup> weighted average of 55% Yuba City via SR 99 (11.9 miles), 25% Sacramento via SR 99 (31.4 miles), 10% SR 20 / George Washington Blvd (13.2 miles) and 10% Yuba City via Garden Highway (10.1 miles). <sup>3</sup> weighted average of 55% Yuba City via SR 99 (12.1 miles), 25% Sacramento via SR 99 (33.2 miles), 10% SR 20 / George Washington Blvd (13.3 miles) and 10% Yuba City via Garden Highway (10.4 miles). <sup>4</sup> 85% of current average for unincorporated Sutter County (27.41VMT x .85 = 23.3 VMT per job).						

## **Impacts to Other Transportation Modes**

**Pedestrian Facilities.** There are few developed areas around the project to create pedestrian travel to and from the site. Any pedestrians would use the roadway shoulder or edge of pavement, as would be the case for any current pedestrians visiting any existing business the area. As the number of additional vehicle trips caused by the project is low and few if any pedestrians are likely, the project's impact to pedestrian facilities is not significant, and mitigation is not required.

**Bicycle Facilities.** The same issues affecting pedestrian travel also affect bicycles. The project's distance to potential employee residences is too far to make bicycling a feasible option, the project's limited trip generation would not result in any new vehicle / bicycle conflicts or exacerbate current deficiencies, and the project's impact to bicycle facilities and travel is not significant, and mitigation is not required.

**Transit.** Some employees could elect to use transit service if it was convenient to the site. The closest regular Yuba-Sutter Transit stop at the SR 99 / Bogue Road intersection is about 7-8 miles away. This distance is generally beyond normal expectations for regular transit use. Because few truckers riding transit are anticipated, the project's impact on transit use based on ridership is not significant, and mitigation is not required.

## **Safety Impacts to Caltrans Facilities**

**Considerations.** While Level of Service analysis is no longer a consideration, a project's impacts to safety on Caltrans facilities remains a significance criterion under CEQA. Under current practice, safety impacts on state facilities are typically considered within the context of queuing on off-ramps and in turn lanes at intersections, truck turning requirements and the need for alternative traffic control devices. Queuing that spills over from a turn lane or extends down an off-ramp to the mainline freeway could represent significant safety issues. Intersections where truck paths leave the pavement or encroach into opposing lanes are a safety issue. Operation of an intersection with inappropriate traffic control devices would also represent a potential safety issue.

**Evaluation.** The project could add a small amount of automobile and truck traffic through the SR 99 / SR 113 – Tudor Road interchange. However, because current traffic volumes are low that small increase would not result in any appreciable increase in queuing that might cause a safety issue as it relates to mainline SR 99. While the ramp terminal intersections are currently stop controlled, the addition of project traffic would not result in the need for signalization at these low volume levels.

The project would add truck traffic turning at the intersections at the SR 99 / SR 113 / Tudor Road interchange. However, the interchange is already handling heavy trucks that are permitted under STAA. STAA truck are not permitted at the SR 99 / Wilson Road intersection, and the pending STAA designation being pursued by Sutter County would only link Tudor Road with the project site. Thus, the project does not result in a situation where truck turns cause a safety impact.

Overall, the project's impact to safety on state facilities is not significant, and mitigation is not required.

## TRAFFIC OPERATIONAL ANALYSIS

This report section addresses the traffic operational effects of the three projects within the context of Sutter County General Plan policies and the adequacy of site access.

### **Effects based on Daily Traffic Volumes and Level of Service.**

**Traffic Volumes.** Table 6 presents the daily traffic volume contribution (i.e., trucks and automobiles) of the three projects to study area roads, as well as the sum of project trips and current traffic volumes.

**Plus Project Levels of Service.** As shown, the addition of project trips does not change the current Level of Service on any road. All roadways operate at LOS B, which satisfies the General Plan's minimum requirement, and will continue to do so with the addition of project trips.

**TABLE 6  
PROJECT TRAFFIC EFFECTS BASED ON DAILY TRAFFIC VOLUME**

Location	LOS C Threshold	Existing		Existing Plus Project Conditions			
		Daily Volume	LOS	#	Daily Volume		LOS
					Project Only	Total	
Tudor Road from SR 99 to 848 Tudor Road	10,600	1,400	B	1	35	1,435	B
				2	319	1,719	B
				3	163	1,563	B
				All	517	1,917	B
Tudor Road from 848 Tudor Road to Garden Hwy	10,600	1,400	B	1	2	1,402	B
				2	319	1,419	B
				3	163	1,563	B
				All	484	1,884	B
Garden Hwy from O'Banion Road to Tudor Road	10,600	4,280	B	1	2	4,182	B
				2	24	4,304	B
				3	12	4,292	B
				All	38	4,318	B
Garden Hwy from Tudor Road to Ashford Ave	10,600	1,400	B	1	0	1,400	B
				2	341	1,741	B
				3	175	1,575	B
				4	516	1,916	B
Garden Hwy from Ashford Ave to Peck Ave	10,600	1,400	B	1	0	1,400	B
				2	44	1,444	B
				3	175	1,575	B
				4	219	1,619	B
Garden Hwy from Peck Ave to Wilson Ave	10,600	1,100	B	1	0	1,100	B
				2	44	1,144	B
				3	24	1,124	B
				4	68	1,168	B

**Effects Based on Intersection LOS**

**Volumes.** Figures 9 and 10 present “Existing plus all 3 Projects” traffic volumes (i.e., trucks only and all vehicles).

**Levels of Service.** Table 7 presents current and “plus project” Levels of Service at the all-way stop controlled Tudor Road / Garden Highway intersection. In each case the number of heavy trucks in each movement was used to identify the truck percentage for LOS calculation. For current traffic the peak hour of truck traffic was employed for this calculation to present a “worst case” condition.

As shown, the intersections will continue to operate with Levels of Service that satisfy the General Plan’s LOS D minimum standard for peak hour conditions with and without the proposed projects.

TABLE 7 PROJECT TRAFFIC EFFECTS BASED ON INTERSECTION LEVEL OF SERVICE					
Condition	Control	Peak Hour Level of Service			
		AM Peak Hour		PM Peak Hour	
		Average Delay (sec/veh)	LOS	Average Delay (sec/veh)	LOS
Existing	AWS	7.9	A	9.0	A
Plus 848 Tudor Road		7.9	A	9.0	A
Plus Garden Hwy at Ashcroft Ave		7.9	A	9.1	A
Plus Garden Hwy at Peck Ave		7.9	A	9.0	A
Plus All 3		8.1	A	9.1	A

**Traffic Signal Warrants**

Peak hour traffic volumes at the Tudor Road / Garden Highway intersection were reviewed to determine whether the addition of project traffic may cause volumes to reach a level that satisfied traffic signal warrants. With all three projects, anticipated volumes fall below those required that satisfied Warrant 3, Peak Hour Volume.

**Site access**

Anticipated traffic volumes and truck turning requirements were reviewed at the site access to determine whether proposed improvements are adequate or additional improvements are justified.

**Sight Distance.** The alignment of Tudor Road and Garden Highway in this area is level and straight. As a result, the view measured 15 feet from the edge of the travel way would satisfy Caltrans Minimum Sight Distance (Table 201.1 500 feet at 55 mph) Corner Sight Distance (Table 405.1a 925 feet at 55 mph) ) requirements in both directions.

**Proposed Access Evaluation.** All three plans providing access treatments.

**848 Tudor Road Truck Yard.** The driveway at 848 Tudor Road already exists. The standard 8 foot paved shoulder has been widened to 14 feet beginning about 25 feet west of the 27 foot wide driveway and continuing to the east for about 500 feet. Curb returns are also provided.

Functionally, the current layout provides the pavement width needed to allow eastbound trucks to move out of the through travel lane before they reach the driveway width. However, the path of a truck entering the site that has been shown on the project site plan does not make use of the widened shoulder area, and the turn is made from the through travel lane. That drawing suggests that entering and exiting trucks would occupy most of the driveway when accessing the site. While this layout does not provide formal acceleration and deceleration lanes, such features are not judged to be necessary because the potential for conflicts with following vehicles is very low due to the very low number of trucks at the site and the low background traffic volume on Tudor Road. In addition, no trucks are likely to leave the site by turning right.

**Garden Highway at Ashcroft Avenue.** The proposed access features large radius (65 foot) corner returns. The site plan provided by the site civil engineer illustrates that the layout would allow trucks to access the site in all directions without interfering with a vehicle headed in the other direction. The layout proposes no shoulder widening nor construction of separate acceleration or deceleration lanes as required by the zoning code. Functionally, the large radius corners will allow trucks to enter the site without slowing to a crawl or stopping to wait for a conflicting vehicle. The driveway is about 900 feet from the All-way Stop at Tudor Road. Based on typical truck acceleration and deceleration rates a truck would exit the intersection and accelerate to about 35 mph before beginning to slow to enter the site when turning right.

The project is expected to create eight inbound truck trips during the weekday p.m. peak hour, or one every 7.5 minutes. While a following motorist may occasionally be delayed by a truck slowing to turn right, because background traffic volumes on Garden Highway are low, a separate deceleration treatment does not appear justified. Because truck traffic is most likely to exit by turning left due to the absences of STAA designation to the south, an acceleration lane is not justified.

**Garden Highway at Peck Avenue.** The proposed access at Peck Avenue is similar to that provided at Ashcroft Avenue and features large radius (65 foot) corner returns. The site plan provided by the site civil engineer illustrates that the layout would allow trucks to access the site in all directions without interfering with a vehicle headed in the other direction. The layout proposes no shoulder widening nor construction of separate acceleration or deceleration lanes as required by the zoning code. Functionally, the large radius corners will allow trucks to enter the site without slowing to a crawl or stopping to wait for a conflicting vehicle. The driveway is about 1,900 feet from the All-way Stop at Tudor Road. Based on typical truck acceleration and deceleration rates a truck would exit the intersection and accelerate to 55 mph before beginning to slow to enter the site when turning right.

Measured centerline to centerline the driveway appears to be about 160 feet and across the street from Ashcroft Avenue. As a private driveway, the access is not an “intersecting street” that is to meet separation standards under Section 4.6 of the Sutter County improvement standards. Because traffic volumes on Ashcroft Avenue are slow, the distance between intersections should be acceptable.

The project is expected to create four inbound truck trips during the weekday p.m. peak hour, or one every 15 minutes. While a following motorist may occasionally be delayed by a truck slowing to turn right, because background traffic volumes on Garden Highway are low, a separate deceleration treatment does not appear justified. Because truck traffic is most likely to exit by turning left due to the absence of STAA designation to the south, an acceleration lane is not justified.

## CUMULATIVE TRAFFIC OPERATIONS

### Background

This report section considers the effects of the three projects within the context of future background traffic conditions. Two perspectives were considered:

- Year 2040 conditions based on SACOG SacSim regional travel demand forecasting model results, and
- Year 2040 traffic volume forecasts from the Sutter County General Plan EIR Transportation and Circulation section.

**SACOG SacSim traffic model forecasts.** The SacSim model forecasts reflect land use assumptions made by its member agencies for development over the six county areas to the Year 2040. These assumptions rarely result in full buildout of individual areas but represent allocations of regional expectations for population and employment growth. While not all roadway segments have forecasts, Year 2040 daily traffic volumes based on that source are presented in Table 8.

**Sutter County General Plan Projections.** The General Plan EIR addresses “Adjusted Buildout” conditions that assume a much greater level of development in the Tudor Road Industrial area. As a result, its daily traffic volumes forecasts and volume created from its growth rates are much higher than those based on the SacSim traffic model. Daily traffic volumes presented in the EIR, are shown Table 8, as well as the equivalent growth rates derived from those volumes.

TABLE 8 YEAR 2040 BACKGROUND DAILY TRAFFIC VOLUMES FORECASTS						
Road	Location	Existing	SACSIM Model		General Plan <sup>1</sup>	
		Volume	Growth Rate	Volume	Volume	Growth Rate
<i>Background Volumes based on Original Data</i>						
Garden Hwy	O'Banion Rd to Tudor Rd	4,280	1.11	4,765	14,680	3.43
SR 113	George Washington Blvd to SR 99	4,500	1.06	4,750	2,640	0.69 <sup>2</sup>
<i>Background Volumes Interpolated from Each Source</i>						
Tudor Road	SR 99 to Garden Hwy	1,400	1.11	1,550	4,800	3.43
Garden Hwy	Tudor Rd to Wilson Rd	1,400	1.11	1,550	4,800	3.43
<sup>1</sup> General Plan EIR Table 6.14-11 Roadway Segment Levels of Service –2030 Adjusted Buildout <sup>2</sup> Growth rate derived from comparison of GP EIR’s “existing” volume of 3,850 and forecast of 2,640.						

**Evaluation.** The relative cumulative traffic effects of the three projects have been assessed within the context of future traffic volumes and General plan LOS thresholds. As noted in Tables 9 and 10, all study area roadways are forecast to continue to operate within the General Plan’s LOS C limit with and without the project.

**TABLE 9  
PROJECT TRAFFIC EFFECTS BASED ON CUMULATIVE DAILY TRAFFIC VOLUMES  
DERIVED FROM SACSIM REGIONAL TRAVEL DEMAND FORECASTING MODEL**

Location	LOS C Threshold	Year 2040 Background		Year 2040 Plus Project Conditions			
		Daily Volume	LOS	#	Daily Volume		LOS
					Project Only	Total	
Tudor Road from SR 99 to 848 Tudor Road	10,600	1,550	B	1	35	1,585	B
				2	319	1,869	B
				3	163	1,713	B
				All	517	2,067	B
Tudor Road from 848 Tudor Rd to Garden Hwy	10,600	1,550	B	1	2	1,552	B
				2	319	1,869	B
				3	163	1,713	B
				All	484	1,734	B
Garden Hwy from O'Banion Rd to Tudor Road	10,600	4,765	B	1	2	4,767	B
				2	24	4,789	B
				3	12	4,777	B
				All	38	4,803	B
Garden Hwy from Tudor Road to Ashford Ave	10,600	1,550	B	1	0	1,550	B
				2	341	1,891	B
				3	175	1,725	B
				4	516	2,066	B
Garden Hwy from Ashford Ave to Peck Ave	10,600	1,550	B	1	0	1,550	B
				2	44	1,594	B
				3	175	1,725	B
				4	219	1,769	B
Garden Hwy from Peck Ave to Wilson Avenue	10,600	1,220	B	1	0	1,220	B
				2	44	1,264	B
				3	24	1,244	B
				4	68	1,288	B

**TABLE 10  
PROJECT TRAFFIC EFFECTS BASED ON CUMULATIVE DAILY TRAFFIC VOLUMES  
DERIVED FROM SUTTER COUNTY GENERAL PLAN EIR FORECASTS**

Location	LOS C Threshold	Year 2040 Background		Year 2040 Plus Project Conditions			
		Daily Volume	LOS	#	Daily Volume		LOS
					Project Only	Total	
Tudor Road from SR 99 to 848 Tudor Road	10,600	4,800	B	1	35	4,835	B
				2	319	5,119	B
				3	163	4,963	B
				All	517	5,317	B
Tudor Road from 848 Tudor Rd to Garden Hwy	10,600	4,800	B	1	2	4,802	B
				2	319	5,119	B
				3	163	4,963	B
				All	484	5,284	B
Garden Hwy from O'Banion Rd to Tudor Road	17,520 <sup>1</sup>	14,680	B	1	2	14,682	B
				2	24	14,704	B
				3	12	14,692	B
				All	38	14,718	B
Garden Hwy from Tudor Road to Ashford Ave	10,600	4,800		1	0	4,800	B
				2	341	5,141	B
				3	175	4,975	B
				4	516	5,316	B
Garden Hwy from Ashford Ave to Peck Ave	10,600	4,800	B	1	0	4,800	B
				2	44	4,844	B
				3	175	4,975	B
				4	219	5,019	B
Garden Hwy from Peck Ave to Wilson Avenue	10,600	3,800	B	1	0	3,800	B
				2	44	3,844	B
				3	24	3,824	B
				4	68	2,868	B

<sup>1</sup> Roadway improved to urban three—lane in GP EIR

**APPENDIX C**  
**ENVIRONMENTAL NOISE ANALYSIS**



## Environmental Noise Assessment

# Three Truck Parking Facilities on Tudor Road and Garden Highway

Sutter County, California

June 28, 2022

Project #220103

Prepared for:

JOVAN ORCHARDS  
1728 Regency Way  
Yuba City, CA 95993

c/o Mr. Mundeep Dhami

Prepared by:

Saxelby Acoustics LLC

A blue ink signature of Luke Saxelby.

Luke Saxelby, INCE Bd. Cert.  
Principal Consultant  
Board Certified, Institute of Noise Control Engineering (INCE)



(916) 760-8821  
www.SaxNoise.com | Luke@SaxNoise.com  
915 Highland Pointe Drive, Suite 250  
Roseville, CA 95678

## INTRODUCTION

The Garden Highway and Tudor Road Truck Parking Project is located in Sutter County, California. This analysis considers three heavy truck parking facilities. Site 1 is located along Tudor Road. Sites 2 and 3 are located along Garden Highway. This analysis will predict the noise generation associated with these uses and will seek to achieve compliance with the applicable Sutter County noise level standards.

**Figures 1a, 1b, and 1c** show the project site plans. **Figure 2** shows an aerial photo of all three project sites and noise measurement locations.

## ENVIRONMENTAL SETTING

### BACKGROUND INFORMATION ON NOISE

#### *Fundamentals of Acoustics*

Acoustics is the science of sound. Sound may be thought of as mechanical energy of a vibrating object transmitted by pressure waves through a medium to human (or animal) ears. If the pressure variations occur frequently enough (at least 20 times per second), then they can be heard and are called sound. The number of pressure variations per second is called the frequency of sound, and is expressed as cycles per second or Hertz (Hz).

Noise is a subjective reaction to different types of sounds. Noise is typically defined as (airborne) sound that is loud, unpleasant, unexpected or undesired, and may therefore be classified as a more specific group of sounds. Perceptions of sound and noise are highly subjective from person to person.

Measuring sound directly in terms of pressure would require a very large and awkward range of numbers. To avoid this, the decibel scale was devised. The decibel scale uses the hearing threshold (20 micropascals), as a point of reference, defined as 0 dB. Other sound pressures are then compared to this reference pressure, and the logarithm is taken to keep the numbers in a practical range. The decibel scale allows a million-fold increase in pressure to be expressed as 120 dB, and changes in levels (dB) correspond closely to human perception of relative loudness.

The perceived loudness of sounds is dependent upon many factors, including sound pressure level and frequency content. However, within the usual range of environmental noise levels, perception of loudness is relatively predictable, and can be approximated by A-weighted sound levels. There is a strong correlation between A-weighted sound levels (expressed as dBA) and the way the human ear perceives sound. For this reason, the A-weighted sound level has become the standard tool of environmental noise assessment. All noise levels reported in this section are in terms of A-weighted levels, but are expressed as dB, unless otherwise noted.

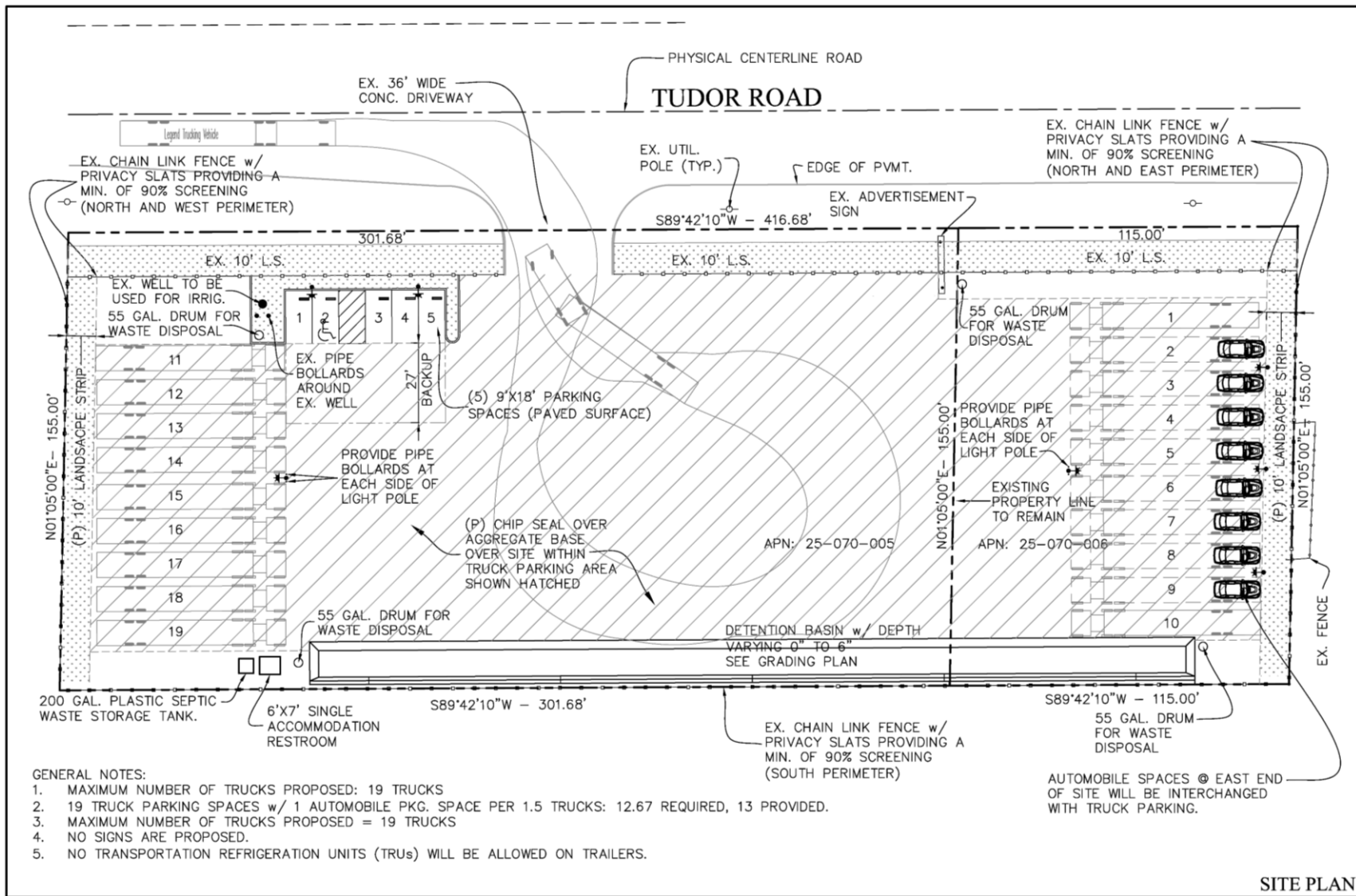

**Garden Highway & Tudor Road Truck Parking Project**  
Sutter County, California

Figure 1a  
Project Site Plan – Site 1



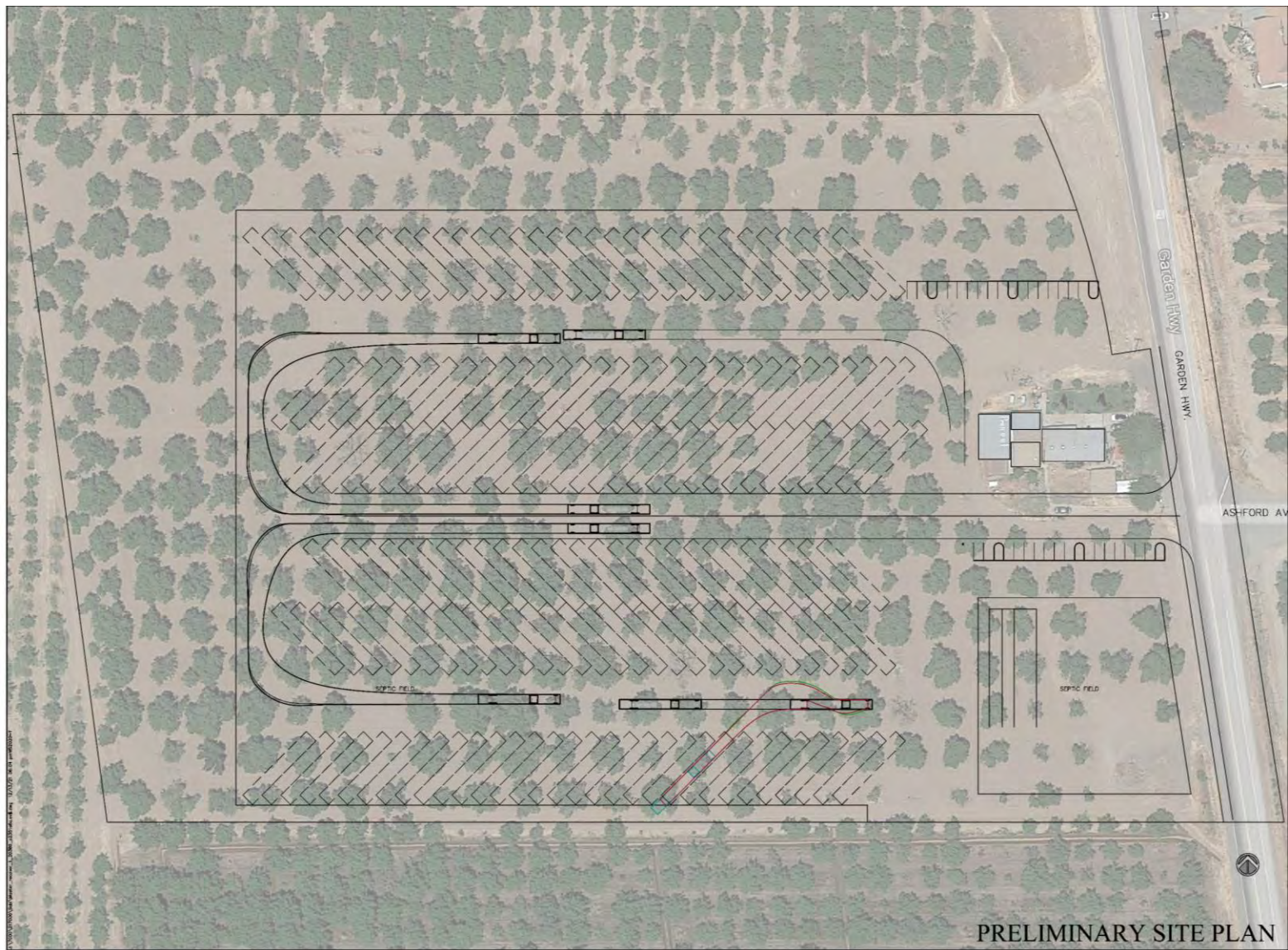

**Garden Highway & Tudor Road Truck Parking Project**  
 Sutter County, California

Figure 1b  
 Project Site Plan – Site 2



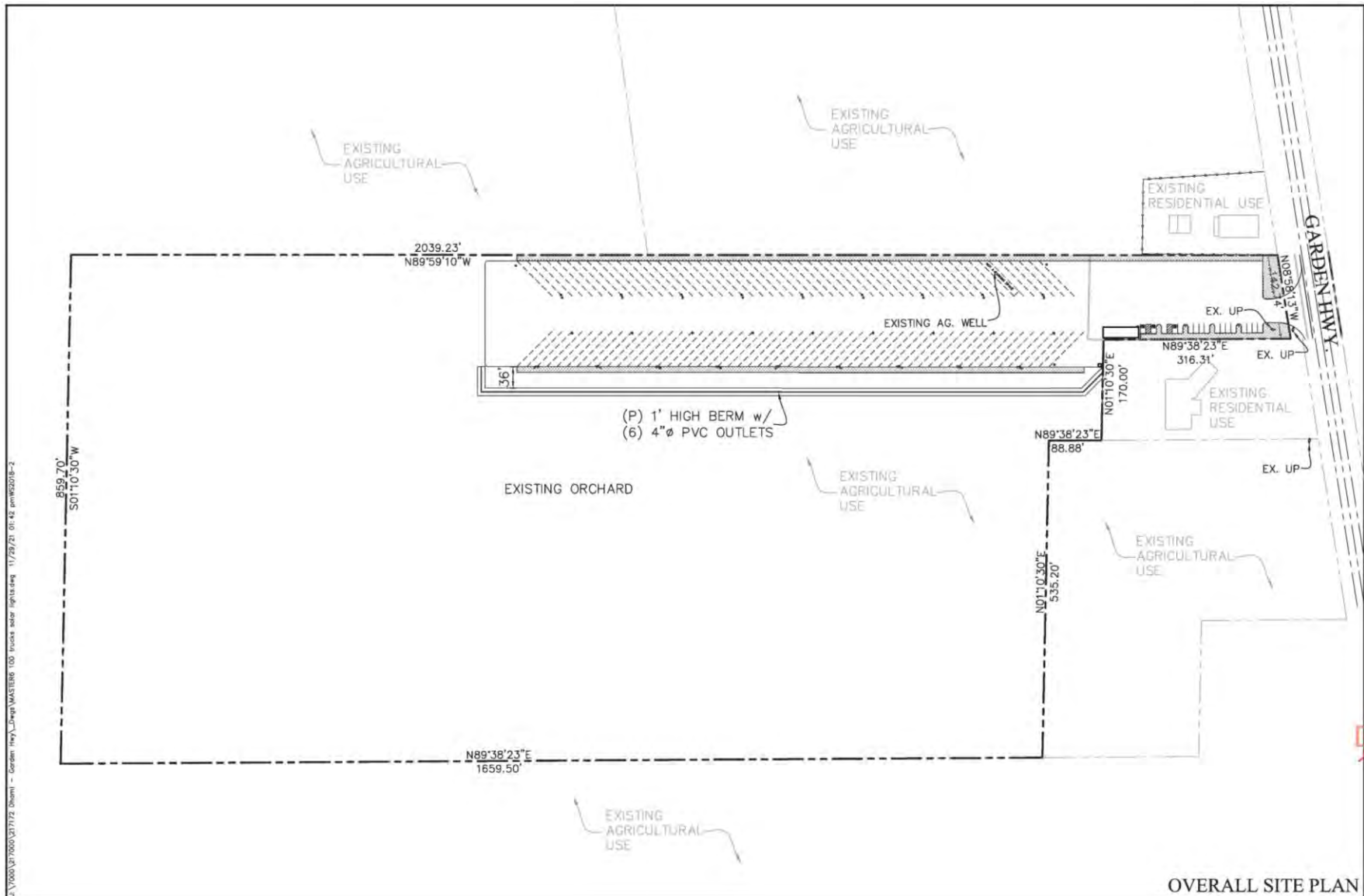

OVERALL SITE PLAN

**Garden Highway & Tudor Road Truck Parking Project**  
 Sutter County, California

Figure 1c  
 Project Site Plan – Site 3



# Garden Hwy & Tudor Rd Truck Parking Project

Sutter County, California

Figure 2

Noise Measurement Sites



## Legend

- Project Site
- ▲ Noise Measurement Site - Long Term

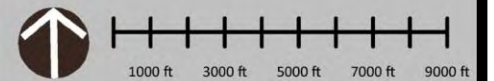

Projection: UTM Zone 10 / WGS84 / meters  
Rev. Date: 02/09/2022



The decibel scale is logarithmic, not linear. In other words, two sound levels 10-dB apart differ in acoustic energy by a factor of 10. When the standard logarithmic decibel is A-weighted, an increase of 10-dBA is generally perceived as a doubling in loudness. For example, a 70-dBA sound is half as loud as an 80-dBA sound, and twice as loud as a 60 dBA sound.

Community noise is commonly described in terms of the ambient noise level, which is defined as the all-encompassing noise level associated with a given environment. A common statistical tool is the average, or equivalent, sound level ( $L_{eq}$ ), which corresponds to a steady-state A weighted sound level containing the same total energy as a time varying signal over a given time period (usually one hour). The  $L_{eq}$  is the foundation of the composite noise descriptor,  $L_{dn}$ , and shows very good correlation with community response to noise.

The day/night average level ( $L_{dn}$ ) is based upon the average noise level over a 24-hour day, with a +10-decibel weighing applied to noise occurring during nighttime (10:00 p.m. to 7:00 a.m.) hours. The nighttime penalty is based upon the assumption that people react to nighttime noise exposures as though they were twice as loud as daytime exposures. Because  $L_{dn}$  represents a 24-hour average, it tends to disguise short-term variations in the noise environment.

**Table 1** lists several examples of the noise levels associated with common situations. **Appendix A** provides a summary of acoustical terms used in this report.

**TABLE 1: TYPICAL NOISE LEVELS**

Common Outdoor Activities	Noise Level (dBA)	Common Indoor Activities
	--110--	Rock Band
Jet Fly-over at 300 m (1,000 ft.)	--100--	
Gas Lawn Mower at 1 m (3 ft.)	--90--	
Diesel Truck at 15 m (50 ft.), at 80 km/hr. (50 mph)	--80--	Food Blender at 1 m (3 ft.) Garbage Disposal at 1 m (3 ft.)
Noisy Urban Area, Daytime Gas Lawn Mower, 30 m (100 ft.)	--70--	Vacuum Cleaner at 3 m (10 ft.)
Commercial Area Heavy Traffic at 90 m (300 ft.)	--60--	Normal Speech at 1 m (3 ft.)
Quiet Urban Daytime	--50--	Large Business Office Dishwasher in Next Room
Quiet Urban Nighttime	--40--	Theater, Large Conference Room (Background)
Quiet Suburban Nighttime	--30--	Library
Quiet Rural Nighttime	--20--	Bedroom at Night, Concert Hall (Background)
	--10--	Broadcast/Recording Studio
Lowest Threshold of Human Hearing	--0--	Lowest Threshold of Human Hearing

Source: Caltrans, Technical Noise Supplement, Traffic Noise Analysis Protocol. September, 2013.

### ***Effects of Noise on People***

The effects of noise on people can be placed in three categories:

- Subjective effects of annoyance, nuisance, and dissatisfaction
- Interference with activities such as speech, sleep, and learning
- Physiological effects such as hearing loss or sudden startling

Environmental noise typically produces effects in the first two categories. Workers in industrial plants can experience noise in the last category. There is no completely satisfactory way to measure the subjective effects of noise or the corresponding reactions of annoyance and dissatisfaction. A wide variation in individual thresholds of annoyance exists and different tolerances to noise tend to develop based on an individual's past experiences with noise.

Thus, an important way of predicting a human reaction to a new noise environment is the way it compares to the existing environment to which one has adapted: the so-called ambient noise level. In general, the more a new noise exceeds the previously existing ambient noise level, the less acceptable the new noise will be judged by those hearing it.

With regard to increases in A-weighted noise level, the following relationships occur:

- Except in carefully controlled laboratory experiments, a change of 1-dBA cannot be perceived;
- Outside of the laboratory, a 3-dBA change is considered a just-perceivable difference;
- A change in level of at least 5-dBA is required before any noticeable change in human response would be expected; and
- A 10-dBA change is subjectively heard as approximately a doubling in loudness, and can cause an adverse response.

Stationary point sources of noise – including stationary mobile sources such as idling vehicles – attenuate (lessen) at a rate of approximately 6-dB per doubling of distance from the source, depending on environmental conditions (i.e. atmospheric conditions and either vegetative or manufactured noise barriers, etc.). Widely distributed noises, such as a large industrial facility spread over many acres, or a street with moving vehicles, would typically attenuate at a lower rate.

## EXISTING AMBIENT NOISE LEVELS

The existing ambient noise environment in the project vicinity is primarily defined by traffic on the local roadways adjacent to the project sites, including Tudor Road and Garden Highway.

To quantify the existing ambient noise environment in the project vicinity, Saxelby Acoustics conducted a continuous (24-hr.) noise level measurement at three locations. Noise measurement locations are shown on **Figure 2**. A summary of the noise level measurement survey results is provided in **Table 2. Appendix B** contains the complete results of the noise monitoring.

The sound level meters were programmed to record the maximum, median, and average noise levels at each site during the survey. The maximum value, denoted  $L_{max}$ , represents the highest noise level measured. The average value, denoted  $L_{eq}$ , represents the energy average of all of the noise received by the sound level meter microphone during the monitoring period. The median value, denoted  $L_{50}$ , represents the sound level exceeded 50 percent of the time during the monitoring period.

Larson Davis Laboratories (LDL) model 820 precision integrating sound level meters were used for the ambient noise level measurement survey. The meters were calibrated before and after use with a LDL CAL200 acoustical calibrator to ensure the accuracy of the measurements. The equipment used meets all pertinent specifications of the American National Standards Institute for Type 1 sound level meters (ANSI S1.4).

**Table 2: Summary of Existing Background Noise Measurement Data**

Site	Date	$L_{dn}$	Daytime	Daytime	Daytime	Nighttime	Nighttime	Nighttime
			$L_{eq}$	$L_{50}$	$L_{max}$	$L_{eq}$	$L_{50}$	$L_{max}$
LT-1	1/20/22	60	58	51	79	53	47	68
LT-2	1/20/22	58	53	46	69	52	43	68
LT-3	1/20/22	56	51	46	67	49	40	65

Notes:

- All values shown in dBA
- Daytime hours: 7:00 a.m. to 10:00 p.m.
- Nighttime Hours: 10:00 p.m. to 7:00 a.m.
- Source: Saxelby Acoustics 2022

## REGULATORY CONTEXT

### FEDERAL

There are no federal regulations related to noise that apply to the Proposed Project.

### STATE

There are no state regulations related to noise that apply to the Proposed Project.

### LOCAL

#### ***Sutter County General Plan***

The Sutter County General Plan Noise Element establishes acceptable noise levels for residential uses affected by transportation and stationary noise sources. The relevant criteria are reproduced below:

**TABLE 3: NOISE LEVEL STANDARDS FROM STATIONARY SOURCES**

Noise Level Descriptor	Daytime (7:00 a.m. to 10:00 p.m.)	Nighttime (10:00 p.m. to 7:00 a.m.)
Hourly $L_{eq}$ , dB	55	45
Maximum Level, dB	70	65

Source: Sutter County General Plan Table 11-3

#### ***Sutter County Municipal Code***

##### 1500-21.5-050 Exterior Noise Standards

The noise standards shown in Table 1500-21.5-1 (**Table 4** below), unless otherwise specified in this Article, shall apply to all noise sensitive exterior areas within Sutter County.

**TABLE 4: EXTERIOR NOISE STANDARDS**

Noise Level Descriptor	Daytime (7:00 a.m. to 10:00 p.m.)	Nighttime (10:00 p.m. to 7:00 a.m.)
Hourly $L_{eq}$ , dBA	55	45
Maximum Level, dBA	70	65

Source: Table 1500-21.5-1 of Sutter County Municipal Code

- A. *Exterior Noise Violation.* It is unlawful for any person at any location within the County to create any noise which causes the noise levels on a noise sensitive receiving property, when measured in the designated exterior noise measurement location, to exceed the noise standards specified in Table 1500-21.5-1.
- B. *Impulsive, Simple and Pure Tone Noise.* Each of the noise limits specified in Table 1500-21.5-1 shall be reduced by 5 dBA for recurring impulsive noise, simple or pure tone noise, or for noises consisting of speech or music.

- C. *Ambient Noise Level.* Noise level standards, which are up to five 5 dBA less than those specified in Table 1500-21.5-1 may be imposed, based upon determination of existing low ambient noise levels in the vicinity of the receiving property.
- D. *Application.* The exterior noise level standard shall be applied to the property line of the receiving property (as measured no more than one foot or as close as practicable inside the property line).

(Ord. No. 1661, § 17, 6-11-2019)

#### 1500-21.5-070 Exceptions to Noise Standards

The following activities shall be exempted from the provisions of this Article:

- B. *Construction.* Noise sources associated with construction, repair, remodeling, demolition, paving or grading of any real property or public works project located within 1,000 feet of noise-sensitive uses (i.e., residential uses, daycares, schools, convalescent homes, and medical care facilities), provided such activities take place between:
  - 1. 7:00 a.m. to 6:00 p.m. on weekdays
  - 2. 8:00 a.m. to 5:00 p.m. on Saturdays

Construction is prohibited on Sundays and legal holidays unless permission has been applied for and granted by the County.

#### ***Summary of Sutter County Regulatory Context***

**Table 3** shows the acceptable noise levels that may be generated by stationary noise sources as established in the General Plan. **Table 6** shows the Municipal Code standards for Sutter County. For this analysis, the more restrictive **Table 3** General Plan standards will be applied to the project.

## EVALUATION OF PROJECT OPERATIONAL NOISE AT RESIDENTIAL RECEPTORS

The primary noise source on the proposed project sites would be parking lot circulation of heavy trucks and automobiles. It is expected that the proposed projects sites would be used for either “Long Haul” or “Local Distribution or Agricultural Harvesting / Processing support.” Trip generations for Site 1 to Site 3 were provided by the traffic engineer (KD Anderson & Associates, 2022). The assumptions for trip generations at each site are summarized below.

Site 1: 1 Heavy truck, 2 automobiles in peak hour. KD Anderson & Associates data.

Site 2: 11 Heavy trucks, 17 automobiles in peak hour. KD Anderson & Associates data.

Site 3: 6 Heavy trucks, 9 automobiles in peak hour. KD Anderson & Associates data.

It should be noted that all three project sites are predicted to operate at the same capacity during both daytime (7:00 a.m. to 10:00 p.m.) and nighttime (10:00 p.m. to 7:00 a.m.) hours. Therefore, the project must comply with the more restrictive nighttime noise level standard of 45 dBA  $L_{eq}$ . Additionally, parking lot noise generation caused by heavy trucks and automobiles is expected to produce noise levels no more than 20 dBA higher than the average ( $L_{eq}$ ) noise levels. The nighttime maximum noise level standard of 65 dBA  $L_{max}$  is 20 dBA higher than the nighttime average ( $L_{eq}$ ) noise level standard. Therefore, where the project complies with the nighttime  $L_{eq}$  standard, the project will also comply with the nighttime  $L_{max}$  standard.

Based upon noise measurements conducted of vehicle movements in parking lots and truck parking facilities, the sound exposure level (SEL) for a single passenger vehicle is 71 dBA at a distance of 50 feet while the SEL of a tractor-trailer is 85 dBA at the same distance.

Saxelby Acoustics used the SoundPLAN noise prediction model. Inputs to the model included sound power levels for the proposed parking lots, existing and proposed buildings, terrain type, and locations of sensitive receptors. These predictions are made in accordance with International Organization for Standardization (ISO) standard 9613-2:1996 (Acoustics – Attenuation of sound during propagation outdoors). ISO 9613 is the most commonly used method for calculating exterior noise propagation. The results of this analysis are shown graphically on **Figures 3-5** for Site 1, Site 2, and Site 3 respectively.

As shown on **Figures 3 and 4**, Site 1 and Site 2 will produce noise levels of 45 dBA  $L_{eq}$  or less at the adjacent residential uses. However, as shown on **Figure 5**, the Site 3 project will produce noise levels of 46 dBA at the nearest residential property. Therefore, noise control measures will be required for this project site.

# Garden Hwy & Tudor Rd Truck Parking Project

Sutter County, California

Figure 3

Site 1 Project Noise Contours (dBA  $L_{eq}$ )



## Signs and symbols

— Project Boundary

## Levels in dB(A)

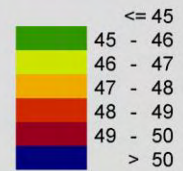

1 : 1300

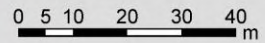

# Garden Hwy & Tudor Rd Truck Parking Project

Sutter County, California

Figure 4

Site 2 Project Noise Contours (dBA  $L_{eq}$ )

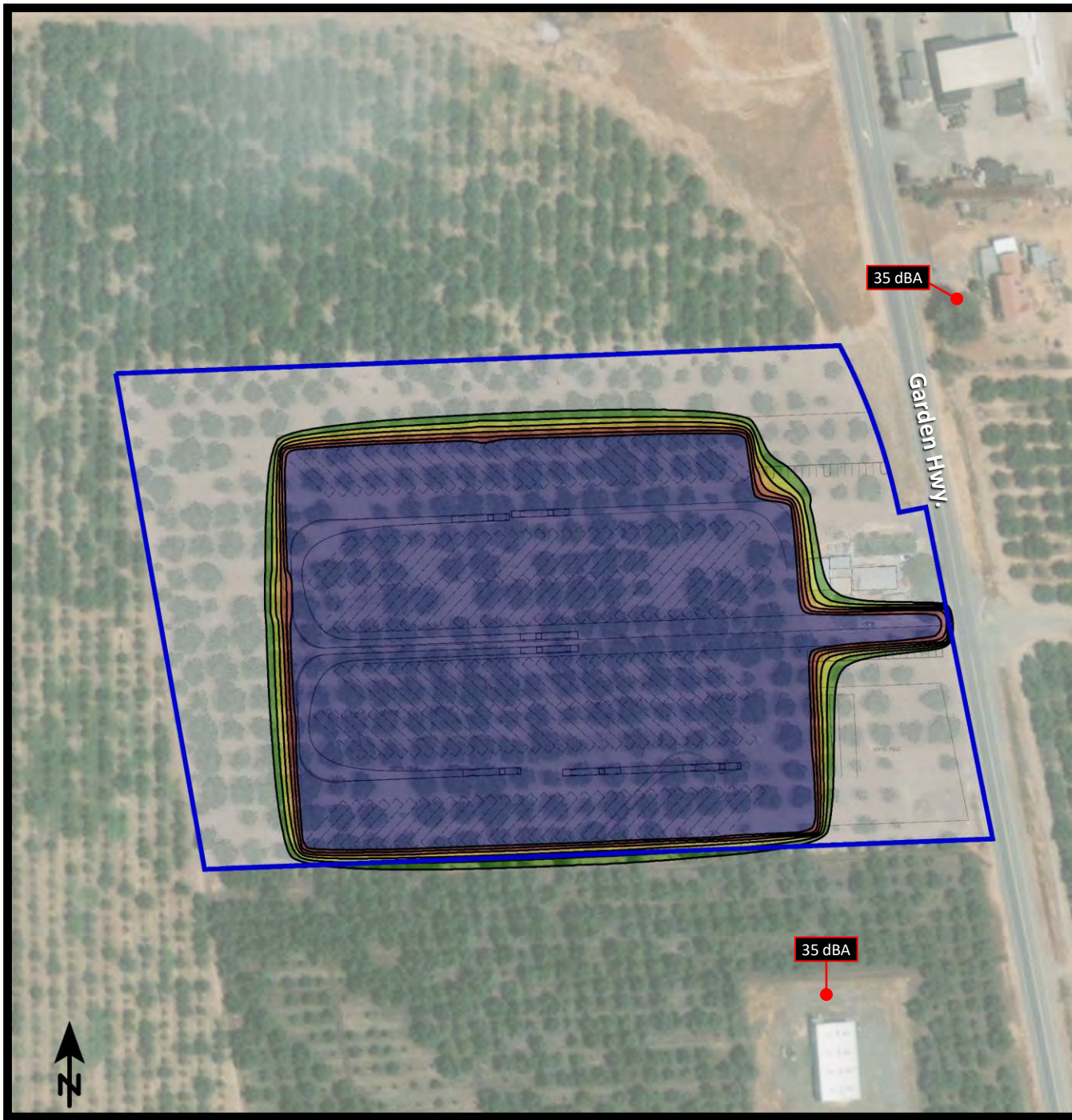

### Signs and symbols

— Project Boundary

### Levels in dB(A)

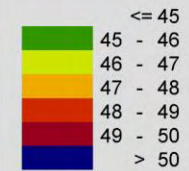

1 : 2250

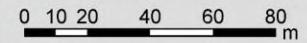

# Garden Hwy & Tudor Rd Truck Parking Project

Sutter County, California

Figure 5

Site 3 Project Noise Contours (dBA  $L_{eq}$ )

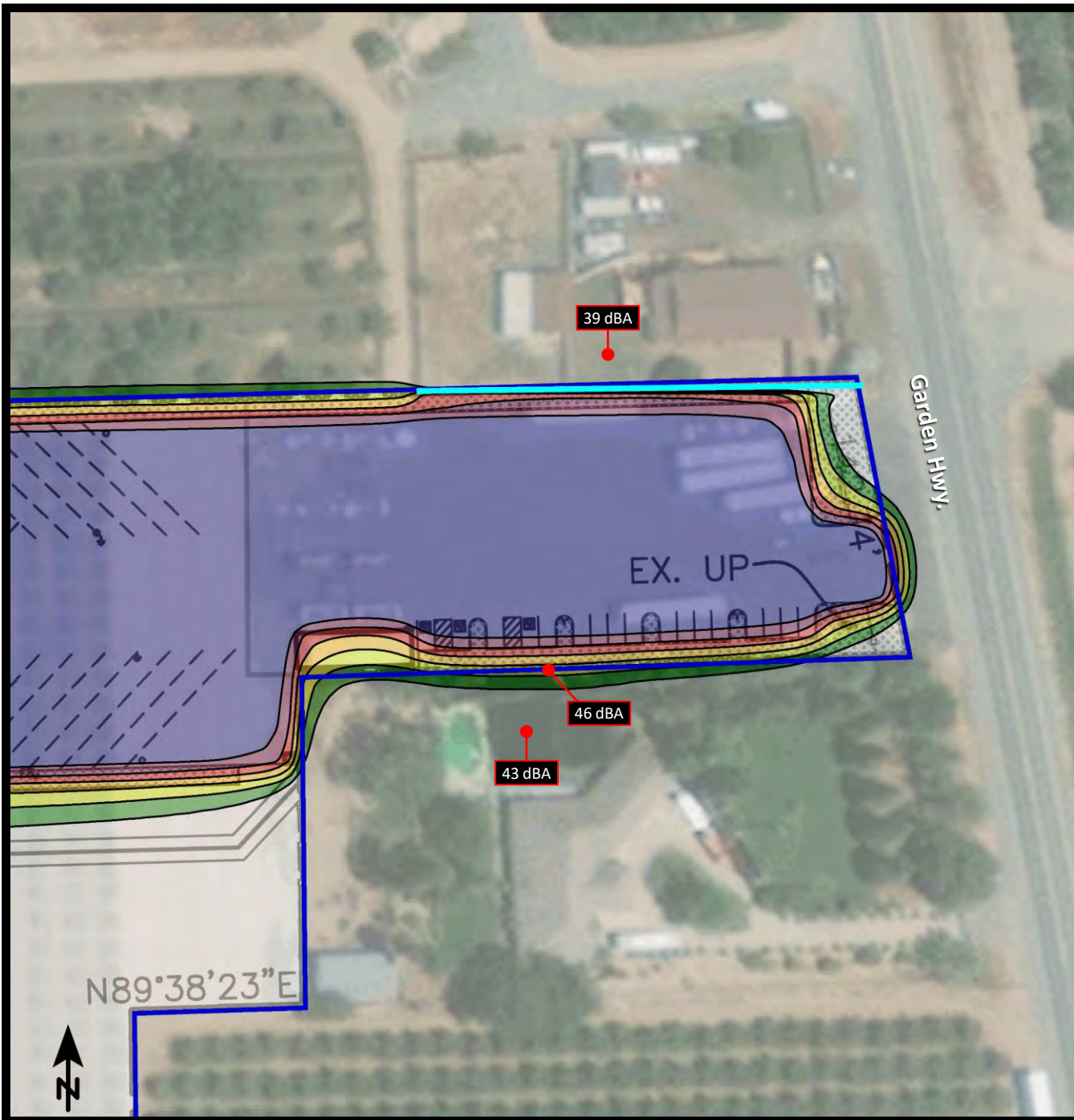

## Signs and symbols

- Project Boundary
- Existing Sound Wall

## Levels in dB(A)

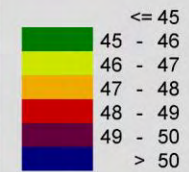

1 : 900

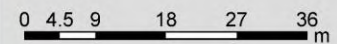

## NOISE CONTROL MEASURES

As shown on **Figure 5**, the proposed Site 3 project is predicted to generate noise levels of approximately 46 dBA at the property line of the residential use to the south. This exceeds the Sutter County nighttime (10:00 p.m. to 7:00 a.m.) noise level standard of 45 dBA  $L_{eq}$ . Therefore, noise control measures are required.

To comply with the Sutter County noise level standards, the project (Site 3) must include the construction of a 6-foot-tall sound wall along the project boundary. The wall location and resulting noise level contours are shown graphically on **Figure 6**. Implementation of this noise control measure will allow the project to meet all Sutter County noise level standards.



# Garden Hwy & Tudor Rd Truck Parking Project

Sutter County, California

Figure 6

Site 3 Project Noise Contours (dBA  $L_{eq}$ )

Noise Control Measures

### Signs and symbols

- Project Boundary
- Existing Sound Wall
- Recommended 6-Foot Sound Wall

### Levels in dB(A)

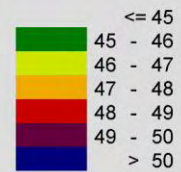

1 : 900

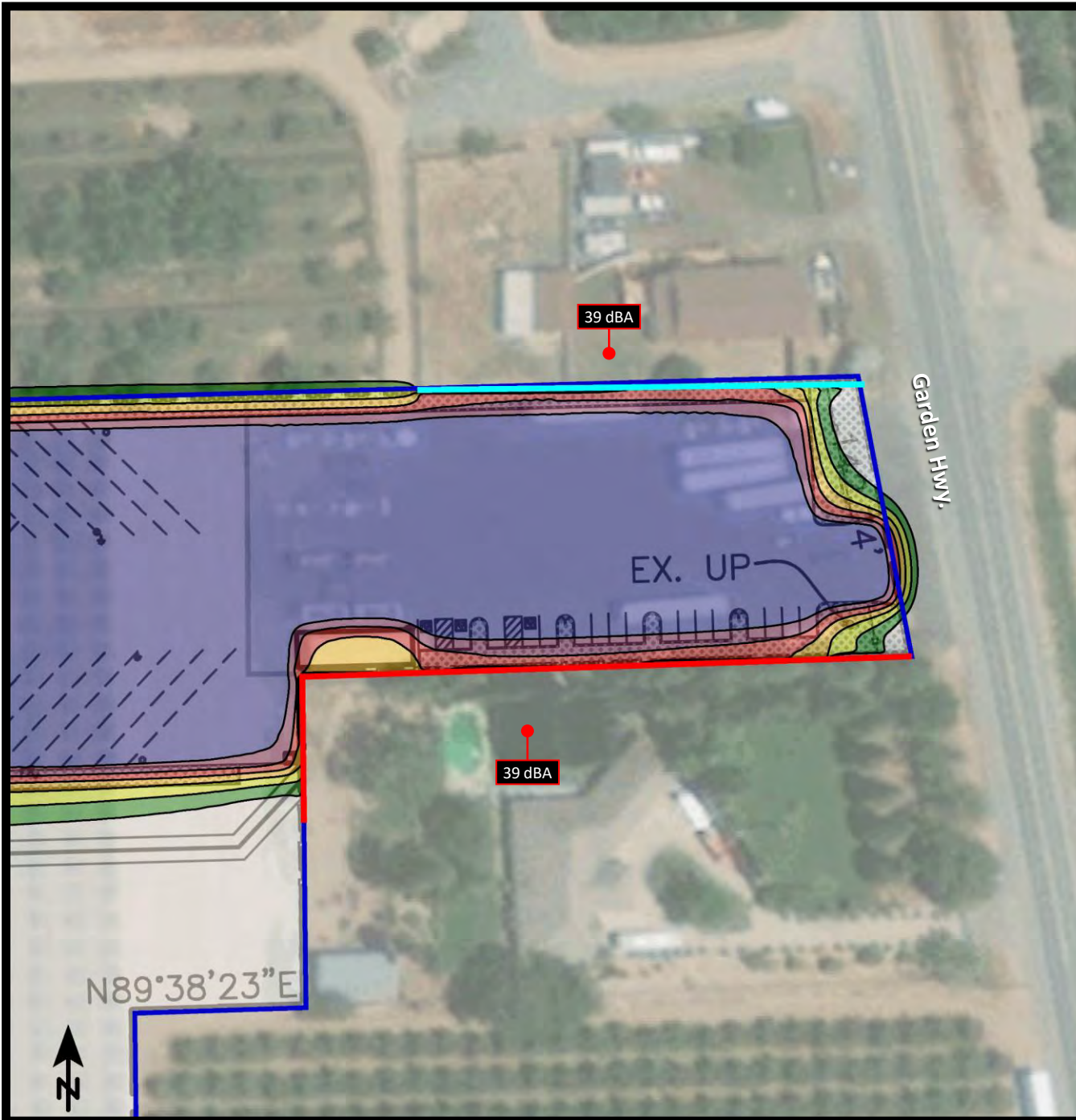

## CONCLUSIONS

The proposed Site 1 and Site 2 project sites are predicted to comply with the Sutter County noise level standards with no additional noise control measures. The Site 3 project is predicted to exceed the Sutter County nighttime (10:00 p.m. to 7:00 a.m.) noise level standard of 45 dBA  $L_{eq}$  by approximately 1 dB. To achieve compliance with the Sutter County standards, the following noise control measure must be implemented:

- A 6-foot-tall sound wall must be constructed along the southern project boundary (Site 3) as illustrated on **Figure 6**.

Implementation of this noise control measure will allow project Site 1, Site 2, and Site 3 to meet all Sutter County noise level standards.

## Appendix A: Acoustical Terminology

<b>Acoustics</b>	The science of sound.
<b>Ambient Noise</b>	The distinctive acoustical characteristics of a given space consisting of all noise sources audible at that location. In many cases, the term ambient is used to describe an existing or pre-project condition such as the setting in an environmental noise study.
<b>ASTC</b>	Apparent Sound Transmission Class. Similar to STC but includes sound from flanking paths and correct for room reverberation. A larger number means more attenuation. The scale, like the decibel scale for sound, is logarithmic.
<b>Attenuation</b>	The reduction of an acoustic signal.
<b>A-Weighting</b>	A frequency-response adjustment of a sound level meter that conditions the output signal to approximate human response.
<b>Decibel or dB</b>	Fundamental unit of sound, A Bell is defined as the logarithm of the ratio of the sound pressure squared over the reference pressure squared. A Decibel is one-tenth of a Bell.
<b>CNEL</b>	Community Noise Equivalent Level. Defined as the 24-hour average noise level with noise occurring during evening hours (7 - 10 p.m.) weighted by +5 dBA and nighttime hours weighted by +10 dBA.
<b>DNL</b>	See definition of Ldn.
<b>IIC</b>	Impact Insulation Class. An integer-number rating of how well a building floor attenuates impact sounds, such as footsteps. A larger number means more attenuation. The scale, like the decibel scale for sound, is logarithmic.
<b>Frequency</b>	The measure of the rapidity of alterations of a periodic signal, expressed in cycles per second or hertz (Hz).
<b>Ldn</b>	Day/Night Average Sound Level. Similar to CNEL but with no evening weighting.
<b>Leq</b>	Equivalent or energy-averaged sound level.
<b>Lmax</b>	The highest root-mean-square (RMS) sound level measured over a given period of time.
<b>L(n)</b>	The sound level exceeded a described percentile over a measurement period. For instance, an hourly L50 is the sound level exceeded 50% of the time during the one-hour period.
<b>Loudness</b>	A subjective term for the sensation of the magnitude of sound.
<b>NIC</b>	Noise Isolation Class. A rating of the noise reduction between two spaces. Similar to STC but includes sound from flanking paths and no correction for room reverberation.
<b>NNIC</b>	Normalized Noise Isolation Class. Similar to NIC but includes a correction for room reverberation.
<b>Noise</b>	Unwanted sound.
<b>NRC</b>	Noise Reduction Coefficient. NRC is a single-number rating of the sound-absorption of a material equal to the arithmetic mean of the sound-absorption coefficients in the 250, 500, 1000, and 2,000 Hz octave frequency bands rounded to the nearest multiple of 0.05. It is a representation of the amount of sound energy absorbed upon striking a particular surface. An NRC of 0 indicates perfect reflection; an NRC of 1 indicates perfect absorption.
<b>RT60</b>	The time it takes reverberant sound to decay by 60 dB once the source has been removed.
<b>Sabin</b>	The unit of sound absorption. One square foot of material absorbing 100% of incident sound has an absorption of 1 Sabin.
<b>SEL</b>	Sound Exposure Level. SEL is a rating, in decibels, of a discrete event, such as an aircraft flyover or train pass by, that compresses the total sound energy into a one-second event.
<b>SPC</b>	Speech Privacy Class. SPC is a method of rating speech privacy in buildings. It is designed to measure the degree of speech privacy provided by a closed room, indicating the degree to which conversations occurring within are kept private from listeners outside the room.
<b>STC</b>	Sound Transmission Class. STC is an integer rating of how well a building partition attenuates airborne sound. It is widely used to rate interior partitions, ceilings/floors, doors, windows and exterior wall configurations. The STC rating is typically used to rate the sound transmission of a specific building element when tested in laboratory conditions where flanking paths around the assembly don't exist. A larger number means more attenuation. The scale, like the decibel scale for sound, is logarithmic.
<b>Threshold of Hearing</b>	The lowest sound that can be perceived by the human auditory system, generally considered to be 0 dB for persons with perfect hearing.
<b>Threshold of Pain</b>	Approximately 120 dB above the threshold of hearing.
<b>Impulsive</b>	Sound of short duration, usually less than one second, with an abrupt onset and rapid decay.
<b>Simple Tone</b>	Any sound which can be judged as audible as a single pitch or set of single pitches.

## Appendix B: Continuous Ambient Noise Measurement Results



**Appendix B1: Continuous Noise Monitoring Results**

Site: LT-1

Project: Garden Hwy & Tudor Rd Parking

Meter: LDL 820-2

Location: Southern Project Boundary - Site 1

Calibrator: CAL200

Coordinates: 39.0029688°, -121.6247701°

Date	Time	Measured Level, dBA			
		L <sub>eq</sub>	L <sub>max</sub>	L <sub>50</sub>	L <sub>90</sub>
Thursday, January 20, 2022	0:00	46	60	42	35
Thursday, January 20, 2022	1:00	47	62	43	35
Thursday, January 20, 2022	2:00	46	64	42	35
Thursday, January 20, 2022	3:00	49	67	46	40
Thursday, January 20, 2022	4:00	53	75	49	44
Thursday, January 20, 2022	5:00	56	71	52	49
Thursday, January 20, 2022	6:00	59	72	56	52
Thursday, January 20, 2022	7:00	57	72	55	52
Thursday, January 20, 2022	8:00	58	84	54	50
Thursday, January 20, 2022	9:00	56	85	51	46
Thursday, January 20, 2022	10:00	52	85	46	41
Thursday, January 20, 2022	11:00	56	88	46	42
Thursday, January 20, 2022	12:00	63	87	58	50
Thursday, January 20, 2022	13:00	57	71	56	53
Thursday, January 20, 2022	14:00	62	93	56	53
Thursday, January 20, 2022	15:00	54	68	52	49
Thursday, January 20, 2022	16:00	56	85	51	48
Thursday, January 20, 2022	17:00	60	84	49	44
Thursday, January 20, 2022	18:00	54	72	49	45
Thursday, January 20, 2022	19:00	53	71	48	44
Thursday, January 20, 2022	20:00	54	71	49	45
Thursday, January 20, 2022	21:00	51	72	47	43
Thursday, January 20, 2022	22:00	51	72	46	42
Thursday, January 20, 2022	23:00	48	69	44	40

Statistics	Leq	Lmax	L50	L90
Day Average	58	79	51	47
Night Average	53	68	47	41
Day Low	51	68	46	41
Day High	63	93	58	53
Night Low	46	60	42	35
Night High	59	75	56	52
Ldn	60	Day %		84
CNEL	61	Night %		16

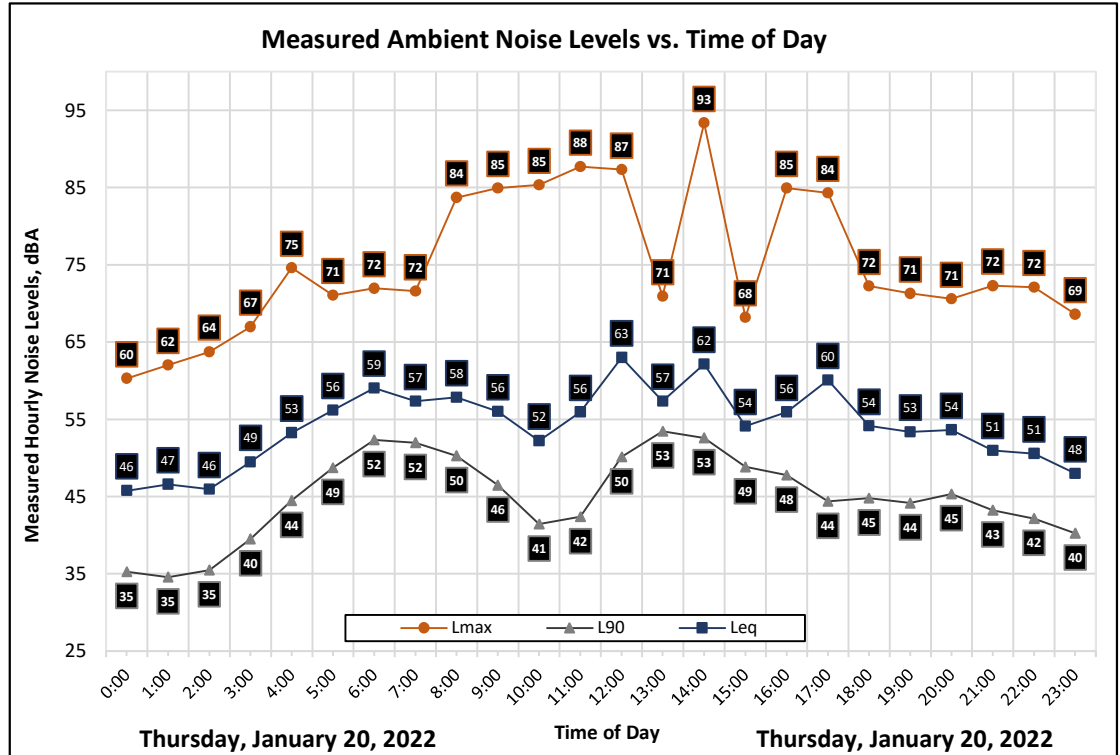

**Appendix B2: Continuous Noise Monitoring Results**

Site: LT-2

Project: Garden Hwy & Tudor Rd Parking

Meter: LDL 820-6

Location: Northeastern Project Boundary - Site 2

Calibrator: CAL200

Coordinates: 39.0022883°, -121.6103026°

Date	Time	Measured Level, dBA			
		L <sub>eq</sub>	L <sub>max</sub>	L <sub>50</sub>	L <sub>90</sub>
Thursday, January 20, 2022	0:00	46	65	39	34
Thursday, January 20, 2022	1:00	42	59	39	32
Thursday, January 20, 2022	2:00	42	61	37	33
Thursday, January 20, 2022	3:00	48	70	40	35
Thursday, January 20, 2022	4:00	50	68	44	38
Thursday, January 20, 2022	5:00	55	72	51	44
Thursday, January 20, 2022	6:00	58	79	55	50
Thursday, January 20, 2022	7:00	57	70	54	49
Thursday, January 20, 2022	8:00	54	69	51	48
Thursday, January 20, 2022	9:00	53	70	50	46
Thursday, January 20, 2022	10:00	50	65	43	37
Thursday, January 20, 2022	11:00	49	67	40	36
Thursday, January 20, 2022	12:00	50	68	41	38
Thursday, January 20, 2022	13:00	52	71	43	39
Thursday, January 20, 2022	14:00	51	65	41	36
Thursday, January 20, 2022	15:00	53	69	44	38
Thursday, January 20, 2022	16:00	54	73	46	40
Thursday, January 20, 2022	17:00	54	73	49	41
Thursday, January 20, 2022	18:00	53	69	49	41
Thursday, January 20, 2022	19:00	52	69	47	36
Thursday, January 20, 2022	20:00	52	65	46	38
Thursday, January 20, 2022	21:00	50	71	42	35
Thursday, January 20, 2022	22:00	50	72	40	34
Thursday, January 20, 2022	23:00	50	68	39	33

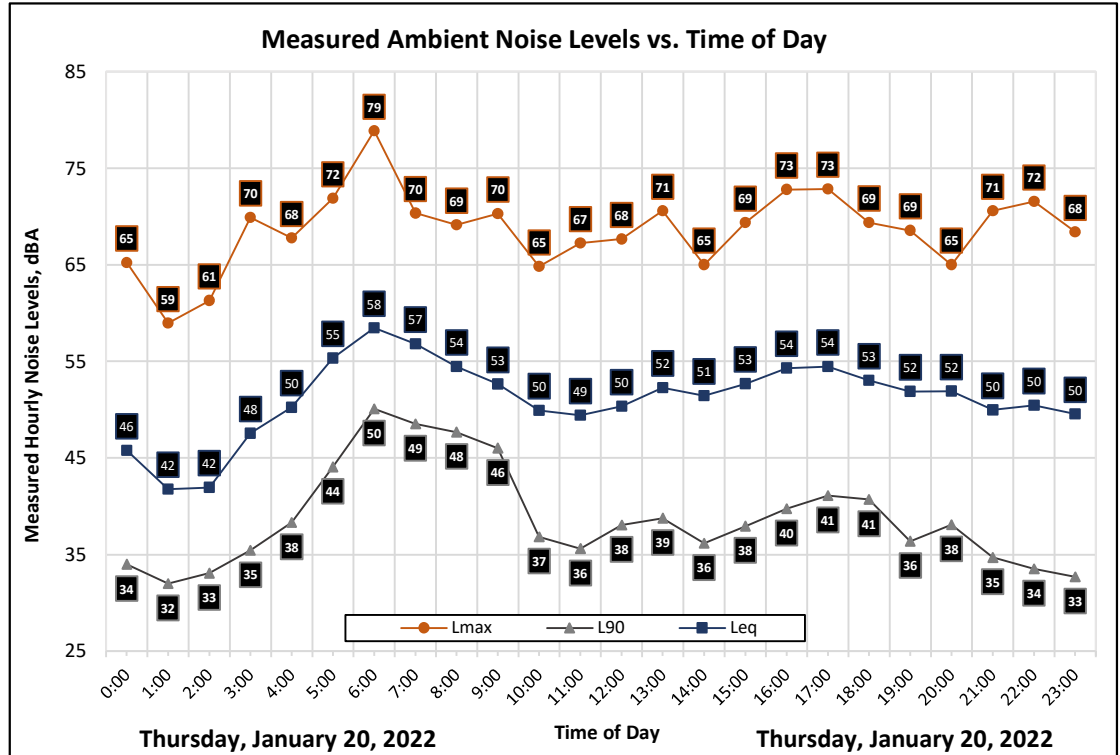

Statistics	Leq	Lmax	L50	L90
Day Average	53	69	46	40
Night Average	52	68	43	37
Day Low	49	65	40	35
Day High	57	73	54	49
Night Low	42	59	37	32
Night High	58	79	55	50
Ldn	58	Day %	68	
CNEL	59	Night %	32	



**Appendix B3: Continuous Noise Monitoring Results**

Site: LT-3

Project: Garden Hwy & Tudor Rd Parking

Meter: LDL 820-7

Location: Northwestern Project Boundary - Site 3

Calibrator: CAL200

Coordinates: 38.9984448°, -121.6099130°

Date	Time	Measured Level, dBA			
		L <sub>eq</sub>	L <sub>max</sub>	L <sub>50</sub>	L <sub>90</sub>
Thursday, January 20, 2022	0:00	43	68	37	33
Thursday, January 20, 2022	1:00	42	63	38	31
Thursday, January 20, 2022	2:00	41	58	37	33
Thursday, January 20, 2022	3:00	45	66	39	35
Thursday, January 20, 2022	4:00	47	65	42	37
Thursday, January 20, 2022	5:00	51	66	45	41
Thursday, January 20, 2022	6:00	56	74	52	47
Thursday, January 20, 2022	7:00	55	70	53	51
Thursday, January 20, 2022	8:00	56	73	55	52
Thursday, January 20, 2022	9:00	55	74	50	48
Thursday, January 20, 2022	10:00	52	75	48	47
Thursday, January 20, 2022	11:00	48	64	45	43
Thursday, January 20, 2022	12:00	48	64	45	43
Thursday, January 20, 2022	13:00	50	67	46	44
Thursday, January 20, 2022	14:00	50	62	49	43
Thursday, January 20, 2022	15:00	48	65	46	38
Thursday, January 20, 2022	16:00	47	62	44	35
Thursday, January 20, 2022	17:00	50	62	46	37
Thursday, January 20, 2022	18:00	48	67	42	37
Thursday, January 20, 2022	19:00	49	67	43	36
Thursday, January 20, 2022	20:00	49	65	41	37
Thursday, January 20, 2022	21:00	46	67	40	33
Thursday, January 20, 2022	22:00	45	63	37	34
Thursday, January 20, 2022	23:00	44	64	36	32

Statistics	Leq	Lmax	L50	L90
Day Average	51	67	46	42
Night Average	49	65	40	36
Day Low	46	62	40	33
Day High	56	75	55	52
Night Low	41	58	36	31
Night High	56	74	52	47
Ldn	56	Day %		75
CNEL	56	Night %		25

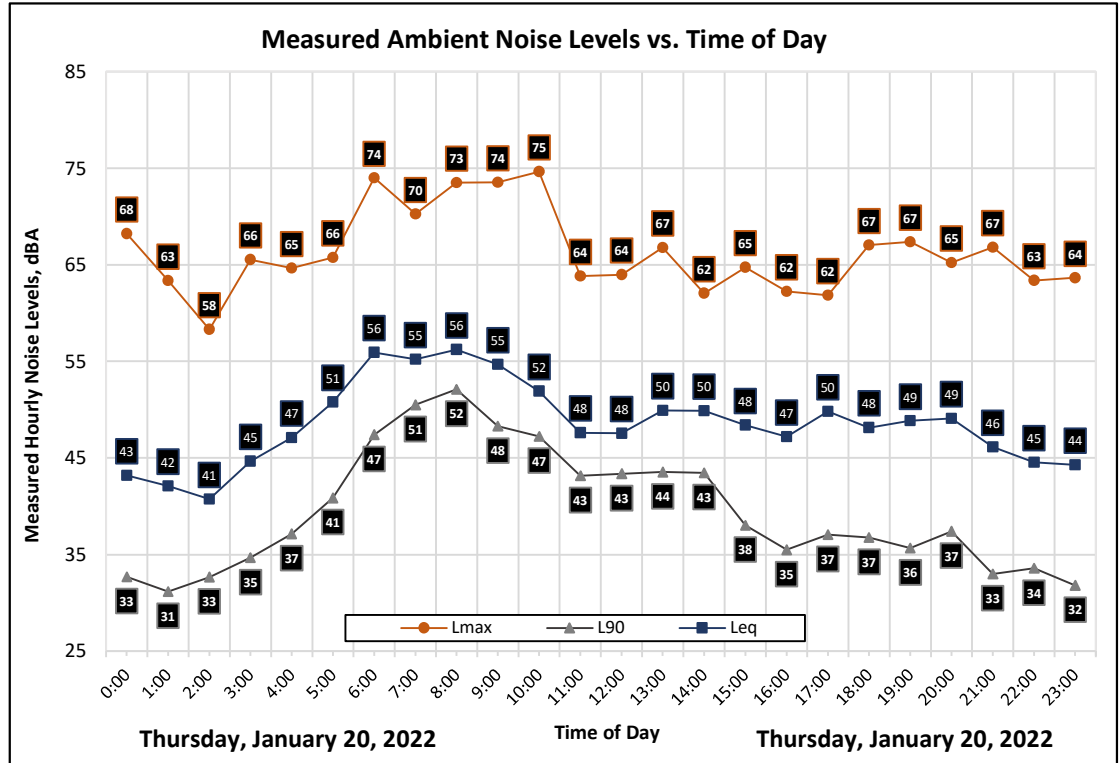

APPENDIX D  
TRANSPORTATION IMPACT ANALYSIS

**CEQA TRANSPORTATION IMPACT ANALYSIS AND  
TRAFFIC OPERATIONAL ASSESSMENT**

**FOR**

**THREE TRUCK PARKING FACILITIES ON  
TUDOR ROAD AND GARDEN HIGHWAY**

Sutter County, California

*Prepared For:*

**JOVAN ORCHARDS**

1728 Regency Way  
Yuba City, CA 95993

*Prepared By:*

**KD Anderson & Associates, Inc.**

3853 Taylor Road, Suite G  
Loomis, CA 95650  
(916) 660-1555

March 4, 2022

4180-01

Jovan Tudor Road Truck Parking.rpt

*KD Anderson & Associates, Inc.*

Transportation Engineers

**CEQA TRANSPORTATION IMPACT ANALYSIS AND TRAFFIC OPERATIONAL  
ASSESSMENT FOR THREE TRUCK PARKING FACILITIES ON  
TUDOR ROAD AND GARDEN HIGHWAY**  
Sutter County, California

**TABLE OF CONTENTS**

---

---

<b>INTRODUCTION.....</b>	<b>1</b>
<b>BACKGROUND INFORMATION.....</b>	<b>2</b>
Existing Facilities / Background Traffic Operating Conditions .....	2
Regulations / Standards .....	4
<b>DESCRIPTION OF PROPOSED PROJECTS.....</b>	<b>8</b>
Three Sites.....	8
Project Travel Characteristics.....	8
<b>PROJECT IMPACTS UNDER CEQA.....</b>	<b>10</b>
Vehicle Miles Traveled (VMT) Impact.....	10
Impacts to Other Transportation Modes.....	13
Safety Impacts to Caltrans Facilities .....	13
<b>TRAFFIC OPERATIONAL ANALYSIS.....</b>	<b>14</b>
Effects based on Daily Traffic Volumes and Level of Service .....	14
Effects Based on Intersection LOS.....	16
Traffic Signal Warrants .....	16
Site access .....	16
<b>CUMULATIVE TRAFFIC OPERATIONS.....</b>	<b>19</b>
Background .....	19
<b>APPENDIX.....</b>	<b>22</b>

**KDA**

**CEQA TRANSPORTATION IMPACT ANALYSIS AND TRAFFIC OPERATIONAL  
ASSESSMENT FOR THREE TRUCK PARKING FACILITIES ON  
TUDOR ROAD AND GARDEN HIGHWAY**  
Sutter County, California

**INTRODUCTION**

This report addresses the CEQA transportation impacts and traffic operational effects of three separate Truck Parking Facilities proposed in the Tudor Industrial / Commercial area near the Tudor Road / Garden Highway intersection in Sutter County, CA. The proposed projects will occupy a total of 20± acres and provide parking for up to 325 truck-trailer combinations. Figure 1 locates the projects and Figures 2 thru 4 are the project site plans. Figures are located in the appendix.

The analysis which follows addresses specific questions from Sutter County following their review of the three projects that are addressed in a CEQA Transportation Impact analysis and a focused Traffic Analysis Report (TAR). These questions include:

1. What types of trucks will be using the site, and if STAA trucks are anticipated, is the route to and from SR 99 legally adequate for these vehicles?
2. At what time and in what number will trucks be leaving and arriving at the proposed facilities daily?
3. What are the effects on mainline Tudor Road and Garden Highway traffic created by project's truck traffic, and are improvements to the site access beyond those proposed with each site needed?
4. What are the effects of the three projects on adjoining State Route 99?
5. What are the cumulative effects of all three projects operating together?
6. Do the project's effects comply with Sutter County General Plan policies and zoning code requirements for access improvements?
7. What are the impacts of these projects under the California Environmental Quality Act (CEQA) on regional Vehicle Miles Traveled (VMT)?

## BACKGROUND INFORMATION

### Existing Facilities / Background Traffic Operating Conditions

The text which follows describes the circulation system in the area of these projects.

**State Route 99 (SR 99).** SR 99 is a generally four-lane conventional highway with a continuous center striped median. However, access at the Tudor Road (State Route 113) junction is provided at grade separated interchange. The most recent traffic volume counts available from the California Department of Transportation (Caltrans) indicate that in 2019 SR 99 carried an Average Annual Daily Traffic (AADT) volume of 16,700 vehicles per day south of Tudor Road and 19,950 AADT to the north. Trucks comprise about 10% of the daily volume. The posted speed limit is 65 mph.

**Tudor Road and State Route 113 (SR 113).** Tudor Road extends easterly from a point near the Sutter Bypass across SR 99 to Garden Highway. The segment between George Washington Blvd and SR 99 is also State Route 113. In the area east of SR 99 Tudor Road is designated a Rural Major Collector in Figure 6-1 of the Sutter County General Plan Mobility Element and is a two-lane facility with 12-foot travel lanes and 8-foot shoulders. Caltrans reports that State Route 113 (SR 113) carried 4,500 AADT in 2019 west of the SR 99 interchange, and of that total, trucks comprise 7% of the daily volume. While no 24 counts are available, based on peak hour traffic counts conducted for this study the daily volume is estimated to be 1,400 vehicles per day between SR 99 and Garden Highway, and 4% of that volume would be heavy trucks. Tudor Road and SR 113 are designated a Terminal Road for trucks permitted under the Surface Transportation Authority Act (STAA). That designation extends across the Garden Highway intersection into the adjoining industrial use.

**Garden Highway.** Garden Highway is a Rural Major Collector that extends north along the Feather River from a connection to SR 99 via Wilson Road into Yuba City. The portion of Garden Highway north of Wilson Road to Tudor Road is a two-lane facility with 12-foot travel lanes and 8-foot shoulders. The rural prima facie 55 mph speed limit applies.

The Sutter County General Plan EIR identified 4,280 vehicles per day on Garden Highway north of Tudor Road to O'Banion Road. While 24-hr counts are not available south of Tudor Road, Caltrans traffic counts at the SR 99 / Wilson Road interchange on March 5, 2020 indicated that the volume east of SR 99 from 6:00 a.m. to 9:00 p.m. was 1,025 vehicles, and the daily traffic volume would be estimated to be about 1,100 vehicles per day based on that data. Of the observed volume, 38 vehicles were heavy trucks, or about 4% of the total volume.

That daily volume estimate would be consistent with the results of peak hour traffic counts at the Garden Highway / Tudor Road intersection completed for this study. A combined total of 219 vehicles used Garden Highway south of Tudor Road in the two peak hours, and the estimated daily volume is 1,400 vehicles per day. A total of 24 heavy trucks and 475 total vehicles were observed on Garden Highway south of Tudor Road during the four hours that were counted. Trucks were 5% of that total.

Sutter County is in the process of applying for STAA terminal route designation for the portion of Garden Highway from the Tudor Road intersection south to Wilson Road and the westerly along Wilson Road to SR 99. Preliminary response from Caltrans suggest that improvements would be needed to allow STAA trucks onto Wilson Road.

**SR 99 / Tudor Road (SR 113) interchange.** This grade separated interchange is configured as a diamond for SB ramps traffic and a partial clover-leaf for the NB SR 99 ramps. The SB ramps intersection has a two-lane approach controlled by a stop sign, and the off-ramp extends for 1,200 feet to the gore point on mainline SR 99. The eastbound approach has a separate right turn lane, and the SB on ramp is 2,000 feet long. The westbound Tudor Road approach has a separate left turn lane that is 390 feet long. The intersection is illuminated by streetlights on two corners. The NB ramps intersection is controlled by a stop sign on the single lane off ramp, and the ramp extends for 1,500 feet to mainline SR 99. The eastbound approach has a separate right turn lane onto the loop to NB SR 99. The westbound approach has separated right turn lane that extends through the intersection to a direct connection ramp onto NB SR 99. The on-ramp continues for 1,600 feet beyond Tudor Road to the mainline connection. There are no sidewalks in the vicinity of the interchange, but full-width shoulders extend across the structure. The intersection and ramps are illuminated.

Caltrans also publishes traffic count data for interchange ramps, and current daily traffic volumes are noted in Table 1. As indicated, the volumes on the ramps leading to and from the project (i.e., NB SR 99 off ramp, WB on ramp to NB SR 99 and SB SR 99 on - off ramps are all very low, (i.e., < 500 vehicles per day). While the SB off ramp carries more total traffic, nearly all of that volume turns right onto WB SR 113.

Direction	Ramp	Annual Average Daily Traffic (AADT)		
		2016	2017	2019
NB	Off to Tudor Road	230	228	265
	On from WB Tudor Road	220	-	203
	On from EB SR 113	1,580	1,405	1,429
SB	Off to Tudor Road / SR 113	2,100	1,909	1,965
	On from Tudor Road	400	404	459

**SR 99 / Wilson Road Intersection.** The Wilson Road intersection on SR 99 is controlled by a traffic signal. Separate left turn lanes are provided on SR 99 in both directions, and a northbound right turn lane onto Wilson Road is available. The eastbound Wilson Road approach is configured with a separate left turn lane and combined thru+right turn lane. The westbound Wilson Road approach has dual left turn lanes and combined thru+right turn lane. While crosswalks are not marked, the intersection has pedestrian indications and push buttons one each corner, and accessible ramps are available. The intersection is illuminated.

**Tudor Road / Garden Highway intersection.** The intersection is controlled by an all-way stop, and auxiliary turn lanes are available. The southbound approach has separate left turn and right turn lanes, and the right turn lane is outside of the stop control (i.e., yield). The northbound approach has a separate 200 foot long left turn lane. The westbound and eastbound Tudor Road approaches are single lanes. There are no sidewalks at the intersection, and no crosswalks are marked. The intersection is not illuminated.

**Peak Hour Traffic Volumes.** New a.m. and p.m. peak hour traffic counts at study area intersections are presented in Figure 5 (trucks only) and Figure 6 (all vehicles).

## **Regulations / Standards**

### **State of California**

**California Environmental Quality Act (CEQA) - SB 743.** With the adoption and 2020 implementation of SB 743, CEQA analysis of transportation impacts has moved from analysis of motorist delay based on Level of Service to consideration of a project's contribution to global climate change as expressed in terms of Vehicle Miles Traveled (VMT). While capacity analysis and Level of Service can still be considered by local agencies in addressing General Plan consistency, Level of Service is no longer a CEQA topic.

**State of California Department of Transportation (Caltrans).** Caltrans has jurisdiction over state highways. Caltrans' policy documents and analysis guidelines provide direction for transportation impact analysis.

**Highway Design Manual, 7<sup>th</sup> Edition (HDM).** The HDM establishes uniform policies and procedures to carry out the state highway design functions of the California Department of Transportation. The HDM establishes uniform policies and procedures to carry out the state highway design functions of the Department. It is neither intended as, nor does it establish, a legal standard for these functions. The standards, procedures, and requirements established and discussed herein are for the information and guidance of the officers and employees of the Department. Many of the instructions given herein are subject to amendment as conditions and experience warrant. Special situations may call for deviation from policies and procedures, subject to Division of Design approval, or such other approval as may be specifically provided for in the text of the HDM.

**Truck Turning Requirements.** Large trucks (53-foot trailers) are allowed on mainline SR 113 and Tudor Road under the Surface Transportation Authorization Act (STAA), but such vehicles are not permitted on intersecting Sutter County roads unless specifically designated for their use by Caltrans and the local agency (i.e., Sutter County) through evaluation of truck turning requirements. Private access anticipating trucks of this classification, as is typically the case for long haul operations, must also have access that can accommodate those vehicles.

**Sutter County General Plan Mobility Element.** These policies of the General Plan address the issues associated with the three projects.

M 2.4 Intersection and Driveway Spacing. Maximize intersection and driveway spacing on roadways. Driveway encroachments shall be minimized in accordance with the County’s improvement standards. (M 2-B)

M 2.5 Level of Service on County Roads. Develop and manage the County roadway segments and intersections to maintain LOS D or better during peak hour, and LOS C or better at all other times. Adjust for seasonality. These standards shall apply to all County roadway segments and intersections, unless otherwise addressed in an adopted specific plan or community plan. (M 2-C/M 2-D)

M 2.6 Mitigation by New Development. Require new development projects to analyze their local traffic impacts and to construct and implement the improvements necessary to fully mitigate their local impacts to traffic capacity, structural sections, and intersection geometrics. (M 2-E)

M 2.7 Regional Improvements. Require new development projects to analyze traffic impacts on the regional transportation system (i.e., facilities that provide regional connectivity to the new development) and require a fair share contribution to regional transportation improvements. (M 2-F)

The General Plan includes roadway segment LOS thresholds based on daily volumes, as noted in Table 2. The “rural road” thresholds are applicable to Tudor Road and Garden Highway.

<b>TABLE 2 SUTTER COUNTY GENERAL PLAN ROADWAY LEVELS OF SERVICE THRESHOLDS</b>			
<b>Roadway</b>	<b>LOS C</b>	<b>LOS D</b>	<b>LOS E</b>
Rural – Two-Lane	7,000 – 10,600	10,600 – 16,300	16,400 – 25,200
Urban – Three Lane	15,330 – 17,520	17,250 – 19,700	19,700 – 21,900
Urban – Five Lane	30,660 – 35,040	35,040 – 39,420	39,420 – 43,800
Expressway – Four Lane	29,100 – 41,800	41,801 – 53,500	53,501 – 59,500
Freeway – Four Lane	33,700 – 48,400	48,401 – 60,000	60,001 – 67,400
Freeway – Six Lane	51,800 – 73,900	73,901 – 90,900	90,901 – 101,800
Source: Sutter County General Plan DEIR – Traffic Table 6.14.6			

**Sutter County Zoning Code.** The project falls under Zoning Category 3. General Truck Yards, Large. Section 1500-05-030 E. 3. e., deals with facility access and traffic study requirements.

**3. General Truck Yards, Large**

a. In addition to other noticing requirements, upon receipt of an application for a new or modified General Truck Yard, Large, notice shall be provided to all property owners of record, within one-half (1/2) mile of the proposed project property boundaries advising an application has been received, providing a summary of the application and the location where project documents can be reviewed.



- b. General Truck Yards, Large, shall comply with the applicable requirements of Table 1500 07-3 (Commercial and Employment Design Checklist).
- c. General truck Yards, Large, may only be established in the Agriculture District when located immediately adjacent to a State Highway or a designated T or S-route (STAA).
- d. Lighting shall be provided consistent with Table 1500-07-3 (Commercial and Employment Design Checklist). Light pole and fixture height shall not exceed twenty-five (25) feet. Truck parking areas shall incorporate motion activated lighting that shall not spill onto adjoining properties. A photometric plan, prepared by an appropriately licensed design professional, shall be submitted at the time of application demonstrating compliance with this requirement.
- e. Facility access shall incorporate acceleration and deceleration lanes, the criteria for which is determined by completion of a traffic study prepared to recognized engineering standards, including County Improvement Standards that shall also determine any additional needed traffic related improvements. No vehicle shall be permitted to obstruct or back onto a public roadway. Facilities shall be designed so that trucks entering and exiting yards are not required to cross the road center line into opposing traffic. The traffic study shall be submitted at the time application is made to the Development Services Planning Division for the proposed use.
- f. Facilities located along a State Highway shall comply with the California Department of Transportation standards for roads, freeway entrances, sight distance and turning radius.
- g. Driveways shall be a minimum of forty (40) feet in width measured at the public right-of way or as deemed necessary by the Road Commissioner. Driveways shall be designed to allow trucks to enter and exit a facility without entering into opposing lanes of traffic.
- h. When proposed, access gates shall be setback a minimum of sixty-five (65) feet, or a sufficient distance, from the public right-of-way to allow trucks with trailers to completely exit the roadway when gates are closed.
- i. All maneuvering and parking areas for automobiles, trucks and trailers shall be located onsite and shall be paved and maintained consistent with Article 20. No parking or maneuvering for parking shall occur in a public road right-of-way. Wheel stops shall be provided for both automobile and truck parking areas to protect fencing, landscaping, structures and adjacent properties. The County may require operators to re-surface deteriorated asphalt areas and such work shall be completed within 180-days of the County making a request or by a mutually agreed time as approved by the Director. At his or her discretion, the Director may require the installation of wheel washing facilities or other measures necessary to eliminate impacts to the County road system.
- j. 1. When located outside a designated floodplain, permanent bathroom facilities (not portable toilets) shall be established onsite and shall be accessible during hours of operation and shall not be visible from the public right of way. Bathroom facilities shall include, at a minimum, a flushing toilet and a handwashing station and shall be serviced, as needed, on a regular basis. Bathrooms shall be provided at a minimum ratio of one (1) restroom per twenty-five (25) trucks or as otherwise determined by the Director."
2. When located in a designated floodplain, portable trailer mounted bathroom facilities may be established onsite and shall be accessible during hours of operation and shall not be visible from the public right of way. Bathroom facilities shall include, at a minimum, a toilet and handwashing station. Facilities shall be serviced, as needed, on a regular basis. The County may require an operator to document through a contract, or other means deemed sufficient, that bathroom facilities are being properly maintained. Bathrooms shall be provided at a minimum ratio of one (1) restroom per twenty-five (25) trucks or as otherwise determined by the Director.
- k. The minimum usable sewage disposal area shall be barricaded or have access physically restricted to prevent vehicles from driving or parking over it.
- l. A drainage plan, consistent with the County Improvement Standards, shall be submitted at the time application is made, demonstrating runoff resulting from site development will not adversely impact

surrounding property owners, or public rights-of-way. Drainage from parking areas shall utilize best available technology to minimize pollution and shall comply with State law.

m. Materials including truck parts, tires and related items, shall be contained inside a building, and in accordance with applicable State law. If a General Truck Yard, Large, proposes to conduct onsite repairs, such work shall occur within a building approved for said work. This requirement shall not apply to windshield, wiper, or truck headlight replacement work. A maximum of two inoperable trucks may be kept onsite for rebuilding or parts and shall be contained in a designated area, surfaced with concrete and designed to contain spilled fluids, and shall be located so as not to be visible from a public right of way or neighboring properties.

n. Truck and/or trailer maintenance, repair, and proper handling and disposal of hazardous materials shall comply with the requirements of the Development Services Department and applicable State law.

o. Facilities shall be screened from public view, roadways and adjoining, non-employment zoned, land through concrete masonry unit walls or chain-link fencing with privacy slats, having a minimum privacy rating of 90 percent or greater, and landscaping. All walls, fencing and landscaping shall be continuously maintained, and the Director may require replacement to damaged items.

p. Fifty-five (55) gallon trash waste receptacles, or equivalent, shall be provided at a minimum ratio of one (1) receptacle per five (5) trucks and shall be conveniently located in the truck/trailer parking area to facilitate their use. The County may allow other means of trash collection and control as appropriate.

q. Truck engine idling shall occur consistent with State law and compliance with this requirement shall be included as a project condition.

r. The operation of Transportation refrigeration units shall occur consistent with California Code of Regulations, Title 13, Division 3, Chapter 9, Article 8 commencing at Section 2477 or as amended.

s. At the time application is made, a plan shall be submitted demonstrating how undeveloped areas shall be maintained to prevent the creation of dust, erosion and shall not become a health hazard or create a public nuisance.

t. The County will consider as part of its review, indirect sources of traffic, noise and pollution, such as service trucks and passenger vehicles visiting facilities.

u. The County will consider requiring permanent onsite landscape setback buffers from existing adjacent residences, to be maintained by the property owner, to the extent feasible, for new or expanded facilities.

## DESCRIPTION OF PROPOSED PROJECTS

### Three Sites

This assessment addresses three separate truck parking sites that are summarized in Table 3 and were identified in Figure 1, and Figures 2-4.

#	Location	Acres $\pm$	Truck / Trailer Parking Spaces
1	848 Tudor Road	1.5	19
2	Garden Highway @ Ashford Avenue	11.5	202
3	Garden Highway @ Peck Avenue	7.0	104
	Total	20.0	325

### Project Travel Characteristics

**Type of Operation.** The operational characteristics of the project have been identified in terms of the amount of truck and automobile activity and the time periods of that travel. Typically, trucking operations fall into two categories: “Long haul” or “Local Distribution or Agricultural Harvesting / Processing Support”. For long haul trucks the typical routine sends drivers away from the site for extended periods of time. On a typical weeklong haul, most trucks return to the site on Friday and leave early Sunday or Monday, and most drivers try to operate outside peak traffic hours. Trips to the east coast can take longer. During the week some trucks may come and go for inspection or maintenance or if the drivers have to come home during the week. Alternatively, local based trucking typically leaves the site each weekday and returns that afternoon /evening. In both cases, a driver would travel by automobile to and from the site before beginning or ending his trips. Some of the truck drivers would park their personal auto at the site and others would be dropped off.

**Trip Generation.** This project’s trip generation was estimated based on available resources and our understanding of the characteristics of these uses. You have indicated that this site will be used by long haul truckers.

Long haul truck trip generation rates were developed from 24-hr truck traffic counts at a large (440 spaces) truck parking area in Yuba City. That site generated 334 total truck trips (143 in and 191 out) on a Thursday, or 7.6 daily truck trips per 10 spaces. It was assumed that drivers would generate automobile trips at the same time that trucks entered and exited and that ½ of the drivers would be dropped off / picked up.

Alternatively, for local trucks it would be assumed that all would move to and from the site each day, or 20 daily truck trips per 10 spaces. Typically, much local truck activity begins in the morning before the typical commute hour, and trucks return outside of the p.m. peak hour. For this analysis

we have assumed that 1/3 of the local trucks will travel to and from the site during peak hour, and that 1/2 of the drivers will be dropped off / picked up.

Assuming the truck at each site are all long haul the projects result in the daily and peak hour trip generation forecasts presented in the attached Tables A thru C in the appendix. As shown below in Table 4, all together, the three sites could generate 248 daily truck trips (i.e., 1/2 inbound and 1/2 outbound), and each day 373 automobile trips would be expected, for a total of 621 daily trips by vehicles of all types.

<b>TABLE 4 TRIP GENERATION ESTIMATES</b>					
#	Location	Spaces	Trips		
			Truck	Auto	Total
<i>Peak Hours</i>					
1	848 Tudor Road	19	1	2	3
2	Garden Highway @ Ashford Rd	202	11	17	28
3	Garden Highway @ Peck Rd	104	6	9	15
	All three sites	325	18	28	46
<i>Daily</i>					
1	848 Tudor Road	19	15	22	37
2	Garden Highway @ Ashford Rd	202	154	231	385
3	Garden Highway @ Peck Rd	104	79	120	199
	All three sites	325	248	373	621

**Trip Distribution.** Long haul trucks in the area typically follow routes along I-5, SR 99 or I-80, and SR 99 would be used to reach these routes. This analysis assumes that truck traffic is split 50% north of SR 99 and 50% on SR 99 to the south.

Automobile trips would generally be made between truck parking and the residences of drivers. In this case, the distribution of these trips would be based on the distribution of residences in the south Sutter County / north Sacramento County region. This analysis assumes 55% north on SR 99, 10% north on Garden Highway, 10% west on SR 113 and 25% south on SR 99.

**Traffic Assignments.** Caltrans has determined that an STAA Terminal route designation can be extended south on Garden Highway from the current Tudor Road terminus to the southern project access. The designation will not extend beyond the access to Wilson Road. Therefore all truck traffic has been assumed to use Tudor Road to the SR 99 interchange. The individual assignments of trucks and total vehicles for each of the three site is presented in the appendix. The cumulative truck traffic associated with all three projects is presented in Figure 7, while the cumulative total for all vehicles (i.e., automobiles and trucks) of all three projects is shown in Figure 8.

## PROJECT IMPACTS UNDER CEQA

The purpose of this analysis is to identify potential transportation impacts under the requirements of the California Environmental Quality Act (CEQA) as well as traffic operational effects as they relate to the introduction of project automobile and truck traffic on state highways. CEQA impacts relating to Vehicle Miles Traveled (VMT) with regular operation of the project has been discussed within the context of screening criteria presented in Governors' Office of Planning and Research (OPR) CEQA guidance. A traffic operations analysis was also conducted to identify the project's effects on state highway safety and with regards to Sutter County General Plan policies.

### Vehicle Miles Traveled (VMT) Impact

SB 743 requires the Governor's Office of Planning and Research (OPR) to identify new metrics for identifying and mitigating transportation impacts within CEQA. For land use projects, OPR identified Vehicle Miles Traveled (VMT) per capita, VMT per employee, and net VMT as new metrics for transportation analysis. The CEQA Guidelines state that lead agencies, such as Sutter County, may establish "thresholds of significance" to assist with the determination of significant impacts of a project. The CEQA Guidelines generally state that projects that decrease VMT can be assumed to have a less than significant transportation impact. The CEQA Guidelines do not provide any specific criteria on how to determine what level of project VMT would be considered a significant impact.

The extent to which VMT analysis is applicable to this project has been considered from several perspectives is discussed in the materials which follow.

**Vehicle Types.** OPR guidance notes that CEQA VMT analysis is intended to focus on passenger vehicles.

Proposed Section 15064.3, subdivision (a), states, "For the purposes of this section, 'vehicle miles traveled' refers to the amount and distance of automobile travel attributable to a project." Here, the term "automobile" refers to on-road passenger vehicles, specifically cars and light trucks.

OPR guidance allows Heavy-duty truck VMT to be included for modeling convenience and ease of calculation (for example, where models or data provide combined auto and heavy truck VMT).

**Methods and Significance Criteria.** The OPR *Technical Advisory* provides general direction regarding the methods to be employed and significance criteria to evaluate VMT impacts, absent policies adopted by local agencies. The directive addresses several aspects of VMT impact analysis, and is organized as follows:

- **Screening Criteria:** Screening criteria are intended to quickly identify when a project should be expected to cause a less-than-significant VMT impact without conducting a detailed study.
- **Significance Thresholds:** Significance thresholds define what constitutes an acceptable level of VMT effect and what could be considered a significant level of VMT effect requiring mitigation.

- **Analysis Methodology:** These are the potential procedures and tools for producing VMT forecasts to use in the VMT impact assessment.
- **Mitigation:** Projects that are found to have a significant VMT impact based on the adopted significance thresholds are required to implement mitigation measures to reduce impacts to a less than significant level (or to the extent feasible).

**Screening Criteria.** Screening criteria can be used to quickly identify whether sufficient evidence exists to presume a project will have a less than significant VMT impact without conducting a detailed study. However, each project should be evaluated against the evidence supporting that screening criteria to determine if it applies. Under OPR guidance projects meeting at least one of the criteria below can be presumed to have a less than significant VMT impact, absent substantial evidence that the project will lead to a significant impact.

- **Small Projects:** Defined as a project that generates 110 or fewer average daily vehicle trips.
- **Affordable Housing:** Defined as a project consisting of deed-restricted affordable housing.
- **Local Serving Retail:** Defined as retail uses of 50,000 square feet or less can be presumed to have a less than significant impact.
- **Proximity to High Quality Transit.** The directive notes that employment and residential development located within ½ mile of a high-quality transit corridor offering 15 minute headways can be presumed to have a less than significant impact.

**Screenline Evaluation.** The extent to which the VMT impacts of the three projects can be presumed to be less than significant has been determined based on review of the OPR directive’s screening criteria and general guidance.

The OPR **Small Project** criteria is applicable to one of the three projects. The regular operation of the Tudor Road project with 19 spaces is projected to result in 22 daily automobile trips. As the 110 ADT threshold for automobiles is not exceeded, that project’s VMT impacts can be presumed to be less than significant.

The Garden Highway at Peck Lane project with 104 spaces is projected to generate 120 daily automobile trips, while the Garden Highway at Ashcroft Lane project is projected to generate 231 daily automobile trips. Neither project can be classified as a “small project”.

The project cannot be addressed by other screen line criteria identified by OPR. The project is not an **Affordable Housing** development or **Locally Serving Retail** use.

**Projects in Low VMT-Generating Area.** Under OPR Guidelines a residential or office project that is in a VMT efficient area based on an available VMT Estimation Tool. The project must be consistent in size and land use type (i.e., density, mix of uses, transit accessibility, etc.) as the surrounding built environment.

The Sacramento Area Council of Governments (SACOG) has identified **Low VMT generating locations** within this region, including the unincorporated Sutter County area. The two Garden Highway truck parking project’s location within SACOG region was determined, and the per employee VMT characteristics of the businesses in this area of Sutter County was identified. There

is no SACOG report for the immediate area of the projects. However, the commercial areas in the general vicinity all exhibit high “per job” VMT that exceed both the SACOG regional average and the average for unincorporated Sutter County. As a result, these project’s regional VMT impact cannot be presumed to be less than significant simply based on location, and additional assessment is required.

**Additional VMT Assessment.** Because the project’s impact cannot be screened out, additional assessment was performed. The project’s VMT impacts have been assessed with regards to the actual characteristics of the activities that generate automobile VMT. As noted earlier, automobile trips would be generated as truck drivers move to and from the site and their homes, either using their personal vehicle or being dropped off. Because the project’s spaces would be rented to individual truckers who would be inclined to park near their residence, it is possible to estimate project VMT based on the forecasted daily trip generation and the average distance to area residences based on the trip distribution assumptions made earlier.

As noted in Table 5, a weighted average distance from the project area to residences in the assumed trip distribution pattern was identified for each project and applied to the daily trip generation forecasts. In turn, the VMT forecasts were divided by the number of jobs (i.e., spaces) to develop “per job” VMT. Those values were then compared to the average VMT rate that would meet a 15% VMT reduction goals for unincorporated Sutter County.

As shown, the average automobile VMT per job for the three projects ranges from 19.0 to 19.4. As a comparison the average VMT satisfying the overall Sutter County VMT reduction goal is 23.3. Because the projects’ average rates are less than the goal, their VMT impacts are not significant.

TABLE 5 VEHICLE MILES TRAVELED (VMT) ESTIMATES						
#	Location	Spaces	Daily Auto Trips	Average Distance (miles)	Vehicle Miles Traveled (VMT)	VMT per job
1	848 Tudor Road	19	22	16.39 <sup>1</sup>	360.6	19.0
2	Garden Highway @ Ashford Road	202	231	16.70 <sup>2</sup>	3,857.7	19.1
3	Garden Highway @ Peck Road	104	120	16.80 <sup>3</sup>	2,016.0	19.4
85% of average per job VMT for Unincorporated Sutter County						23.3 <sup>4</sup>
<sup>1</sup> weighted average of 55% Yuba City via SR 99 (10.9 miles), 25% Sacramento via SR 99 (32.4 miles), 10% SR 20 / George Washington Blvd (12.1 miles) and 10% Yuba City via Garden Highway (10.8 miles). <sup>2</sup> weighted average of 55% Yuba City via SR 99 (11.9 miles), 25% Sacramento via SR 99 (31.4 miles), 10% SR 20 / George Washington Blvd (13.2 miles) and 10% Yuba City via Garden Highway (10.1 miles). <sup>3</sup> weighted average of 55% Yuba City via SR 99 (12.1 miles), 25% Sacramento via SR 99 (33.2 miles), 10% SR 20 / George Washington Blvd (13.3 miles) and 10% Yuba City via Garden Highway (10.4 miles). <sup>4</sup> 85% of current average for unincorporated Sutter County (27.41VMT x .85 = 23.3 VMT per job).						

## **Impacts to Other Transportation Modes**

**Pedestrian Facilities.** There are few developed areas around the project to create pedestrian travel to and from the site. Any pedestrians would use the roadway shoulder or edge of pavement, as would be the case for any current pedestrians visiting any existing business the area. As the number of additional vehicle trips caused by the project is low and few if any pedestrians are likely, the project's impact to pedestrian facilities is not significant, and mitigation is not required.

**Bicycle Facilities.** The same issues affecting pedestrian travel also affect bicycles. The project's distance to potential employee residences is too far to make bicycling a feasible option, the project's limited trip generation would not result in any new vehicle / bicycle conflicts or exacerbate current deficiencies, and the project's impact to bicycle facilities and travel is not significant, and mitigation is not required.

**Transit.** Some employees could elect to use transit service if it was convenient to the site. The closest regular Yuba-Sutter Transit stop at the SR 99 / Bogue Road intersection is about 7-8 miles away. This distance is generally beyond normal expectations for regular transit use. Because few truckers riding transit are anticipated, the project's impact on transit use based on ridership is not significant, and mitigation is not required.

## **Safety Impacts to Caltrans Facilities**

**Considerations.** While Level of Service analysis is no longer a consideration, a project's impacts to safety on Caltrans facilities remains a significance criterion under CEQA. Under current practice, safety impacts on state facilities are typically considered within the context of queuing on off-ramps and in turn lanes at intersections, truck turning requirements and the need for alternative traffic control devices. Queuing that spills over from a turn lane or extends down an off-ramp to the mainline freeway could represent significant safety issues. Intersections where truck paths leave the pavement or encroach into opposing lanes are a safety issue. Operation of an intersection with inappropriate traffic control devices would also represent a potential safety issue.

**Evaluation.** The project could add a small amount of automobile and truck traffic through the SR 99 / SR 113 – Tudor Road interchange. However, because current traffic volumes are low that small increase would not result in any appreciable increase in queuing that might cause a safety issue as it relates to mainline SR 99. While the ramp terminal intersections are currently stop controlled, the addition of project traffic would not result in the need for signalization at these low volume levels.

The project would add truck traffic turning at the intersections at the SR 99 / SR 113 / Tudor Road interchange. However, the interchange is already handling heavy trucks that are permitted under STAA. STAA trucks are not permitted at the SR 99 / Wilson Road intersection, and the pending STAA designation being pursued by Sutter County would only link Tudor Road with the project site. Thus, the project does not result in a situation where truck turns cause a safety impact.

Overall, the project's impact to safety on state facilities is not significant, and mitigation is not required.

## TRAFFIC OPERATIONAL ANALYSIS

This report section addresses the traffic operational effects of the three projects within the context of Sutter County General Plan policies and the adequacy of site access.

### **Effects based on Daily Traffic Volumes and Level of Service.**

**Traffic Volumes.** Table 6 presents the daily traffic volume contribution (i.e., trucks and automobiles) of the three projects to study area roads, as well as the sum of project trips and current traffic volumes.

**Plus Project Levels of Service.** As shown, the addition of project trips does not change the current Level of Service on any road. All roadways operate at LOS B, which satisfies the General Plan's minimum requirement, and will continue to do so with the addition of project trips.

**TABLE 6  
PROJECT TRAFFIC EFFECTS BASED ON DAILY TRAFFIC VOLUME**

Location	LOS C Threshold	Existing		Existing Plus Project Conditions			
		Daily Volume	LOS	#	Daily Volume		LOS
					Project Only	Total	
Tudor Road from SR 99 to 848 Tudor Road	10,600	1,400	B	1	35	1,435	B
				2	319	1,719	B
				3	163	1,563	B
				All	517	1,917	B
Tudor Road from 848 Tudor Road to Garden Hwy	10,600	1,400	B	1	2	1,402	B
				2	319	1,419	B
				3	163	1,563	B
				All	484	1,884	B
Garden Hwy from O'Banion Road to Tudor Road	10,600	4,280	B	1	2	4,182	B
				2	24	4,304	B
				3	12	4,292	B
				All	38	4,318	B
Garden Hwy from Tudor Road to Ashford Ave	10,600	1,400	B	1	0	1,400	B
				2	341	1,741	B
				3	175	1,575	B
				4	516	1,916	B
Garden Hwy from Ashford Ave to Peck Ave	10,600	1,400	B	1	0	1,400	B
				2	44	1,444	B
				3	175	1,575	B
				4	219	1,619	B
Garden Hwy from Peck Ave to Wilson Ave	10,600	1,100	B	1	0	1,100	B
				2	44	1,144	B
				3	24	1,124	B
				4	68	1,168	B

**Effects Based on Intersection LOS**

**Volumes.** Figures 9 and 10 present “Existing plus all 3 Projects” traffic volumes (i.e., trucks only and all vehicles).

**Levels of Service.** Table 7 presents current and “plus project” Levels of Service at the all-way stop controlled Tudor Road / Garden Highway intersection. In each case the number of heavy trucks in each movement was used to identify the truck percentage for LOS calculation. For current traffic the peak hour of truck traffic was employed for this calculation to present a “worst case” condition.

As shown, the intersections will continue to operate with Levels of Service that satisfy the General Plan’s LOS D minimum standard for peak hour conditions with and without the proposed projects.

TABLE 7 PROJECT TRAFFIC EFFECTS BASED ON INTERSECTION LEVEL OF SERVICE					
Condition	Control	Peak Hour Level of Service			
		AM Peak Hour		PM Peak Hour	
		Average Delay (sec/veh)	LOS	Average Delay (sec/veh)	LOS
Existing	AWS	7.9	A	9.0	A
Plus 848 Tudor Road		7.9	A	9.0	A
Plus Garden Hwy at Ashcroft Ave		7.9	A	9.1	A
Plus Garden Hwy at Peck Ave		7.9	A	9.0	A
Plus All 3		8.1	A	9.1	A

**Traffic Signal Warrants**

Peak hour traffic volumes at the Tudor Road / Garden Highway intersection were reviewed to determine whether the addition of project traffic may cause volumes to reach a level that satisfied traffic signal warrants. With all three projects, anticipated volumes fall below those required that satisfied Warrant 3, Peak Hour Volume.

**Site access**

Anticipated traffic volumes and truck turning requirements were reviewed at the site access to determine whether proposed improvements are adequate or additional improvements are justified.

**Sight Distance.** The alignment of Tudor Road and Garden Highway in this area is level and straight. As a result, the view measured 15 feet from the edge of the travel way would satisfy Caltrans Minimum Sight Distance (Table 201.1 500 feet at 55 mph) Corner Sight Distance (Table 405.1a 925 feet at 55 mph) ) requirements in both directions.

**Proposed Access Evaluation.** All three plans providing access treatments.

**848 Tudor Road Truck Yard.** The driveway at 848 Tudor Road already exists. The standard 8 foot paved shoulder has been widened to 14 feet beginning about 25 feet west of the 27 foot wide driveway and continuing to the east for about 500 feet. Curb returns are also provided.

Functionally, the current layout provides the pavement width needed to allow eastbound trucks to move out of the through travel lane before they reach the driveway width. However, the path of a truck entering the site that has been shown on the project site plan does not make use of the widened shoulder area, and the turn is made from the through travel lane. That drawing suggests that entering and exiting trucks would occupy most of the driveway when accessing the site. While this layout does not provide formal acceleration and deceleration lanes, such features are not judged to be necessary because the potential for conflicts with following vehicles is very low due to the very low number of trucks at the site and the low background traffic volume on Tudor Road. In addition, no trucks are likely to leave the site by turning right.

**Garden Highway at Ashcroft Avenue.** The proposed access features large radius (65 foot) corner returns. The site plan provided by the site civil engineer illustrates that the layout would allow trucks to access the site in all directions without interfering with a vehicle headed in the other direction. The layout proposes no shoulder widening nor construction of separate acceleration or deceleration lanes as required by the zoning code. Functionally, the large radius corners will allow trucks to enter the site without slowing to a crawl or stopping to wait for a conflicting vehicle. The driveway is about 900 feet from the All-way Stop at Tudor Road. Based on typical truck acceleration and deceleration rates a truck would exit the intersection and accelerate to about 35 mph before beginning to slow to enter the site when turning right.

The project is expected to create eight inbound truck trips during the weekday p.m. peak hour, or one every 7.5 minutes. While a following motorist may occasionally be delayed by a truck slowing to turn right, because background traffic volumes on Garden Highway are low, a separate deceleration treatment does not appear justified. Because truck traffic is most likely to exit by turning left due to the absences of STAA designation to the south, an acceleration lane is not justified.

**Garden Highway at Peck Avenue.** The proposed access at Peck Avenue is similar to that provided at Ashcroft Avenue and features large radius (65 foot) corner returns. The site plan provided by the site civil engineer illustrates that the layout would allow trucks to access the site in all directions without interfering with a vehicle headed in the other direction. The layout proposes no shoulder widening nor construction of separate acceleration or deceleration lanes as required by the zoning code. Functionally, the large radius corners will allow trucks to enter the site without slowing to a crawl or stopping to wait for a conflicting vehicle. The driveway is about 1,900 feet from the All-way Stop at Tudor Road. Based on typical truck acceleration and deceleration rates a truck would exit the intersection and accelerate to 55 mph before beginning to slow to enter the site when turning right.

Measured centerline to centerline the driveway appears to be about 160 feet and across the street from Ashcroft Avenue. As a private driveway, the access is not an “intersecting street” that is to meet separation standards under Section 4.6 of the Sutter County improvement standards. Because traffic volumes on Ashcroft Avenue are slow, the distance between intersections should be acceptable.

The project is expected to create four inbound truck trips during the weekday p.m. peak hour, or one every 15 minutes. While a following motorist may occasionally be delayed by a truck slowing to turn right, because background traffic volumes on Garden Highway are low, a separate deceleration treatment does not appear justified. Because truck traffic is most likely to exit by turning left due to the absences of STAA designation to the south, an acceleration lane is not justified.

## CUMULATIVE TRAFFIC OPERATIONS

### Background

This report section considers the effects of the three projects within the context of future background traffic conditions. Two perspectives were considered:

- Year 2040 conditions based on SACOG SacSim regional travel demand forecasting model results, and
- Year 2040 traffic volume forecasts from the Sutter County General Plan EIR Transportation and Circulation section.

**SACOG SacSim traffic model forecasts.** The SacSim model forecasts reflect land use assumptions made by its member agencies for development over the six county areas to the Year 2040. These assumptions rarely result in full buildout of individual areas but represent allocations of regional expectations for population and employment growth. While not all roadway segments have forecasts, Year 2040 daily traffic volumes based on that source are presented in Table 8.

**Sutter County General Plan Projections.** The General Plan EIR addresses “Adjusted Buildout” conditions that assume a much greater level of development in the Tudor Road Industrial area. As a result, its daily traffic volumes forecasts and volume created from its growth rates are much higher than those based on the SacSim traffic model. Daily traffic volumes presented in the EIR, are shown Table 8, as well as the equivalent growth rates derived from those volumes.

TABLE 8 YEAR 2040 BACKGROUND DAILY TRAFFIC VOLUMES FORECASTS						
Road	Location	Existing	SACSIM Model		General Plan <sup>1</sup>	
		Volume	Growth Rate	Volume	Volume	Growth Rate
<i>Background Volumes based on Original Data</i>						
Garden Hwy	O'Banion Rd to Tudor Rd	4,280	1.11	4,765	14,680	3.43
SR 113	George Washington Blvd to SR 99	4,500	1.06	4,750	2,640	0.69 <sup>2</sup>
<i>Background Volumes Interpolated from Each Source</i>						
Tudor Road	SR 99 to Garden Hwy	1,400	1.11	1,550	4,800	3.43
Garden Hwy	Tudor Rd to Wilson Rd	1,400	1.11	1,550	4,800	3.43
<sup>1</sup> General Plan EIR Table 6.14-11 Roadway Segment Levels of Service –2030 Adjusted Buildout <sup>2</sup> Growth rate derived from comparison of GP EIR’s “existing” volume of 3,850 and forecast of 2,640.						

**Evaluation.** The relative cumulative traffic effects of the three projects have been assessed within the context of future traffic volumes and General plan LOS thresholds. As noted in Tables 9 and 10, all study area roadways are forecast to continue to operate within the General Plan’s LOS C limit with and without the project.

**TABLE 9  
PROJECT TRAFFIC EFFECTS BASED ON CUMULATIVE DAILY TRAFFIC VOLUMES  
DERIVED FROM SACSIM REGIONAL TRAVEL DEMAND FORECASTING MODEL**

Location	LOS C Threshold	Year 2040 Background		Year 2040 Plus Project Conditions			
		Daily Volume	LOS	#	Daily Volume		LOS
					Project Only	Total	
Tudor Road from SR 99 to 848 Tudor Road	10,600	1,550	B	1	35	1,585	B
				2	319	1,869	B
				3	163	1,713	B
				All	517	2,067	B
Tudor Road from 848 Tudor Rd to Garden Hwy	10,600	1,550	B	1	2	1,552	B
				2	319	1,869	B
				3	163	1,713	B
				All	484	1,734	B
Garden Hwy from O'Banion Rd to Tudor Road	10,600	4,765	B	1	2	4,767	B
				2	24	4,789	B
				3	12	4,777	B
				All	38	4,803	B
Garden Hwy from Tudor Road to Ashford Ave	10,600	1,550	B	1	0	1,550	B
				2	341	1,891	B
				3	175	1,725	B
				4	516	2,066	B
Garden Hwy from Ashford Ave to Peck Ave	10,600	1,550	B	1	0	1,550	B
				2	44	1,594	B
				3	175	1,725	B
				4	219	1,769	B
Garden Hwy from Peck Ave to Wilson Avenue	10,600	1,220	B	1	0	1,220	B
				2	44	1,264	B
				3	24	1,244	B
				4	68	1,288	B

**TABLE 10  
PROJECT TRAFFIC EFFECTS BASED ON CUMULATIVE DAILY TRAFFIC VOLUMES  
DERIVED FROM SUTTER COUNTY GENERAL PLAN EIR FORECASTS**

Location	LOS C Threshold	Year 2040 Background		Year 2040 Plus Project Conditions			
		Daily Volume	LOS	#	Daily Volume		LOS
					Project Only	Total	
Tudor Road from SR 99 to 848 Tudor Road	10,600	4,800	B	1	35	4,835	B
				2	319	5,119	B
				3	163	4,963	B
				All	517	5,317	B
Tudor Road from 848 Tudor Rd to Garden Hwy	10,600	4,800	B	1	2	4,802	B
				2	319	5,119	B
				3	163	4,963	B
				All	484	5,284	B
Garden Hwy from O'Banion Rd to Tudor Road	17,520 <sup>1</sup>	14,680	B	1	2	14,682	B
				2	24	14,704	B
				3	12	14,692	B
				All	38	14,718	B
Garden Hwy from Tudor Road to Ashford Ave	10,600	4,800		1	0	4,800	B
				2	341	5,141	B
				3	175	4,975	B
				4	516	5,316	B
Garden Hwy from Ashford Ave to Peck Ave	10,600	4,800	B	1	0	4,800	B
				2	44	4,844	B
				3	175	4,975	B
				4	219	5,019	B
Garden Hwy from Peck Ave to Wilson Avenue	10,600	3,800	B	1	0	3,800	B
				2	44	3,844	B
				3	24	3,824	B
				4	68	2,868	B

<sup>1</sup> Roadway improved to urban three—lane in GP EIR

**APPENDIX**

Figures 1-10  
Tables A-C  
Traffic Counts  
Level of Service Calcs



VICINITY MAP

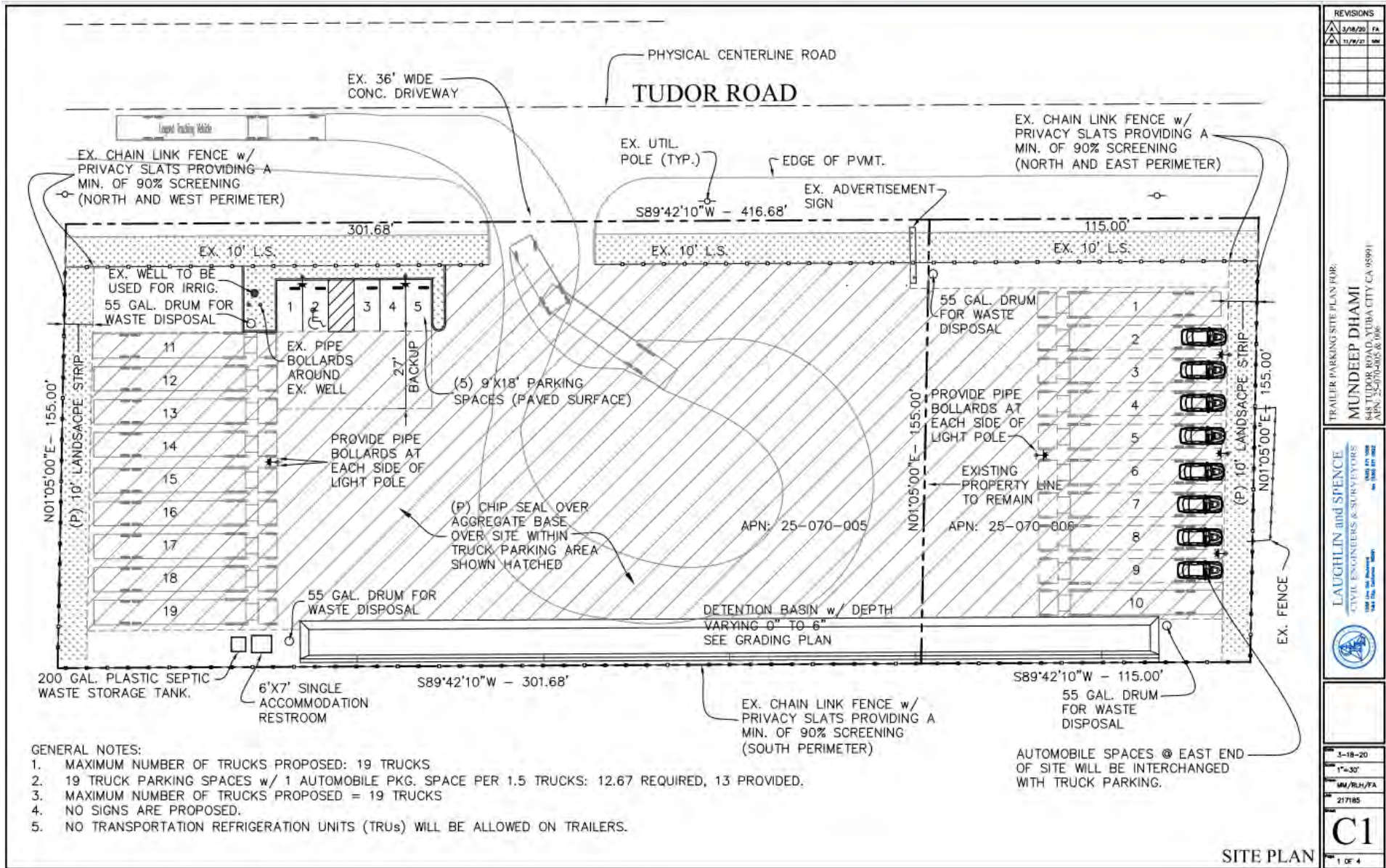



PRELIMINARY SITE PLAN

REVISIONS	
△	-
△	-
△	-
△	-

NOTE: SCALE BAR IS ONE INCH ON ORIGINAL DRAWING. DIMENSIONS 1" IF NOT ONE INCH ON THIS SHEET, ADJUST ACCORDINGLY.

TRUCK YARD SITE PLAN FOR:  
**SABIT DHUDWAL**  
 1000 GARDEN HWY, YUBA CITY, CA 95901

**LAUGHLIN and SPENCE**  
 CIVIL ENGINEERS & SURVEYORS  
 1000 GARDEN HWY, YUBA CITY, CA 95901  
 TEL: (530) 471-1000  
 FAX: (530) 471-1002



THIS PLAN AND SPECIFICATIONS WERE PREPARED BY ME OR UNDER MY CLOSE PERSONAL SUPERVISION AND I AM A LICENSED PROFESSIONAL ENGINEER IN THE STATE OF CALIFORNIA. I HEREBY CERTIFY THAT I AM THE DESIGNER OF THIS PROJECT.

2-8-22
1"-50'
JWS
21-7191

**C1**

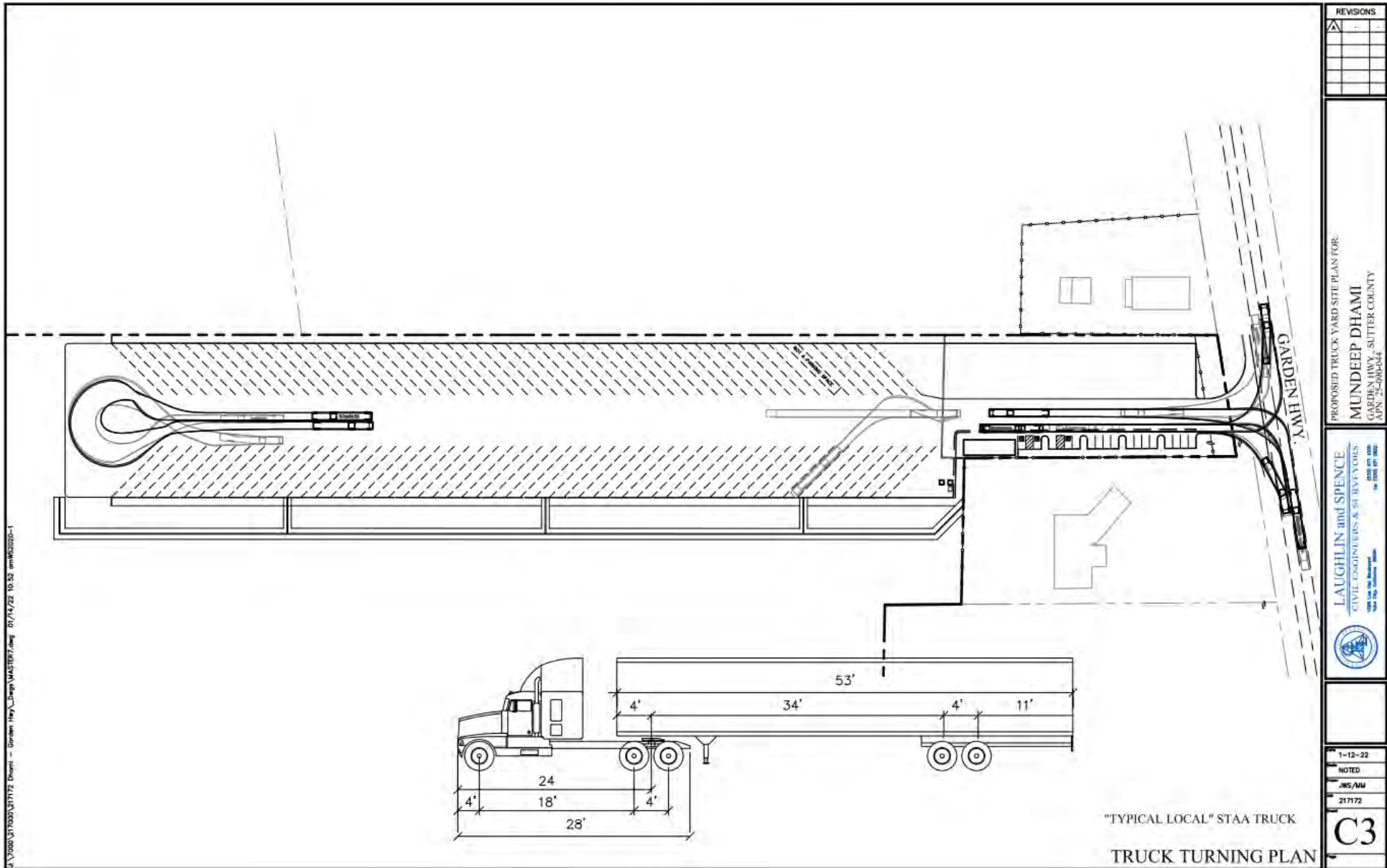

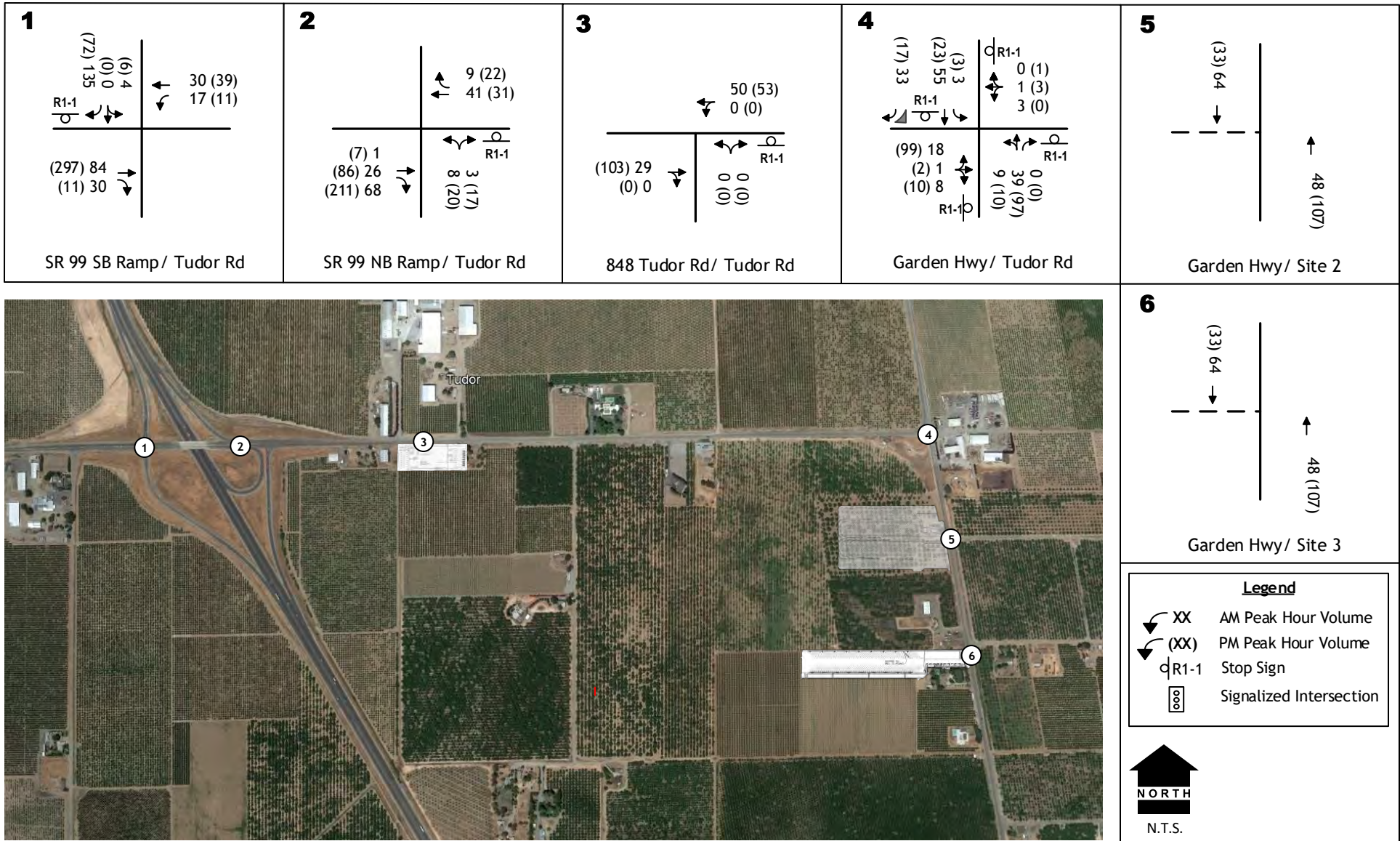

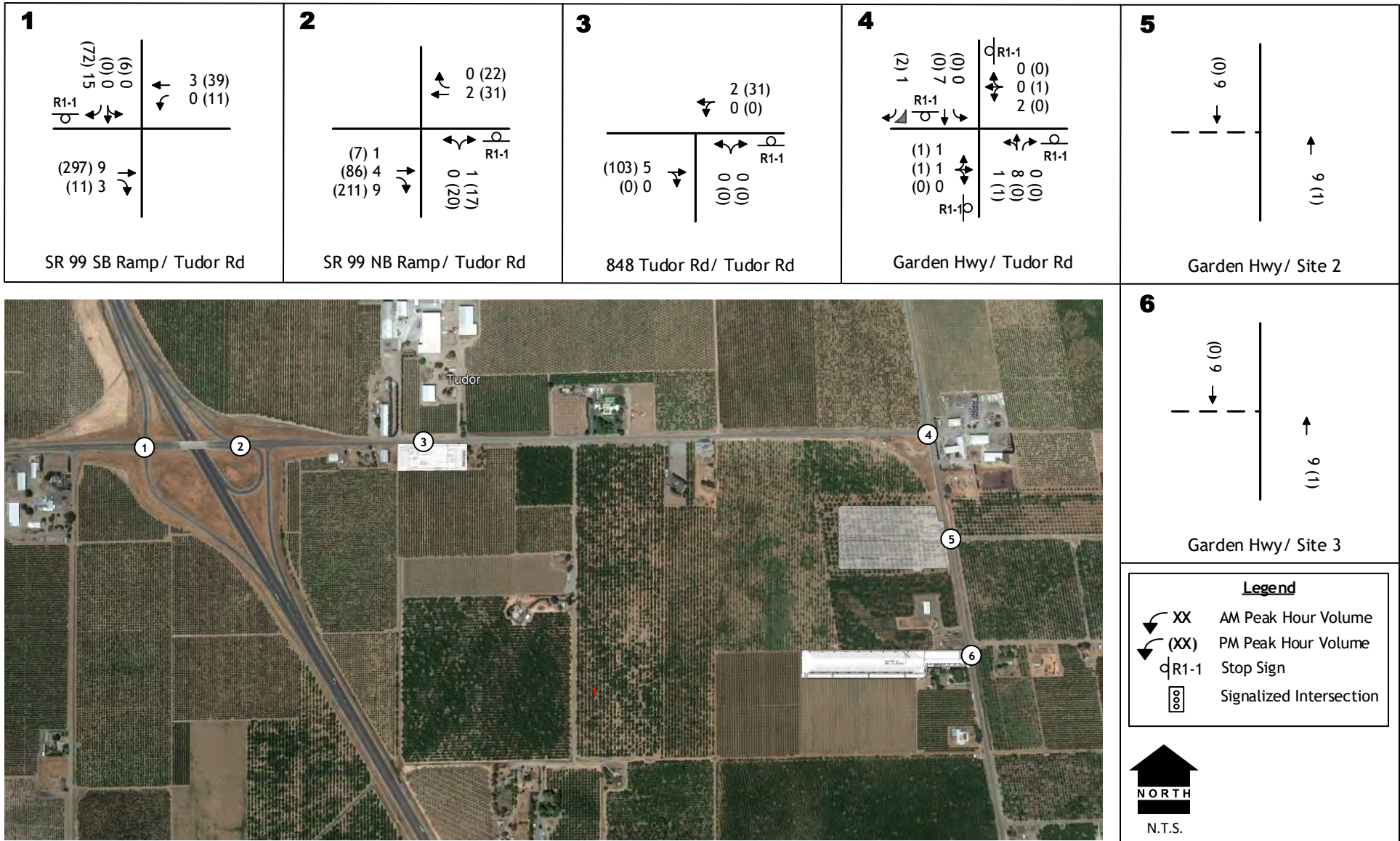

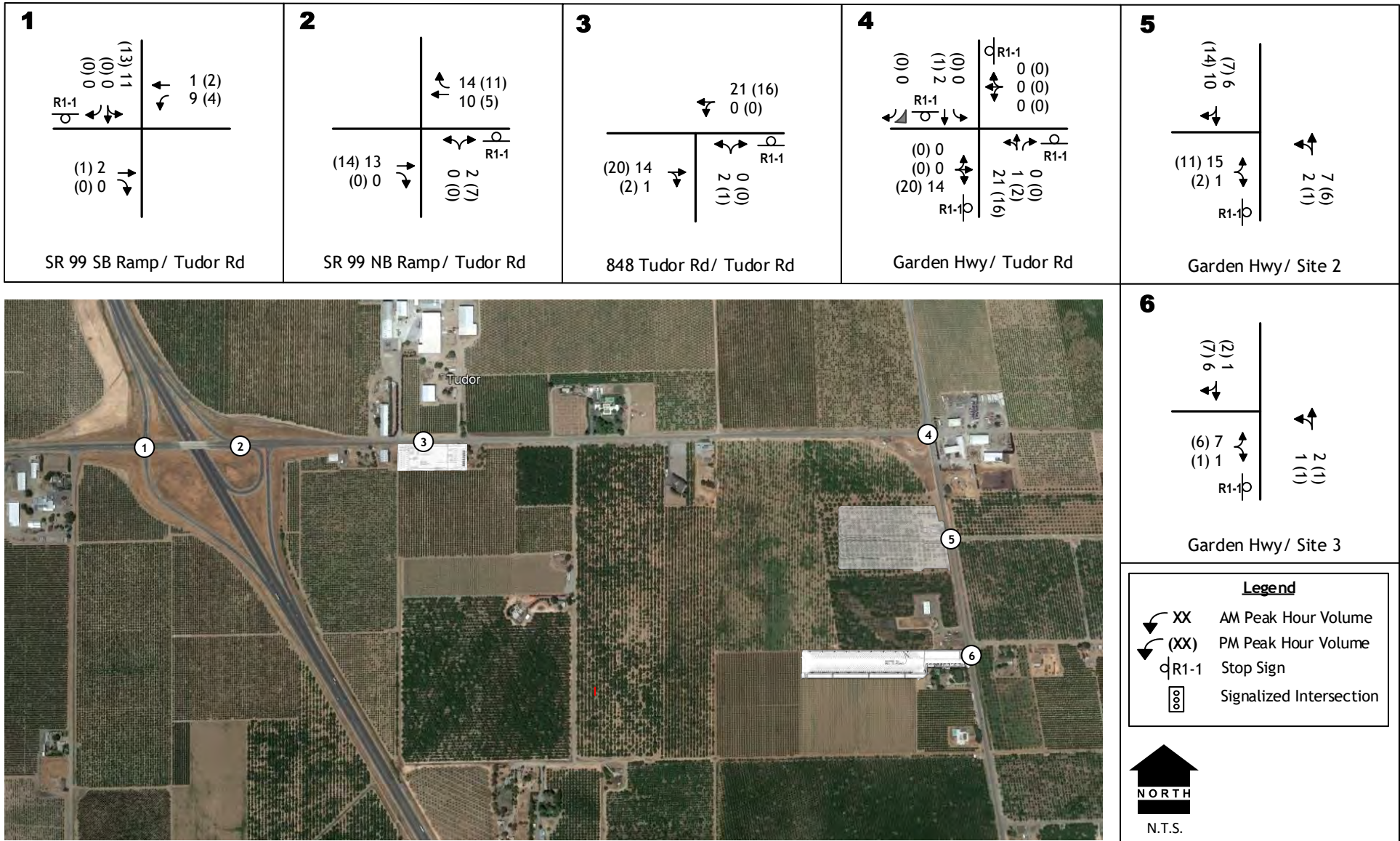

ALL THREE PROJECTS ALL VEHICLE TRAFFIC VOLUMES  
AND LANE CONFIGURATIONS

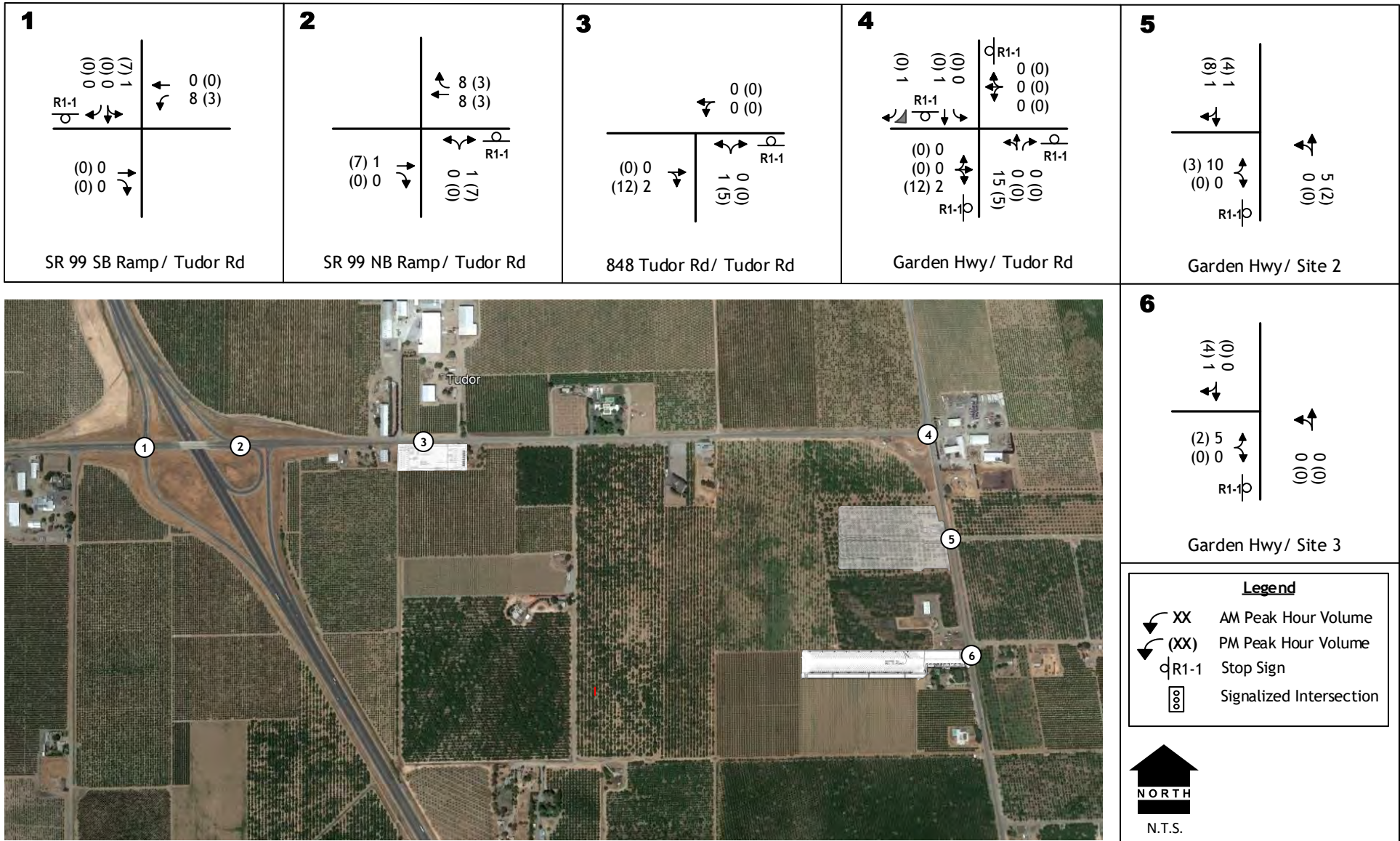

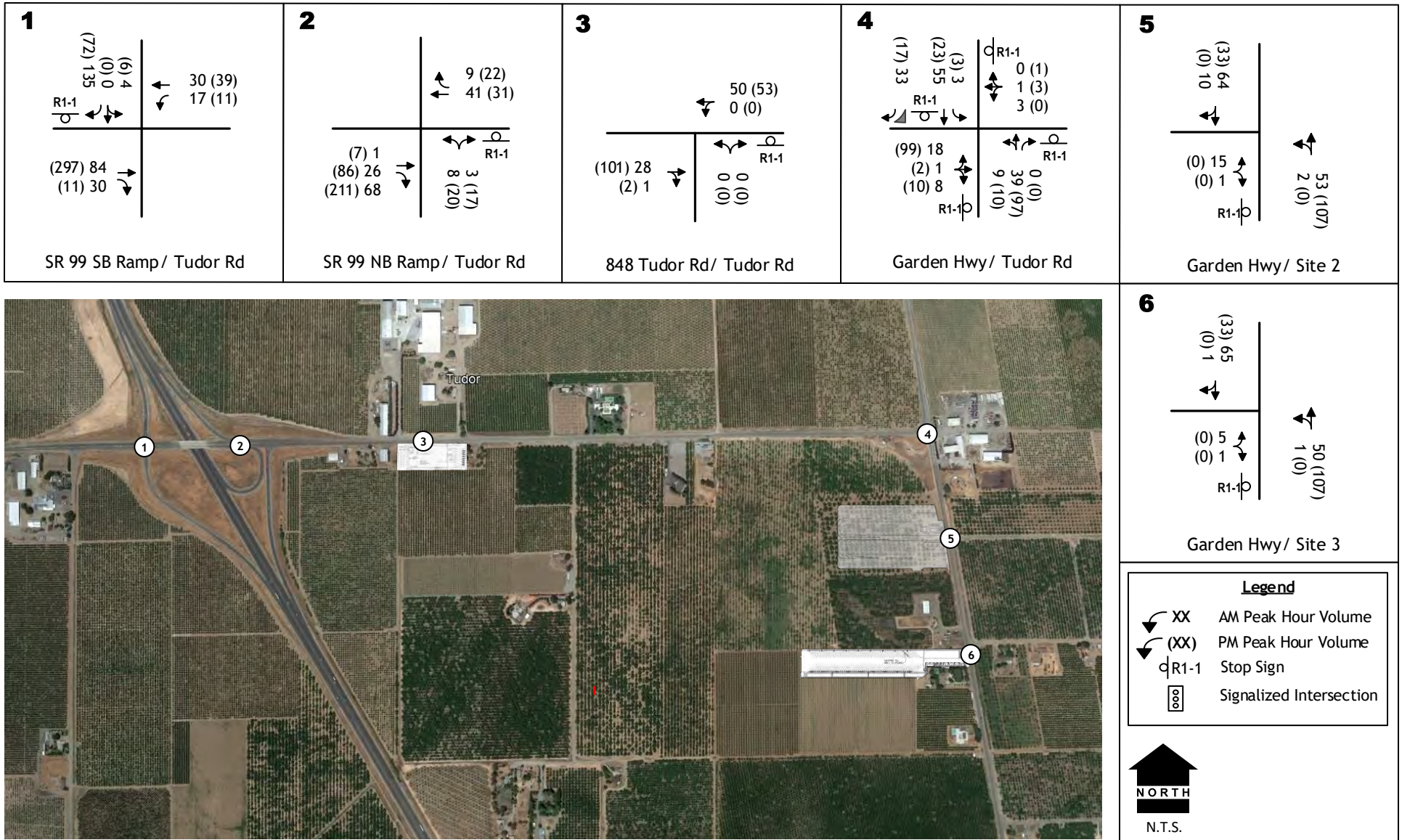

EXISTING PLUS ALL THREE PROJECTS ALL VEHICLE TRAFFIC VOLUMES  
AND LANE CONFIGURATIONS

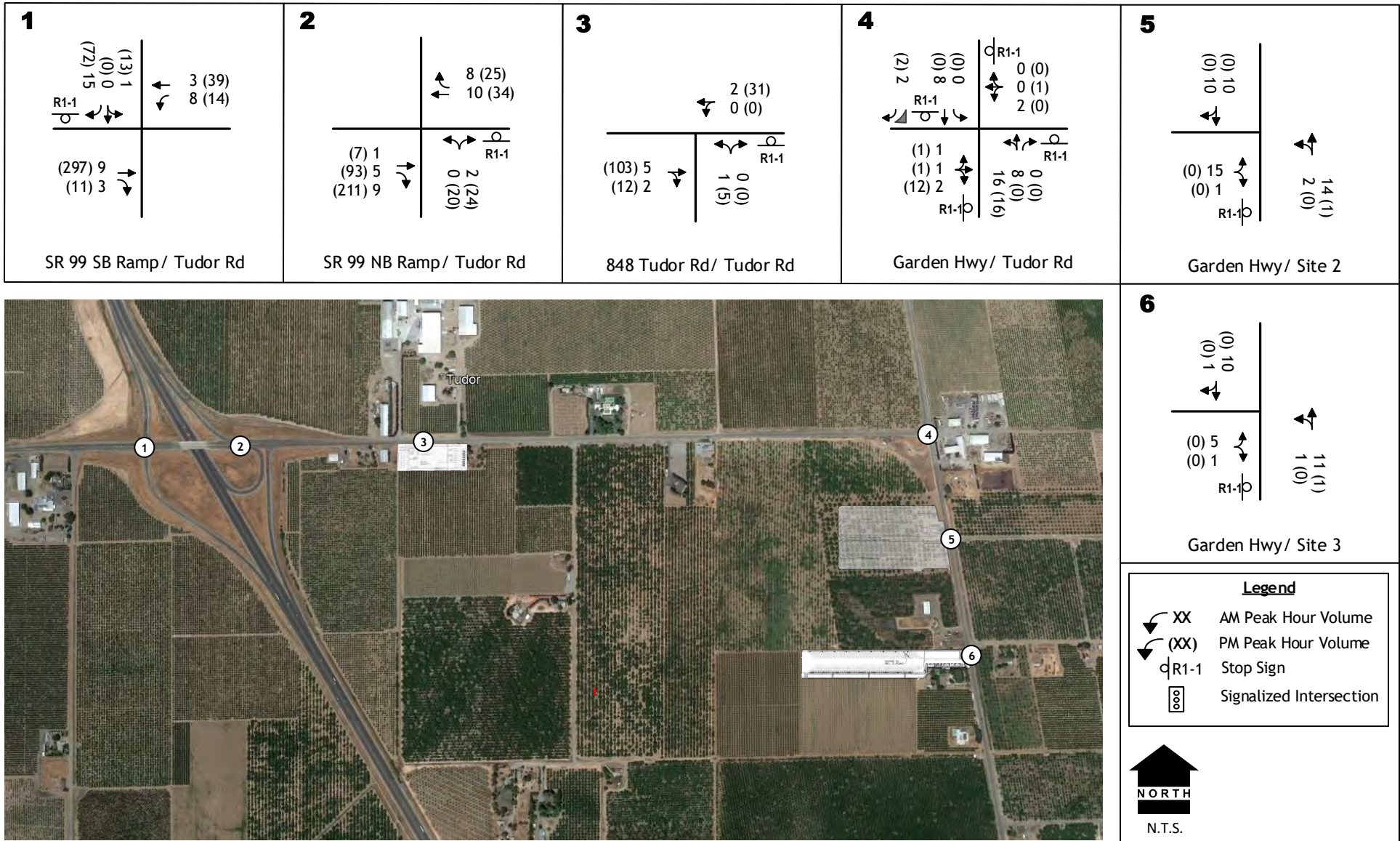

EXISTING PLUS ALL THREE PROJECTS TRUCK TRAFFIC VOLUMES AND LANE CONFIGURATIONS



<b>TABLE A 848 TUDOR ROAD TRUCK PARKING PROJECT TRIP GENERATION</b>											
Unit	Unit	Quantity	Trucks			Automobiles			Total		
			In	Out	Total	In	Out	Total	In	Out	Total
<i>AM Peak Hour</i>											
Long Haul	10 spaces	1	8%	92%	0.55	64%	36%	0.82	42%	58%	1.36
<b>Proposed</b>	<b>1.9 spaces</b>	<b>1.9</b>	<b>0</b>	<b>1</b>	<b>1</b>	<b>1</b>	<b>1</b>	<b>2</b>	<b>1</b>	<b>2</b>	<b>3</b>
<i>PM Peak Hour</i>											
Long Haul	10 spaces	1	71%	29%	0.55	43%	57%	0.82	54%	46%	1.36
<b>Proposed</b>	<b>1.9 spaces</b>	<b>1.9</b>	<b>1</b>	<b>0</b>	<b>1</b>	<b>1</b>	<b>1</b>	<b>2</b>	<b>2</b>	<b>1</b>	<b>3</b>
<i>Daily</i>											
Long Haul	10	1	50%	50%	7.64	50%	50%	11.45	50%	50%	19.10
<b>Proposed</b>	<b>1.9 spaces</b>	<b>2.1</b>	<b>8</b>	<b>7</b>	<b>15</b>	<b>11</b>	<b>11</b>	<b>22</b>	<b>19</b>	<b>18</b>	<b>37</b>

<b>TABLE B GARDEN HIGHWAY @ ASHCROFT ROAD TRUCK PARKING PROJECT TRIP GENERATION</b>											
Unit	Unit	Quantity	Trucks			Automobiles			Total		
			In	Out	Total	In	Out	Total	In	Out	Total
<i>AM Peak Hour</i>											
Long Haul	10 spaces	1	8%	92%	0.55	64%	36%	0.82	42%	58%	1.36
<b>Proposed</b>	<b>10.4 spaces</b>	<b>20.2</b>	<b>1</b>	<b>10</b>	<b>11</b>	<b>11</b>	<b>6</b>	<b>17</b>	<b>12</b>	<b>16</b>	<b>28</b>
<i>PM Peak Hour</i>											
Long Haul	10 spaces	1	71%	29%	0.55	43%	57%	0.82	54%	46%	1.36
<b>Proposed</b>	<b>20.2 spaces</b>	<b>20.2</b>	<b>8</b>	<b>3</b>	<b>11</b>	<b>7</b>	<b>10</b>	<b>17</b>	<b>15</b>	<b>13</b>	<b>28</b>
<i>Daily</i>											
Long Haul	10	1	50%	50%	7.64	50%	50%	11.45	50%	50%	19.10
<b>Proposed</b>	<b>20.2 spaces</b>	<b>20.2</b>	<b>77</b>	<b>77</b>	<b>154</b>	<b>115</b>	<b>116</b>	<b>231</b>	<b>192</b>	<b>193</b>	<b>385</b>

**TABLE C  
GARDEN HIGHWAY @ PECK ROAD TRUCK PARKING PROJECT TRIP GENERATION**

Unit	Unit	Quantity	Trucks			Automobiles			Total		
			In	Out	Total	In	Out	Total	In	Out	Total
<i>AM Peak Hour</i>											
Long Haul	10 spaces	1	8%	92%	0.55	64%	36%	0.82	42%	58%	1.36
<b>Proposed</b>	<b>10.4 spaces</b>	<b>10.4</b>	<b>1</b>	<b>5</b>	<b>6</b>	<b>6</b>	<b>3</b>	<b>9</b>	<b>7</b>	<b>8</b>	<b>15</b>
<i>PM Peak Hour</i>											
Long Haul	10 spaces	1	71%	29%	0.55	43%	57%	0.82	54%	46%	1.36
<b>Proposed</b>	<b>10.4 spaces</b>	<b>10.4</b>	<b>4</b>	<b>2</b>	<b>6</b>	<b>4</b>	<b>5</b>	<b>9</b>	<b>8</b>	<b>7</b>	<b>15</b>
<i>Daily</i>											
Long Haul	10	1	50%	50%	7.64	50%	50%	11.45	50%	50%	19.10
<b>Proposed</b>	<b>10.4 spaces</b>	<b>10.4</b>	<b>40</b>	<b>39</b>	<b>79</b>	<b>60</b>	<b>60</b>	<b>120</b>	<b>100</b>	<b>99</b>	<b>199</b>



# SR 99 NB Ramps & Tudor Rd

## Peak Hour Turning Movement Count

ID: 22-070040-002  
City: Yuba City

Day: Tuesday  
Date: 3/1/2022

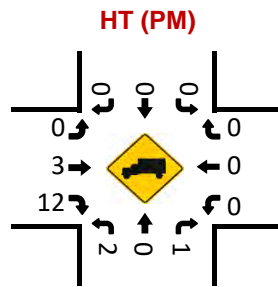
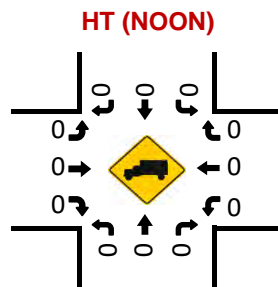
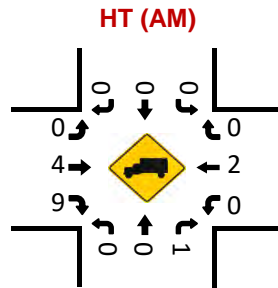
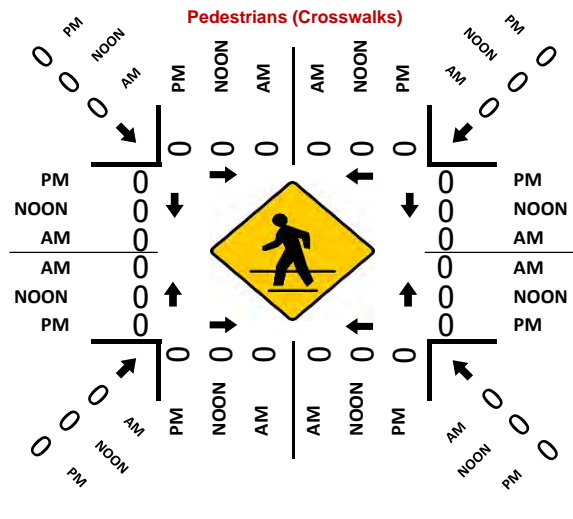
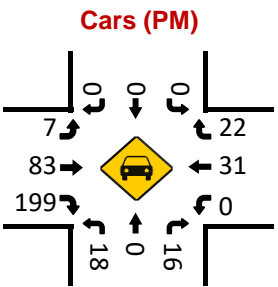
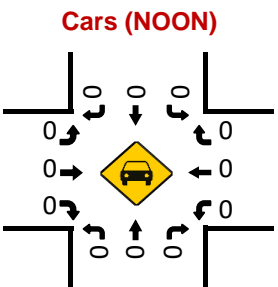
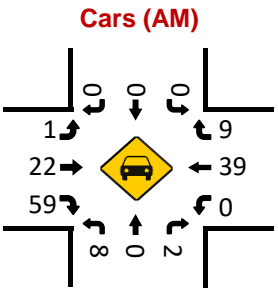
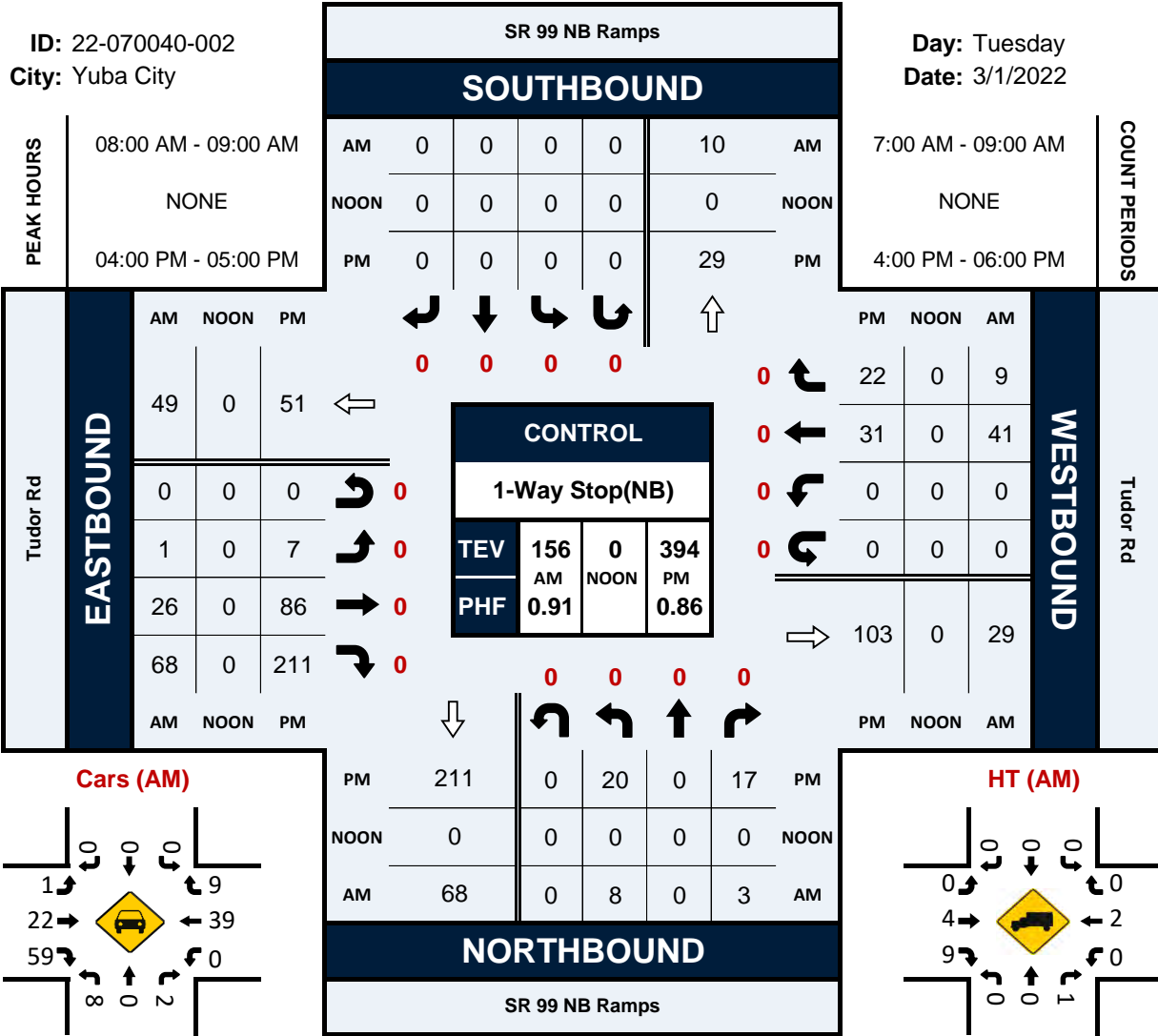

# National Data & Surveying Services Intersection Turning Movement Count

Location: SR 99 NB Ramps & Tudor Rd  
 City: Yuba City  
 Control: 1-Way Stop(NB)

Project ID: 22-070040-002  
 Date: 3/1/2022

## Data - Total

NS/EW Streets:	SR 99 NB Ramps				SR 99 NB Ramps				Tudor Rd				Tudor Rd				
AM	NORTHBOUND				SOUTHBOUND				EASTBOUND				WESTBOUND				
	NL	NT	NR	NU	SL	ST	SR	SU	EL	ET	ER	EU	WL	WT	WR	WU	TOTAL
7:00 AM	0	0	0	0	0	0	0	0	0	0	0	0	0	0	0	0	35
7:15 AM	3	0	0	0	0	0	0	0	0	4	17	0	0	12	3	0	39
7:30 AM	2	0	0	0	0	0	0	0	0	7	19	0	0	6	2	0	37
7:45 AM	3	0	0	0	0	0	0	0	0	8	16	0	0	7	2	0	35
8:00 AM	1	1	0	0	0	0	0	0	0	5	25	0	0	10	1	0	41
8:15 AM	0	0	0	0	0	0	0	0	0	7	13	0	0	10	4	0	35
8:30 AM	1	0	0	0	0	0	0	0	1	4	14	0	0	12	3	0	37
8:45 AM	3	0	0	0	0	0	0	0	0	10	16	0	0	9	1	0	43
8:45 AM	4	0	3	0	0	0	0	0	0	10	16	0	0	9	1	0	43
<b>TOTAL VOLUMES:</b>	NL	NT	NR	NU	SL	ST	SR	SU	EL	ET	ER	EU	WL	WT	WR	WU	TOTAL
<b>APPROACH %'s:</b>	17	1	3	0	0	0	0	0	1	51	131	0	0	79	19	0	302
	80.95%	4.76%	14.29%	0.00%					0.55%	27.87%	71.58%	0.00%	0.00%	80.61%	19.39%	0.00%	
<b>PEAK HR:</b>	08:00 AM - 09:00 AM																TOTAL
<b>PEAK HR VOL:</b>	8	0	3	0	0	0	0	0	1	26	68	0	0	41	9	0	156
<b>PEAK HR FACTOR:</b>	0.500	0.000	0.250	0.000	0.000	0.000	0.000	0.000	0.250	0.650	0.680	0.000	0.000	0.854	0.563	0.000	0.907
	0.393								0.792				0.833				
PM	NORTHBOUND				SOUTHBOUND				EASTBOUND				WESTBOUND				
	NL	NT	NR	NU	SL	ST	SR	SU	EL	ET	ER	EU	WL	WT	WR	WU	TOTAL
4:00 PM	0	0	0	0	0	0	0	0	0	31	61	0	0	8	8	0	114
4:15 PM	4	0	2	0	0	0	0	0	2	14	47	0	0	15	5	0	95
4:30 PM	5	0	7	0	0	0	0	0	3	23	61	0	0	4	5	0	108
4:45 PM	8	0	4	0	0	0	0	0	2	18	42	0	0	4	4	0	77
4:45 PM	3	0	4	0	0	0	0	0	2	18	42	0	0	4	4	0	77
5:00 PM	6	0	3	0	0	0	0	0	2	12	36	0	0	4	3	0	66
5:15 PM	4	0	4	0	0	0	0	0	2	18	33	0	0	8	2	0	71
5:30 PM	2	0	0	0	0	0	0	0	1	21	47	0	0	8	2	0	81
5:45 PM	5	0	1	0	0	0	0	0	1	15	31	0	0	3	3	0	59
5:45 PM	5	0	1	0	0	0	0	0	1	15	31	0	0	3	3	0	59
<b>TOTAL VOLUMES:</b>	NL	NT	NR	NU	SL	ST	SR	SU	EL	ET	ER	EU	WL	WT	WR	WU	TOTAL
<b>APPROACH %'s:</b>	37	0	25	0	0	0	0	0	13	152	358	0	0	54	32	0	671
	59.68%	0.00%	40.32%	0.00%					2.49%	29.06%	68.45%	0.00%	0.00%	62.79%	37.21%	0.00%	
<b>PEAK HR:</b>	04:00 PM - 05:00 PM																TOTAL
<b>PEAK HR VOL:</b>	20	0	17	0	0	0	0	0	7	86	211	0	0	31	22	0	394
<b>PEAK HR FACTOR:</b>	0.625	0.000	0.607	0.000	0.000	0.000	0.000	0.000	0.583	0.694	0.865	0.000	0.000	0.517	0.688	0.000	0.864
	0.771								0.826				0.663				

# National Data & Surveying Services Intersection Turning Movement Count

Location: SR 99 NB Ramps & Tudor Rd  
 City: Yuba City  
 Control: 1-Way Stop(NB)

Project ID: 22-070040-002  
 Date: 3/1/2022

## Data - Cars

NS/EW Streets:	SR 99 NB Ramps				SR 99 NB Ramps				Tudor Rd				Tudor Rd				
AM	NORTHBOUND				SOUTHBOUND				EASTBOUND				WESTBOUND				
	NL	NT	NR	NU	SL	ST	SR	SU	EL	ET	ER	EU	WL	WT	WR	WU	TOTAL
7:00 AM	0	0	0	0	0	0	0	0	0	0	0	0	0	0	0	0	31
7:15 AM	3	0	0	0	0	0	0	0	0	6	8	0	0	11	3	0	36
7:30 AM	2	0	0	0	0	0	0	0	0	4	15	0	0	12	3	0	33
7:45 AM	2	0	0	0	0	0	0	0	0	7	17	0	0	6	1	0	32
8:00 AM	1	1	0	0	0	0	0	0	0	8	14	0	0	7	1	0	37
8:15 AM	0	0	0	0	0	0	0	0	0	3	23	0	0	10	1	0	33
8:30 AM	1	0	0	0	0	0	0	0	0	5	13	0	0	10	4	0	30
8:45 AM	3	0	0	0	0	0	0	0	1	4	9	0	0	10	3	0	40
	4	0	2	0	0	0	0	0	0	10	14	0	0	9	1	0	
<b>TOTAL VOLUMES :</b>	NL	NT	NR	NU	SL	ST	SR	SU	EL	ET	ER	EU	WL	WT	WR	WU	TOTAL
<b>APPROACH %'s :</b>	16	1	2	0	0	0	0	0	1	47	113	0	0	75	17	0	272
	84.21%	5.26%	10.53%	0.00%					0.62%	29.19%	70.19%	0.00%	0.00%	81.52%	18.48%	0.00%	
<b>PEAK HR :</b>	08:00 AM - 09:00 AM																TOTAL
<b>PEAK HR VOL :</b>	8	0	2	0	0	0	0	0	1	22	59	0	0	39	9	0	140
<b>PEAK HR FACTOR :</b>	0.500	0.000	0.250	0.000	0.000	0.000	0.000	0.000	0.250	0.550	0.641	0.000	0.000	0.975	0.563	0.000	0.875
	0.417								0.788				0.857				
PM	NORTHBOUND				SOUTHBOUND				EASTBOUND				WESTBOUND				
	NL	NT	NR	NU	SL	ST	SR	SU	EL	ET	ER	EU	WL	WT	WR	WU	TOTAL
4:00 PM	4	0	2	0	0	0	0	0	0	30	59	0	0	8	8	0	111
4:15 PM	5	0	7	0	0	0	0	0	2	14	46	0	0	15	5	0	94
4:30 PM	8	0	4	0	0	0	0	0	3	22	56	0	0	4	5	0	102
4:45 PM	1	0	3	0	0	0	0	0	2	17	38	0	0	4	4	0	69
5:00 PM	6	0	3	0	0	0	0	0	2	12	33	0	0	2	3	0	61
5:15 PM	4	0	4	0	0	0	0	0	2	16	32	0	0	8	2	0	68
5:30 PM	2	0	0	0	0	0	0	0	1	21	43	0	0	8	1	0	76
5:45 PM	5	0	1	0	0	0	0	0	1	15	30	0	0	3	2	0	57
<b>TOTAL VOLUMES :</b>	NL	NT	NR	NU	SL	ST	SR	SU	EL	ET	ER	EU	WL	WT	WR	WU	TOTAL
<b>APPROACH %'s :</b>	35	0	24	0	0	0	0	0	13	147	337	0	0	52	30	0	638
	59.32%	0.00%	40.68%	0.00%					2.62%	29.58%	67.81%	0.00%	0.00%	63.41%	36.59%	0.00%	
<b>PEAK HR :</b>	04:00 PM - 05:00 PM																TOTAL
<b>PEAK HR VOL :</b>	18	0	16	0	0	0	0	0	7	83	199	0	0	31	22	0	376
<b>PEAK HR FACTOR :</b>	0.563	0.000	0.571	0.000	0.000	0.000	0.000	0.000	0.583	0.692	0.843	0.000	0.000	0.517	0.688	0.000	0.847
	0.708								0.812				0.663				

# National Data & Surveying Services Intersection Turning Movement Count

Location: SR 99 NB Ramps & Tudor Rd  
 City: Yuba City  
 Control: 1-Way Stop(NB)

Project ID: 22-070040-002  
 Date: 3/1/2022

## Data - HT

NS/EW Streets:	SR 99 NB Ramps				SR 99 NB Ramps				Tudor Rd				Tudor Rd				
AM	NORTHBOUND				SOUTHBOUND				EASTBOUND				WESTBOUND				
	NL	NT	NR	NU	SL	ST	SR	SU	EL	ET	ER	EU	WL	WT	WR	WU	TOTAL
7:00 AM	0	0	0	0	0	0	0	0	0	0	3	0	0	1	0	0	4
7:15 AM	0	0	0	0	0	0	0	0	0	0	2	0	0	1	0	0	3
7:30 AM	1	0	0	0	0	0	0	0	0	0	2	0	0	0	1	0	4
7:45 AM	0	0	0	0	0	0	0	0	0	0	2	0	0	0	1	0	3
8:00 AM	0	0	0	0	0	0	0	0	0	2	2	0	0	0	0	0	4
8:15 AM	0	0	0	0	0	0	0	0	0	2	0	0	0	0	0	0	2
8:30 AM	0	0	0	0	0	0	0	0	0	0	5	0	0	2	0	0	7
8:45 AM	0	0	1	0	0	0	0	0	0	0	2	0	0	0	0	0	3
<b>TOTAL VOLUMES :</b>	NL	NT	NR	NU	SL	ST	SR	SU	EL	ET	ER	EU	WL	WT	WR	WU	TOTAL
<b>APPROACH %'s :</b>	50.00%	0.00%	50.00%	0.00%	0	0	0	0	0.00%	18.18%	81.82%	0.00%	0.00%	66.67%	33.33%	0.00%	30
<b>PEAK HR :</b>	08:00 AM - 09:00 AM																TOTAL
<b>PEAK HR VOL :</b>	0	0	1	0	0	0	0	0	0	4	9	0	0	2	0	0	16
<b>PEAK HR FACTOR :</b>	0.000	0.000	0.250	0.000	0.000	0.000	0.000	0.000	0.000	0.500	0.450	0.000	0.000	0.250	0.000	0.000	0.571
	0.250								0.650				0.250				
PM	NORTHBOUND				SOUTHBOUND				EASTBOUND				WESTBOUND				
	NL	NT	NR	NU	SL	ST	SR	SU	EL	ET	ER	EU	WL	WT	WR	WU	TOTAL
4:00 PM	0	0	0	0	0	0	0	0	0	1	2	0	0	0	0	0	3
4:15 PM	0	0	0	0	0	0	0	0	0	0	1	0	0	0	0	0	1
4:30 PM	0	0	0	0	0	0	0	0	0	1	5	0	0	0	0	0	6
4:45 PM	2	0	1	0	0	0	0	0	0	1	4	0	0	0	0	0	8
5:00 PM	0	0	0	0	0	0	0	0	0	0	3	0	0	2	0	0	5
5:15 PM	0	0	0	0	0	0	0	0	0	2	1	0	0	0	0	0	3
5:30 PM	0	0	0	0	0	0	0	0	0	0	4	0	0	0	1	0	5
5:45 PM	0	0	0	0	0	0	0	0	0	0	1	0	0	0	1	0	2
<b>TOTAL VOLUMES :</b>	NL	NT	NR	NU	SL	ST	SR	SU	EL	ET	ER	EU	WL	WT	WR	WU	TOTAL
<b>APPROACH %'s :</b>	66.67%	0.00%	33.33%	0.00%	0	0	0	0	0.00%	19.23%	80.77%	0.00%	0.00%	50.00%	50.00%	0.00%	33
<b>PEAK HR :</b>	04:00 PM - 05:00 PM																TOTAL
<b>PEAK HR VOL :</b>	2	0	1	0	0	0	0	0	0	3	12	0	0	0	0	0	18
<b>PEAK HR FACTOR :</b>	0.250	0.000	0.250	0.000	0.000	0.000	0.000	0.000	0.000	0.750	0.600	0.000	0.000	0.000	0.000	0.000	0.563
	0.250								0.625								

# National Data & Surveying Services Intersection Turning Movement Count

Location: SR 99 NB Ramps & Tudor Rd  
 City: Yuba City  
 Control: 1-Way Stop(NB)

Project ID: 22-070040-002  
 Date: 3/1/2022

## Data - Bikes

NS/EW Streets:	SR 99 NB Ramps				SR 99 NB Ramps				Tudor Rd				Tudor Rd				
AM	NORTHBOUND				SOUTHBOUND				EASTBOUND				WESTBOUND				
	NL	NT	NR	NU	SL	ST	SR	SU	EL	ET	ER	EU	WL	WT	WR	WU	TOTAL
7:00 AM	0	0	0	0	0	0	0	0	0	0	0	0	0	0	0	0	0
7:15 AM	0	0	0	0	0	0	0	0	0	0	0	0	0	0	0	0	0
7:30 AM	0	0	0	0	0	0	0	0	0	0	0	0	0	0	0	0	0
7:45 AM	0	0	0	0	0	0	0	0	0	0	0	0	0	0	0	0	0
8:00 AM	0	0	0	0	0	0	0	0	0	0	0	0	0	0	0	0	0
8:15 AM	0	0	0	0	0	0	0	0	0	0	0	0	0	0	0	0	0
8:30 AM	0	0	0	0	0	0	0	0	0	0	0	0	0	0	0	0	0
8:45 AM	0	0	0	0	0	0	0	0	0	0	0	0	0	0	0	0	0
<b>TOTAL VOLUMES :</b>	NL	NT	NR	NU	SL	ST	SR	SU	EL	ET	ER	EU	WL	WT	WR	WU	TOTAL
<b>APPROACH %'s :</b>	0	0	0	0	0	0	0	0	0	0	0	0	0	0	0	0	0
<b>PEAK HR :</b>	08:00 AM - 09:00 AM																TOTAL
<b>PEAK HR VOL :</b>	0	0	0	0	0	0	0	0	0	0	0	0	0	0	0	0	0
<b>PEAK HR FACTOR :</b>	0.000	0.000	0.000	0.000	0.000	0.000	0.000	0.000	0.000	0.000	0.000	0.000	0.000	0.000	0.000	0.000	0
PM	NORTHBOUND				SOUTHBOUND				EASTBOUND				WESTBOUND				
	NL	NT	NR	NU	SL	ST	SR	SU	EL	ET	ER	EU	WL	WT	WR	WU	TOTAL
4:00 PM	0	0	0	0	0	0	0	0	0	0	0	0	0	0	0	0	0
4:15 PM	0	0	0	0	0	0	0	0	0	0	0	0	0	0	0	0	0
4:30 PM	0	0	0	0	0	0	0	0	0	0	0	0	0	0	0	0	0
4:45 PM	0	0	0	0	0	0	0	0	0	0	0	0	0	1	0	0	1
5:00 PM	0	0	0	0	0	0	0	0	0	0	0	0	0	0	0	0	0
5:15 PM	0	0	0	0	0	0	0	0	0	0	0	0	0	0	0	0	0
5:30 PM	0	0	0	0	0	0	0	0	0	0	0	0	0	0	0	0	0
5:45 PM	0	0	0	0	0	0	0	0	0	0	0	0	0	0	0	0	0
<b>TOTAL VOLUMES :</b>	NL	NT	NR	NU	SL	ST	SR	SU	EL	ET	ER	EU	WL	WT	WR	WU	TOTAL
<b>APPROACH %'s :</b>	0	0	0	0	0	0	0	0	0	0	0	0	0.00%	100.00%	0.00%	0.00%	1
<b>PEAK HR :</b>	04:00 PM - 05:00 PM																TOTAL
<b>PEAK HR VOL :</b>	0	0	0	0	0	0	0	0	0	0	0	0	0	1	0	0	1
<b>PEAK HR FACTOR :</b>	0.000	0.000	0.000	0.000	0.000	0.000	0.000	0.000	0.000	0.000	0.000	0.000	0.000	0.250	0.000	0.000	0.250



# SR 99 SB Ramps & Tudor Rd/SR 113

## Peak Hour Turning Movement Count

ID: 22-070040-003  
City: Yuba City

Day: Tuesday  
Date: 3/1/2022

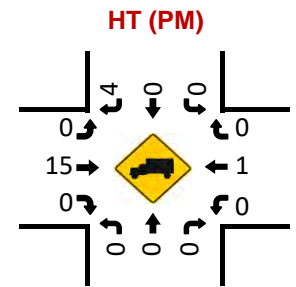
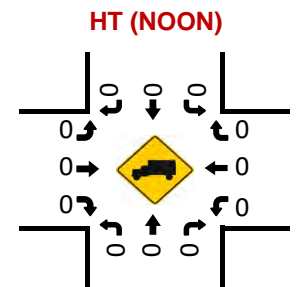
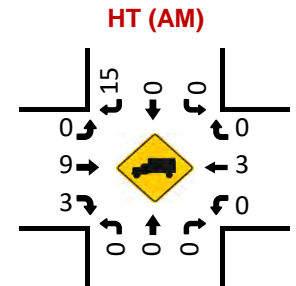
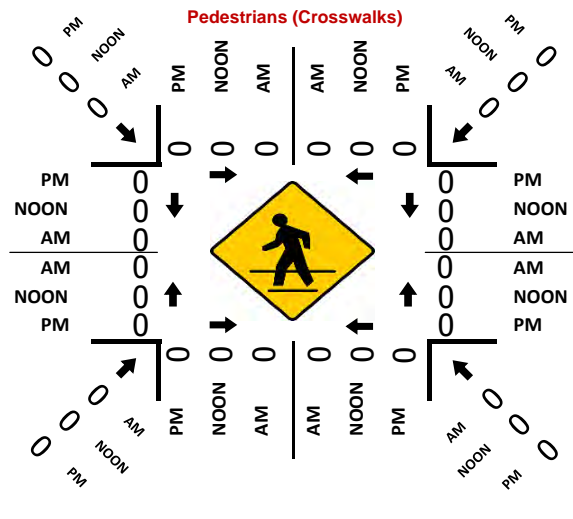
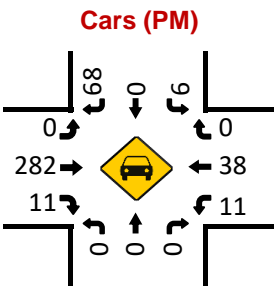
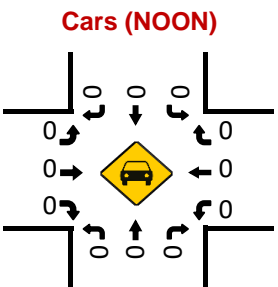
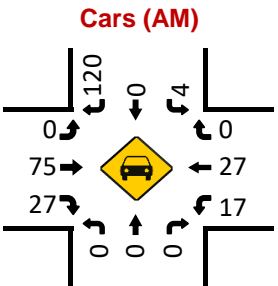
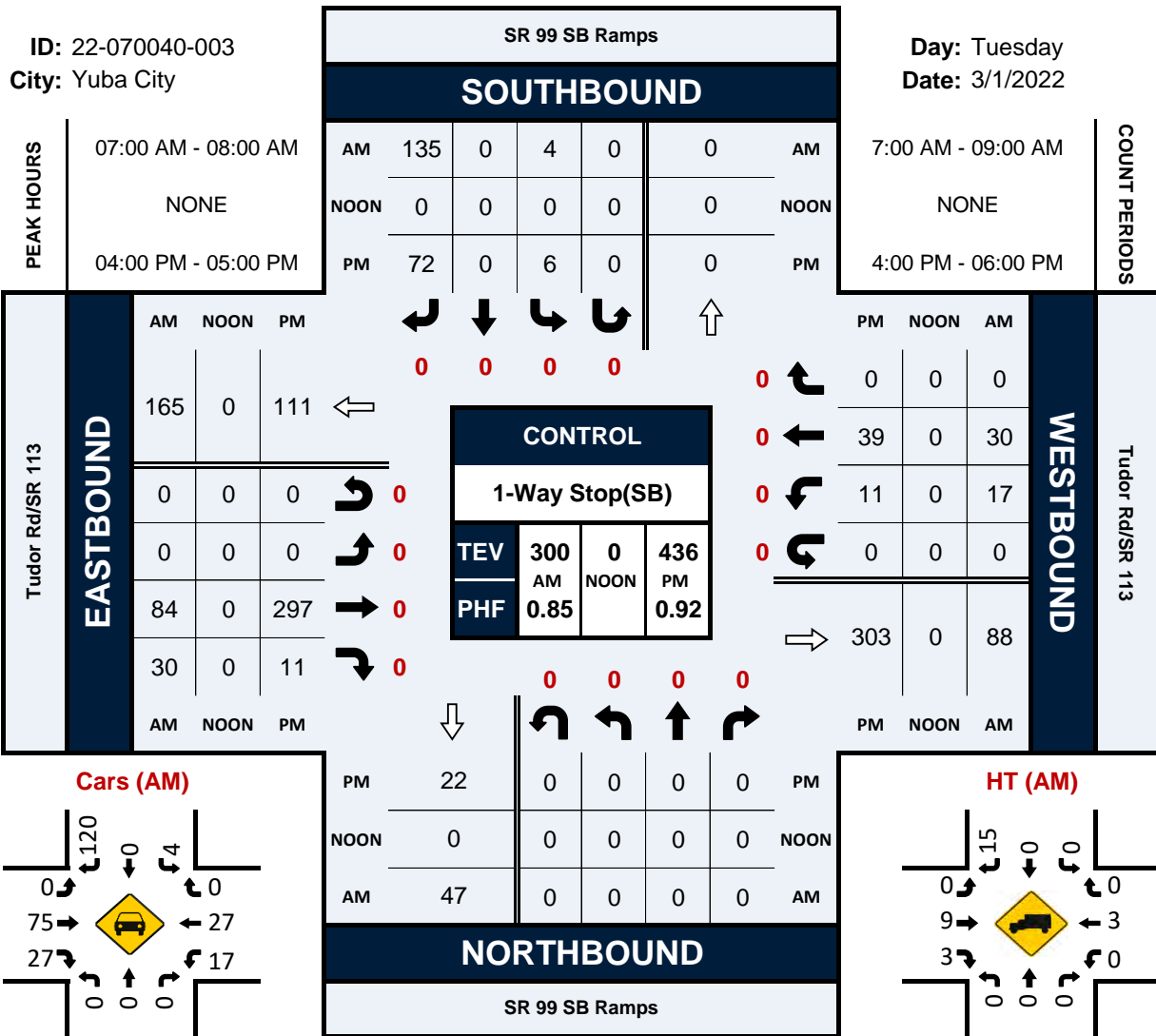

# National Data & Surveying Services Intersection Turning Movement Count

Location: SR 99 SB Ramps & Tudor Rd/SR 113  
 City: Yuba City  
 Control: 1-Way Stop(SB)

Project ID: 22-070040-003  
 Date: 3/1/2022

## Data - Total

NS/EW Streets:	SR 99 SB Ramps				SR 99 SB Ramps				Tudor Rd/SR 113				Tudor Rd/SR 113				
AM	NORTHBOUND				SOUTHBOUND				EASTBOUND				WESTBOUND				
	0 NL	0 NT	0 NR	0 NU	0 SL	0 ST	0 SR	0 SU	0 EL	0 ET	0 ER	0 EU	0 WL	0 WT	0 WR	0 WU	TOTAL
7:00 AM	0	0	0	0	1	0	45	0	0	16	10	0	7	9	0	0	88
7:15 AM	0	0	0	0	0	0	31	0	0	22	8	0	5	9	0	0	75
7:30 AM	0	0	0	0	1	0	35	0	0	24	5	0	3	7	0	0	75
7:45 AM	0	0	0	0	2	0	24	0	0	22	7	0	2	5	0	0	62
8:00 AM	0	0	0	0	1	0	27	0	0	29	6	0	3	8	0	0	74
8:15 AM	0	0	0	0	2	0	25	0	0	18	3	0	5	6	0	0	59
8:30 AM	0	0	0	0	2	0	26	0	0	18	6	0	6	8	0	0	66
8:45 AM	0	0	0	0	4	0	22	0	0	21	7	0	6	8	0	0	68
<b>TOTAL VOLUMES:</b>	NL	NT	NR	NU	SL	ST	SR	SU	EL	ET	ER	EU	WL	WT	WR	WU	TOTAL
<b>APPROACH %'s:</b>	0	0	0	0	13	0	235	0	0	170	52	0	37	60	0	0	567
					5.24%	0.00%	94.76%	0.00%	0.00%	76.58%	23.42%	0.00%	38.14%	61.86%	0.00%	0.00%	
<b>PEAK HR:</b>	07:00 AM - 08:00 AM																TOTAL
<b>PEAK HR VOL:</b>	0	0	0	0	4	0	135	0	0	84	30	0	17	30	0	0	300
<b>PEAK HR FACTOR:</b>	0.000	0.000	0.000	0.000	0.500	0.000	0.750	0.000	0.000	0.875	0.750	0.000	0.607	0.833	0.000	0.000	0.852
							0.755				0.950				0.734		
PM	NORTHBOUND				SOUTHBOUND				EASTBOUND				WESTBOUND				
	0 NL	0 NT	0 NR	0 NU	0 SL	0 ST	0 SR	0 SU	0 EL	0 ET	0 ER	0 EU	0 WL	0 WT	0 WR	0 WU	TOTAL
4:00 PM	0	0	0	0	4	0	14	0	0	84	4	0	3	9	0	0	118
4:15 PM	0	0	0	0	0	0	21	0	0	67	2	0	4	15	0	0	109
4:30 PM	0	0	0	0	1	0	19	0	0	83	3	0	2	11	0	0	119
4:45 PM	0	0	0	0	1	0	18	0	0	63	2	0	2	4	0	0	90
5:00 PM	0	0	0	0	3	0	17	0	0	45	3	0	2	9	0	0	79
5:15 PM	0	0	0	0	3	0	19	0	0	54	9	0	2	10	0	0	97
5:30 PM	0	0	0	0	3	0	16	0	0	61	1	0	3	7	0	0	91
5:45 PM	0	0	0	0	2	1	15	0	0	45	0	0	3	5	0	0	71
<b>TOTAL VOLUMES:</b>	NL	NT	NR	NU	SL	ST	SR	SU	EL	ET	ER	EU	WL	WT	WR	WU	TOTAL
<b>APPROACH %'s:</b>	0	0	0	0	17	1	139	0	0	502	24	0	21	70	0	0	774
					10.83%	0.64%	88.54%	0.00%	0.00%	95.44%	4.56%	0.00%	23.08%	76.92%	0.00%	0.00%	
<b>PEAK HR:</b>	04:00 PM - 05:00 PM																TOTAL
<b>PEAK HR VOL:</b>	0	0	0	0	6	0	72	0	0	297	11	0	11	39	0	0	436
<b>PEAK HR FACTOR:</b>	0.000	0.000	0.000	0.000	0.375	0.000	0.857	0.000	0.000	0.884	0.688	0.000	0.688	0.650	0.000	0.000	0.916
							0.929				0.875				0.658		

# National Data & Surveying Services Intersection Turning Movement Count

**Location:** SR 99 SB Ramps & Tudor Rd/SR 113  
**City:** Yuba City  
**Control:** 1-Way Stop(SB)

**Project ID:** 22-070040-003  
**Date:** 3/1/2022

## Data - Cars

NS/EW Streets:	SR 99 SB Ramps				SR 99 SB Ramps				Tudor Rd/SR 113				Tudor Rd/SR 113							
AM	NORTHBOUND				SOUTHBOUND				EASTBOUND				WESTBOUND							
	0	0	0	0	0	0	0	0	0	0	0	0	0	0	0	0	0	0	0	0
	NL	NT	NR	NU	SL	ST	SR	SU	EL	ET	ER	EU	WL	WT	WR	WU	TOTAL			
7:00 AM	0	0	0	0	1	0	39	0	0	13	9	0	7	8	0	0	77			
7:15 AM	0	0	0	0	0	0	30	0	0	20	8	0	5	8	0	0	71			
7:30 AM	0	0	0	0	1	0	31	0	0	22	4	0	3	6	0	0	67			
7:45 AM	0	0	0	0	2	0	20	0	0	20	6	0	2	5	0	0	55			
8:00 AM	0	0	0	0	0	0	24	0	0	26	6	0	3	8	0	0	67			
8:15 AM	0	0	0	0	1	0	22	0	0	17	3	0	5	6	0	0	54			
8:30 AM	0	0	0	0	2	0	25	0	0	13	4	0	6	7	0	0	57			
8:45 AM	0	0	0	0	4	0	16	0	0	19	5	0	6	7	0	0	57			
<b>TOTAL VOLUMES:</b>	NL	NT	NR	NU	SL	ST	SR	SU	EL	ET	ER	EU	WL	WT	WR	WU	TOTAL			
<b>APPROACH %'s:</b>	0	0	0	0	11	0	207	0	0	150	45	0	37	55	0	0	505			
					5.05%	0.00%	94.95%	0.00%	0.00%	76.92%	23.08%	0.00%	40.22%	59.78%	0.00%	0.00%				
<b>PEAK HR:</b>	07:00 AM - 08:00 AM																TOTAL			
<b>PEAK HR VOL:</b>	0	0	0	0	4	0	120	0	0	75	27	0	17	27	0	0	270			
<b>PEAK HR FACTOR:</b>	0.000	0.000	0.000	0.000	0.500	0.000	0.769	0.000	0.000	0.852	0.750	0.000	0.607	0.844	0.000	0.000	0.877			
					0.775				0.911				0.733							
PM	NORTHBOUND				SOUTHBOUND				EASTBOUND				WESTBOUND							
	0	0	0	0	0	0	0	0	0	0	0	0	0	0	0	0	0	0	0	0
	NL	NT	NR	NU	SL	ST	SR	SU	EL	ET	ER	EU	WL	WT	WR	WU	TOTAL			
4:00 PM	0	0	0	0	4	0	12	0	0	81	4	0	3	9	0	0	113			
4:15 PM	0	0	0	0	0	0	20	0	0	66	2	0	4	15	0	0	107			
4:30 PM	0	0	0	0	1	0	19	0	0	76	3	0	2	11	0	0	112			
4:45 PM	0	0	0	0	1	0	17	0	0	59	2	0	2	3	0	0	84			
5:00 PM	0	0	0	0	3	0	16	0	0	42	3	0	1	7	0	0	72			
5:15 PM	0	0	0	0	3	0	17	0	0	51	9	0	2	10	0	0	92			
5:30 PM	0	0	0	0	2	0	14	0	0	58	1	0	3	7	0	0	85			
5:45 PM	0	0	0	0	2	1	14	0	0	44	0	0	3	5	0	0	69			
<b>TOTAL VOLUMES:</b>	NL	NT	NR	NU	SL	ST	SR	SU	EL	ET	ER	EU	WL	WT	WR	WU	TOTAL			
<b>APPROACH %'s:</b>	0	0	0	0	16	1	129	0	0	477	24	0	20	67	0	0	734			
					10.96%	0.68%	88.36%	0.00%	0.00%	95.21%	4.79%	0.00%	22.99%	77.01%	0.00%	0.00%				
<b>PEAK HR:</b>	04:00 PM - 05:00 PM																TOTAL			
<b>PEAK HR VOL:</b>	0	0	0	0	6	0	68	0	0	282	11	0	11	38	0	0	416			
<b>PEAK HR FACTOR:</b>	0.000	0.000	0.000	0.000	0.375	0.000	0.850	0.000	0.000	0.870	0.688	0.000	0.688	0.633	0.000	0.000	0.920			
					0.925				0.862				0.645							

# National Data & Surveying Services Intersection Turning Movement Count

Location: SR 99 SB Ramps & Tudor Rd/SR 113  
 City: Yuba City  
 Control: 1-Way Stop(SB)

Project ID: 22-070040-003  
 Date: 3/1/2022

## Data - HT

NS/EW Streets:	SR 99 SB Ramps				SR 99 SB Ramps				Tudor Rd/SR 113				Tudor Rd/SR 113									
AM	NORTHBOUND				SOUTHBOUND				EASTBOUND				WESTBOUND									
		0	0	0	0		0	0	0		0	0	0		0	0	0	TOTAL				
		NL	NT	NR	NU		SL	ST	SR	SU		EL	ET	ER	EU		WL	WT	WR	WU		
	7:00 AM	0	0	0	0	0	0	6	0	0	3	1	0	0	1	0	0	0	0	0	0	11
	7:15 AM	0	0	0	0	0	0	1	0	0	2	0	0	0	1	0	0	0	0	0	0	4
	7:30 AM	0	0	0	0	0	0	4	0	0	2	1	0	0	1	0	0	0	0	0	0	8
	7:45 AM	0	0	0	0	0	0	4	0	0	2	1	0	0	0	0	0	0	0	0	0	7
	8:00 AM	0	0	0	0	1	0	3	0	0	3	0	0	0	0	0	0	0	0	0	0	7
	8:15 AM	0	0	0	0	1	0	3	0	0	1	0	0	0	0	0	0	0	0	0	0	5
	8:30 AM	0	0	0	0	0	0	1	0	0	5	2	0	0	1	0	0	0	0	0	0	9
8:45 AM	0	0	0	0	0	0	6	0	0	2	2	0	0	1	0	0	0	0	0	0	11	
<b>TOTAL VOLUMES:</b>	NL	NT	NR	NU	SL	ST	SR	SU	EL	ET	ER	EU	WL	WT	WR	WU	TOTAL					
<b>APPROACH %'s:</b>	0	0	0	0	2	0	28	0	0	20	7	0	0	5	0	0	62					
					6.67%	0.00%	93.33%	0.00%	0.00%	74.07%	25.93%	0.00%	0.00%	100.00%	0.00%	0.00%						
<b>PEAK HR:</b>	07:00 AM - 08:00 AM																TOTAL					
<b>PEAK HR VOL:</b>	0	0	0	0	0	0	15	0	0	9	3	0	0	3	0	0	30					
<b>PEAK HR FACTOR:</b>	0.000	0.000	0.000	0.000	0.000	0.000	0.625	0.000	0.000	0.750	0.750	0.000	0.000	0.750	0.000	0.000	0.682					
							0.625				0.750				0.750							
PM	NORTHBOUND				SOUTHBOUND				EASTBOUND				WESTBOUND									
		0	0	0	0		0	0	0		0	0	0		0	0	0	TOTAL				
		NL	NT	NR	NU		SL	ST	SR	SU		EL	ET	ER	EU		WL	WT	WR	WU		
	4:00 PM	0	0	0	0	0	0	2	0	0	3	0	0	0	0	0	0	5				
	4:15 PM	0	0	0	0	0	0	1	0	0	1	0	0	0	0	0	0	2				
	4:30 PM	0	0	0	0	0	0	0	0	0	7	0	0	0	0	0	0	7				
	4:45 PM	0	0	0	0	0	0	1	0	0	4	0	0	0	1	0	0	6				
	5:00 PM	0	0	0	0	0	0	1	0	0	3	0	0	1	2	0	0	7				
	5:15 PM	0	0	0	0	0	0	2	0	0	3	0	0	0	0	0	0	5				
	5:30 PM	0	0	0	0	1	0	2	0	0	3	0	0	0	0	0	0	6				
5:45 PM	0	0	0	0	0	0	1	0	0	1	0	0	0	0	0	0	2					
<b>TOTAL VOLUMES:</b>	NL	NT	NR	NU	SL	ST	SR	SU	EL	ET	ER	EU	WL	WT	WR	WU	TOTAL					
<b>APPROACH %'s:</b>	0	0	0	0	1	0	10	0	0	25	0	0	1	3	0	0	40					
					9.09%	0.00%	90.91%	0.00%	0.00%	100.00%	0.00%	0.00%	25.00%	75.00%	0.00%	0.00%						
<b>PEAK HR:</b>	04:00 PM - 05:00 PM																TOTAL					
<b>PEAK HR VOL:</b>	0	0	0	0	0	0	4	0	0	15	0	0	0	1	0	0	20					
<b>PEAK HR FACTOR:</b>	0.000	0.000	0.000	0.000	0.000	0.000	0.500	0.000	0.000	0.536	0.000	0.000	0.000	0.250	0.000	0.000	0.714					
							0.500				0.536				0.250							

# National Data & Surveying Services Intersection Turning Movement Count

Location: SR 99 SB Ramps & Tudor Rd/SR 113  
 City: Yuba City  
 Control: 1-Way Stop(SB)

Project ID: 22-070040-003  
 Date: 3/1/2022

## Data - Bikes

NS/EW Streets:	SR 99 SB Ramps				SR 99 SB Ramps				Tudor Rd/SR 113				Tudor Rd/SR 113				
<b>AM</b>	NORTHBOUND				SOUTHBOUND				EASTBOUND				WESTBOUND				TOTAL
	0	0	0	0	0	0	0	0	0	0	0	0	0	0	0	0	
	NL	NT	NR	NU	SL	ST	SR	SU	EL	ET	ER	EU	WL	WT	WR	WU	
7:00 AM	0	0	0	0	0	0	0	0	0	0	0	0	0	0	0	0	0
7:15 AM	0	0	0	0	0	0	0	0	0	0	0	0	0	0	0	0	0
7:30 AM	0	0	0	0	0	0	0	0	0	0	0	0	0	0	0	0	0
7:45 AM	0	0	0	0	0	0	0	0	0	0	0	0	0	0	0	0	0
8:00 AM	0	0	0	0	0	0	0	0	0	0	0	0	0	0	0	0	0
8:15 AM	0	0	0	0	0	0	0	0	0	0	0	0	0	0	0	0	0
8:30 AM	0	0	0	0	0	0	0	0	0	0	0	0	0	0	0	0	0
8:45 AM	0	0	0	0	0	0	0	0	0	0	0	0	0	0	0	0	0
<b>TOTAL VOLUMES :</b>	NL	NT	NR	NU	SL	ST	SR	SU	EL	ET	ER	EU	WL	WT	WR	WU	TOTAL
<b>APPROACH %'s :</b>	0	0	0	0	0	0	0	0	0	0	0	0	0	0	0	0	0
<b>PEAK HR :</b>	07:00 AM - 08:00 AM																TOTAL
<b>PEAK HR VOL :</b>	0	0	0	0	0	0	0	0	0	0	0	0	0	0	0	0	0
<b>PEAK HR FACTOR :</b>	0.000	0.000	0.000	0.000	0.000	0.000	0.000	0.000	0.000	0.000	0.000	0.000	0.000	0.000	0.000	0.000	0
<b>PM</b>	NORTHBOUND				SOUTHBOUND				EASTBOUND				WESTBOUND				TOTAL
	0	0	0	0	0	0	0	0	0	0	0	0	0	0	0	0	
	NL	NT	NR	NU	SL	ST	SR	SU	EL	ET	ER	EU	WL	WT	WR	WU	
4:00 PM	0	0	0	0	0	0	0	0	0	0	0	0	0	0	0	0	0
4:15 PM	0	0	0	0	0	0	0	0	0	0	0	0	0	0	0	0	0
4:30 PM	0	0	0	0	0	0	0	0	0	0	0	0	0	0	0	0	0
4:45 PM	0	0	0	0	0	0	0	0	0	0	0	0	0	1	0	0	1
5:00 PM	0	0	0	0	0	0	0	0	0	0	0	0	0	0	0	0	0
5:15 PM	0	0	0	0	0	0	0	0	0	0	0	0	0	0	0	0	0
5:30 PM	0	0	0	0	0	0	0	0	0	0	0	0	0	0	0	0	0
5:45 PM	0	0	0	0	0	0	0	0	0	0	0	0	0	0	0	0	0
<b>TOTAL VOLUMES :</b>	NL	NT	NR	NU	SL	ST	SR	SU	EL	ET	ER	EU	WL	WT	WR	WU	TOTAL
<b>APPROACH %'s :</b>	0	0	0	0	0	0	0	0	0	0	0	0	0.00%	100.00%	0.00%	0.00%	1
<b>PEAK HR :</b>	04:00 PM - 05:00 PM																TOTAL
<b>PEAK HR VOL :</b>	0	0	0	0	0	0	0	0	0	0	0	0	0	1	0	0	1
<b>PEAK HR FACTOR :</b>	0.000	0.000	0.000	0.000	0.000	0.000	0.000	0.000	0.000	0.000	0.000	0.000	0.000	0.250	0.000	0.000	0.250



### Garden Hwy & Tudor Rd

Date: 3/2/2022  
Day: Wednesday

Project #: Garden Hwy & Tudor Rd  
4180-01

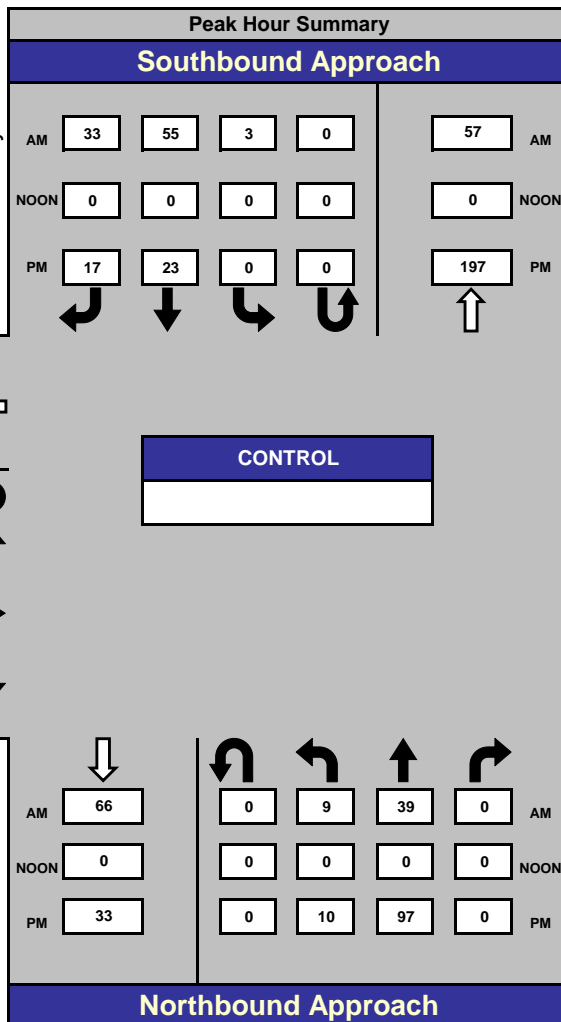

AM Peak Hour	07:30 - 08:30
NOON Peak Hour	12:00 - 13:00
PM Peak Hour	16:00 - 17:00

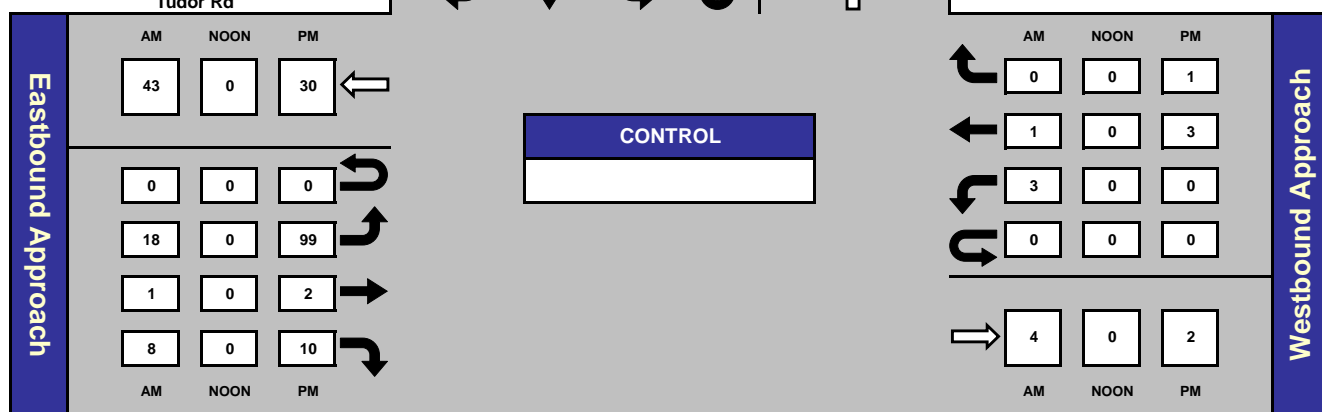

Count Periods	Start	End
AM	7:00 AM	9:00 AM
NOON	12:00 PM	1:00 PM
PM	4:00 PM	6:00 PM

### Total Ins & Outs

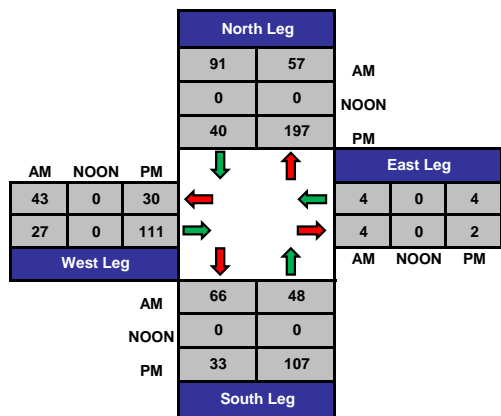

### Total Volume Per Leg

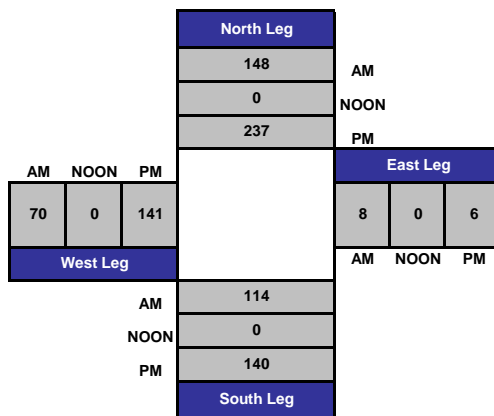

# ALL TRAFFIC DATA

4180-01

Sutter County  
All Vehicles & Uturns On Unshifted  
Bikes & Peds On Bank 1  
Nothing On Bank 2

(916) 771-8700  
[orders@atdtraffic.com](mailto:orders@atdtraffic.com)

File Name : Garden Hwy & Tudor Rd  
Date : 3/2/2022

## Unshifted Count = All Vehicles & Uturns

START TIME	Garden Hwy Southbound					Tudor Rd Westbound					Garden Hwy Northbound					Tudor Rd Eastbound					Total	Uturns Total
	LEFT	THRU	RIGHT	UTURNS	APP.TOTAL	LEFT	THRU	RIGHT	UTURNS	APP.TOTAL	LEFT	THRU	RIGHT	UTURNS	APP.TOTAL	LEFT	THRU	RIGHT	UTURNS	APP.TOTAL		
7:00	1	14	16	0	31	0	1	0	0	1	3	3	0	0	6	0	3	0	0	3	41	0
7:15	0	17	9	0	26	0	0	0	0	0	2	6	0	0	8	0	0	1	0	1	35	0
7:30	1	16	9	0	26	1	1	0	0	2	2	12	0	0	14	2	0	2	0	4	46	0
7:45	2	13	8	0	23	0	0	0	0	0	0	8	0	0	8	7	0	0	0	7	38	0
<b>Total</b>	<b>4</b>	<b>60</b>	<b>42</b>	<b>0</b>	<b>106</b>	<b>1</b>	<b>2</b>	<b>0</b>	<b>0</b>	<b>3</b>	<b>7</b>	<b>29</b>	<b>0</b>	<b>0</b>	<b>36</b>	<b>9</b>	<b>3</b>	<b>3</b>	<b>0</b>	<b>15</b>	<b>160</b>	<b>0</b>
8:00	0	12	10	0	22	2	0	0	0	2	5	7	0	0	12	5	0	5	0	10	46	0
8:15	0	14	6	0	20	0	0	0	0	0	2	12	0	0	14	4	1	1	0	6	40	0
8:30	0	10	1	0	11	0	0	0	0	0	2	5	0	0	7	3	0	2	0	5	23	0
8:45	2	8	9	0	19	0	0	1	0	1	3	11	0	0	14	1	1	3	0	5	39	0
<b>Total</b>	<b>2</b>	<b>44</b>	<b>26</b>	<b>0</b>	<b>72</b>	<b>2</b>	<b>0</b>	<b>1</b>	<b>0</b>	<b>3</b>	<b>12</b>	<b>35</b>	<b>0</b>	<b>0</b>	<b>47</b>	<b>13</b>	<b>2</b>	<b>11</b>	<b>0</b>	<b>26</b>	<b>148</b>	<b>0</b>
12:00	0	0	0	0	0	0	0	0	0	0	0	0	0	0	0	0	0	0	0	0	0	0
12:15	0	0	0	0	0	0	0	0	0	0	0	0	0	0	0	0	0	0	0	0	0	0
12:30	0	0	0	0	0	0	0	0	0	0	0	0	0	0	0	0	0	0	0	0	0	0
12:45	0	0	0	0	0	0	0	0	0	0	0	0	0	0	0	0	0	0	0	0	0	0
<b>Total</b>	<b>0</b>	<b>0</b>	<b>0</b>	<b>0</b>	<b>0</b>	<b>0</b>	<b>0</b>	<b>0</b>	<b>0</b>	<b>0</b>	<b>0</b>	<b>0</b>	<b>0</b>	<b>0</b>	<b>0</b>	<b>0</b>	<b>0</b>	<b>0</b>	<b>0</b>	<b>0</b>	<b>0</b>	<b>0</b>
16:00	0	8	6	0	14	0	2	0	0	2	4	25	0	0	29	34	1	2	0	37	82	0
16:15	0	6	5	0	11	0	1	0	0	1	2	18	0	0	20	26	1	7	0	34	66	0
16:30	0	6	3	0	9	0	0	1	0	1	3	31	0	0	34	13	0	1	0	14	58	0
16:45	0	3	3	0	6	0	0	0	0	0	1	23	0	0	24	26	0	0	0	26	56	0
<b>Total</b>	<b>0</b>	<b>23</b>	<b>17</b>	<b>0</b>	<b>40</b>	<b>0</b>	<b>3</b>	<b>1</b>	<b>0</b>	<b>4</b>	<b>10</b>	<b>97</b>	<b>0</b>	<b>0</b>	<b>107</b>	<b>99</b>	<b>2</b>	<b>10</b>	<b>0</b>	<b>111</b>	<b>262</b>	<b>0</b>
17:00	0	15	7	0	22	0	1	0	0	1	2	32	0	0	34	11	0	1	0	12	69	0
17:15	0	7	5	0	12	0	0	0	0	0	2	29	0	0	31	19	0	2	0	21	64	0
17:30	0	10	9	0	19	0	0	1	0	1	4	19	0	0	23	19	1	0	0	20	63	0
17:45	0	3	5	0	8	0	0	0	0	0	0	16	0	0	16	12	0	0	0	12	36	0
<b>Total</b>	<b>0</b>	<b>35</b>	<b>26</b>	<b>0</b>	<b>61</b>	<b>0</b>	<b>1</b>	<b>1</b>	<b>0</b>	<b>2</b>	<b>8</b>	<b>96</b>	<b>0</b>	<b>0</b>	<b>104</b>	<b>61</b>	<b>1</b>	<b>3</b>	<b>0</b>	<b>65</b>	<b>232</b>	<b>0</b>
Grand Total	6	162	111	0	279	3	6	3	0	12	37	257	0	0	294	182	8	27	0	217	802	0
Apprch %	2.2%	58.1%	39.8%	0.0%		25.0%	50.0%	25.0%	0.0%		12.6%	87.4%	0.0%	0.0%		83.9%	3.7%	12.4%	0.0%			
Total %	0.7%	20.2%	13.8%	0.0%	34.8%	0.4%	0.7%	0.4%	0.0%	1.5%	4.6%	32.0%	0.0%	0.0%	36.7%	22.7%	1.0%	3.4%	0.0%	27.1%	100.0%	

AM PEAK HOUR	Garden Hwy Southbound					Tudor Rd Westbound					Garden Hwy Northbound					Tudor Rd Eastbound					Total
	LEFT	THRU	RIGHT	UTURNS	APP.TOTAL	LEFT	THRU	RIGHT	UTURNS	APP.TOTAL	LEFT	THRU	RIGHT	UTURNS	APP.TOTAL	LEFT	THRU	RIGHT	UTURNS	APP.TOTAL	
Peak Hour Analysis From 07:30 to 08:30																					
Peak Hour For Entire Intersection Begins at 07:30																					
7:30	1	16	9	0	26	1	1	0	0	2	2	12	0	0	14	2	0	2	0	4	46
7:45	2	13	8	0	23	0	0	0	0	0	0	8	0	0	8	7	0	0	0	7	38
8:00	0	12	10	0	22	2	0	0	0	2	5	7	0	0	12	5	0	5	0	10	46
8:15	0	14	6	0	20	0	0	0	0	0	2	12	0	0	14	4	1	1	0	6	40
<b>Total Volume</b>	<b>3</b>	<b>55</b>	<b>33</b>	<b>0</b>	<b>91</b>	<b>3</b>	<b>1</b>	<b>0</b>	<b>0</b>	<b>4</b>	<b>9</b>	<b>39</b>	<b>0</b>	<b>0</b>	<b>48</b>	<b>18</b>	<b>1</b>	<b>8</b>	<b>0</b>	<b>27</b>	<b>170</b>
% App Total	3.3%	60.4%	36.3%	0.0%		75.0%	25.0%	0.0%	0.0%		18.8%	81.3%	0.0%	0.0%		66.7%	3.7%	29.6%	0.0%		
PHF	.375	.859	.825	.000	.875	.375	.250	.000	.000	.500	.450	.813	.000	.000	.857	.643	.250	.400	.000	.675	.924

NOON PEAK HOUR	Garden Hwy Southbound					Tudor Rd Westbound					Garden Hwy Northbound					Tudor Rd Eastbound					Total
	LEFT	THRU	RIGHT	UTURNS	APP.TOTAL	LEFT	THRU	RIGHT	UTURNS	APP.TOTAL	LEFT	THRU	RIGHT	UTURNS	APP.TOTAL	LEFT	THRU	RIGHT	UTURNS	APP.TOTAL	
Peak Hour Analysis From 12:00 to 13:00																					
Peak Hour For Entire Intersection Begins at 12:00																					
12:00 PM	0	0	0	0	0	0	0	0	0	0	0	0	0	0	0	0	0	0	0	0	0
12:15	0	0	0	0	0	0	0	0	0	0	0	0	0	0	0	0	0	0	0	0	0
12:30	0	0	0	0	0	0	0	0	0	0	0	0	0	0	0	0	0	0	0	0	0
12:45	0	0	0	0	0	0	0	0	0	0	0	0	0	0	0	0	0	0	0	0	0
<b>Total Volume</b>	<b>0</b>	<b>0</b>	<b>0</b>	<b>0</b>	<b>0</b>	<b>0</b>	<b>0</b>	<b>0</b>	<b>0</b>	<b>0</b>	<b>0</b>	<b>0</b>	<b>0</b>	<b>0</b>	<b>0</b>	<b>0</b>	<b>0</b>	<b>0</b>	<b>0</b>	<b>0</b>	<b>0</b>
% App Total	0.0%	0.0%	0.0%	0.0%		0.0%	0.0%	0.0%	0.0%		0.0%	0.0%	0.0%	0.0%		0.0%	0.0%	0.0%	0.0%		
PHF	.000	.000	.000	.000	.000	.000	.000	.000	.000	.000	.000	.000	.000	.000	.000	.000	.000	.000	.000	.000	.000

PM PEAK HOUR	Garden Hwy Southbound					Tudor Rd Westbound					Garden Hwy Northbound					Tudor Rd Eastbound					Total
	LEFT	THRU	RIGHT	UTURNS	APP.TOTAL	LEFT	THRU	RIGHT	UTURNS	APP.TOTAL	LEFT	THRU	RIGHT	UTURNS	APP.TOTAL	LEFT	THRU	RIGHT	UTURNS	APP.TOTAL	
Peak Hour Analysis From 16:00 to 17:00																					
Peak Hour For Entire Intersection Begins at 16:00																					
16:00	0	8	6	0	14	0	2	0	0	2	4	25	0	0	29	34	1	2	0	37	82
16:15	0	6	5	0	11	0	1	0	0	1	2	18	0	0	20	26	1	7	0	34	66
16:30	0	6	3	0	9	0	0	1	0	1	3	31	0	0	34	13	0	1	0	14	58
16:45	0	3	3	0	6	0	0	0	0	0	1	23	0	0	24	26	0	0	0	26	56
<b>Total Volume</b>	<b>0</b>	<b>23</b>	<b>17</b>	<b>0</b>	<b>40</b>	<b>0</b>	<b>3</b>	<b>1</b>	<b>0</b>	<b>4</b>	<b>10</b>	<b>97</b>	<b>0</b>	<b>0</b>	<b>107</b>	<b>99</b>	<b>2</b>	<b>10</b>	<b>0</b>	<b>111</b>	<b>262</b>
% App Total	0.0%	57.5%	42.5%	0.0%		0.0%	75.0%	25.0%	0.0%		9.3%	90.7%	0.0%	0.0%		89.2%	1.8%	9.0%	0.0%		
PHF	.000	.719	.708	.000	.714	.000	.375	.250	.000	.500	.625	.782	.000	.000	.787	.728	.500	.357	.000	.750	.799

### Garden Hwy & Tudor Rd - Trucks

Date: 3/2/2022  
Day: Wednesday

Project #: Garden Hwy & Tudor Rd - Trucks  
4180-01

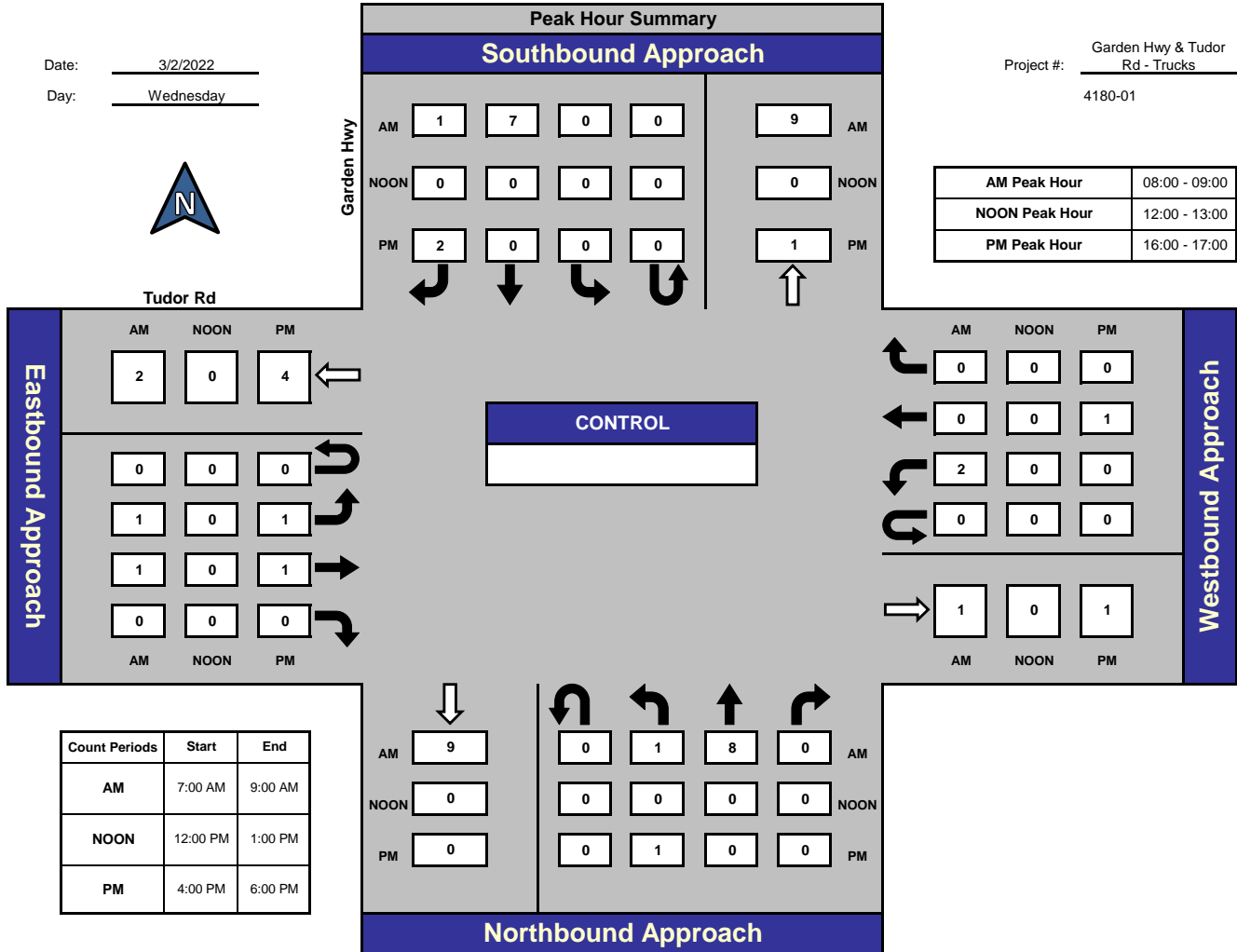

**Total Ins & Outs**

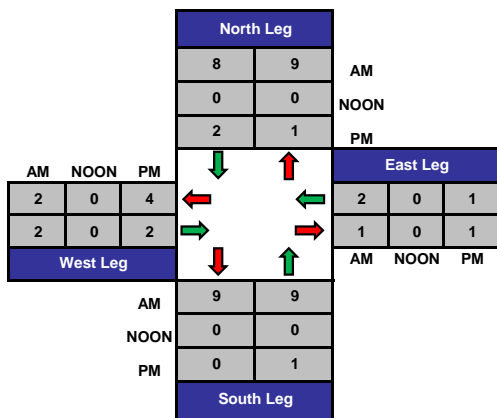

**Total Volume Per Leg**

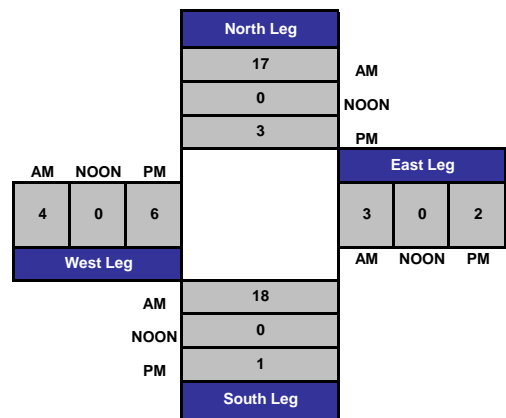

**ALL TRAFFIC DATA**

4180-01

**Trucks**

Sutter County  
All Vehicles & Uturns On Unshifted  
Bikes & Peds On Bank 1  
Nothing On Bank 2

(916) 771-8700

[orders@atdtraffic.com](mailto:orders@atdtraffic.com)

File Name : Garden Hwy & Tudor Rd - Trucks

Date : 3/2/2022

**Unshifted Count = All Vehicles & Uturns**

START TIME	Garden Hwy Southbound					Tudor Rd Westbound					Garden Hwy Northbound					Tudor Rd Eastbound					Total	Uturns Total	
	LEFT	THRU	RIGHT	UTURNS	APP.TOTAL	LEFT	THRU	RIGHT	UTURNS	APP.TOTAL	LEFT	THRU	RIGHT	UTURNS	APP.TOTAL	LEFT	THRU	RIGHT	UTURNS	APP.TOTAL			
7:00	0	2	0	0	2	0	0	0	0	0	0	0	0	0	0	0	0	0	0	0	0	2	0
7:15	0	0	0	0	0	0	0	0	0	0	1	0	0	0	1	0	0	0	0	0	0	1	0
7:30	0	0	0	0	0	1	1	0	0	2	0	0	0	0	0	0	0	0	0	0	0	2	0
7:45	0	0	0	0	0	0	0	0	0	0	0	0	0	0	0	0	0	0	0	0	0	0	0
Total	0	2	0	0	2	1	1	0	0	2	1	0	0	0	1	0	0	0	0	0	0	5	0
8:00	0	0	0	0	0	2	0	0	0	2	0	0	0	0	0	1	0	0	0	1	3	0	
8:15	0	1	0	0	1	0	0	0	0	0	0	6	0	6	0	0	0	0	0	0	7	0	
8:30	0	5	1	0	6	0	0	0	0	0	0	1	0	1	0	0	0	0	0	0	7	0	
8:45	0	1	0	0	1	0	0	0	0	0	1	1	0	2	0	1	0	0	0	1	4	0	
Total	0	7	1	0	8	2	0	0	0	2	1	8	0	9	1	1	0	0	0	2	21	0	
12:00	0	0	0	0	0	0	0	0	0	0	0	0	0	0	0	0	0	0	0	0	0	0	
12:15	0	0	0	0	0	0	0	0	0	0	0	0	0	0	0	0	0	0	0	0	0	0	
12:30	0	0	0	0	0	0	0	0	0	0	0	0	0	0	0	0	0	0	0	0	0	0	
12:45	0	0	0	0	0	0	0	0	0	0	0	0	0	0	0	0	0	0	0	0	0	0	
Total	0	0	0	0	0	0	0	0	0	0	0	0	0	0	0	0	0	0	0	0	0	0	
16:00	0	0	0	0	0	0	1	0	0	1	0	0	0	0	0	0	1	0	0	0	1	2	0
16:15	0	0	1	0	1	0	0	0	0	0	1	0	0	0	1	0	0	0	0	0	0	2	0
16:30	0	0	0	0	0	0	0	0	0	0	0	0	0	0	0	0	0	0	0	0	0	0	0
16:45	0	0	1	0	1	0	0	0	0	0	0	0	0	0	0	1	0	0	0	0	1	2	0
Total	0	0	2	0	2	0	1	0	0	1	1	0	0	0	1	1	1	0	0	0	2	6	0
17:00	0	0	0	0	0	0	0	0	0	0	0	0	0	0	0	0	0	0	0	0	0	0	0
17:15	0	0	0	0	0	0	0	0	0	0	0	1	0	1	0	0	0	0	0	0	1	0	0
17:30	0	0	0	0	0	0	0	0	0	0	0	0	0	0	1	1	0	0	0	2	2	0	
17:45	0	0	0	0	0	0	0	0	0	0	0	0	0	0	1	0	0	0	0	1	1	0	0
Total	0	0	0	0	0	0	0	0	0	0	0	1	0	1	2	1	0	0	0	3	4	0	0
Grand Total	0	9	3	0	12	3	2	0	0	5	3	9	0	12	4	3	0	0	0	7	36	0	
Apprch %	0.0%	75.0%	25.0%	0.0%		60.0%	40.0%	0.0%	0.0%		25.0%	75.0%	0.0%	0.0%		57.1%	42.9%	0.0%	0.0%				
Total %	0.0%	25.0%	8.3%	0.0%	33.3%	8.3%	5.6%	0.0%	0.0%	13.9%	8.3%	25.0%	0.0%	0.0%	33.3%	11.1%	8.3%	0.0%	0.0%	19.4%	100.0%		

AM PEAK HOUR	Garden Hwy Southbound					Tudor Rd Westbound					Garden Hwy Northbound					Tudor Rd Eastbound					Total	
	LEFT	THRU	RIGHT	UTURNS	APP.TOTAL	LEFT	THRU	RIGHT	UTURNS	APP.TOTAL	LEFT	THRU	RIGHT	UTURNS	APP.TOTAL	LEFT	THRU	RIGHT	UTURNS	APP.TOTAL		
Peak Hour Analysis From 08:00 to 09:00																						
Peak Hour For Entire Intersection Begins at 08:00																						
8:00	0	0	0	0	0	2	0	0	0	2	0	0	0	0	0	1	0	0	0	1	3	0
8:15	0	1	0	0	1	0	0	0	0	0	0	6	0	6	0	0	0	0	0	0	7	0
8:30	0	5	1	0	6	0	0	0	0	0	0	1	0	1	0	0	0	0	0	0	7	0
8:45	0	1	0	0	1	0	0	0	0	0	1	1	0	2	0	1	0	0	0	1	4	0
Total Volume	0	7	1	0	8	2	0	0	0	2	1	8	0	9	1	1	0	0	0	2	21	0
% App Total	0.0%	87.5%	12.5%	0.0%		100.0%	0.0%	0.0%	0.0%		11.1%	88.9%	0.0%	0.0%		50.0%	50.0%	0.0%	0.0%			
PHF	.000	.350	.250	.000	.333	.250	.000	.000	.000	.250	.250	.333	.000	.000	.375	.250	.250	.000	.000	.500	.750	

NOON PEAK HOUR	Garden Hwy Southbound					Tudor Rd Westbound					Garden Hwy Northbound					Tudor Rd Eastbound					Total	
	LEFT	THRU	RIGHT	UTURNS	APP.TOTAL	LEFT	THRU	RIGHT	UTURNS	APP.TOTAL	LEFT	THRU	RIGHT	UTURNS	APP.TOTAL	LEFT	THRU	RIGHT	UTURNS	APP.TOTAL		
Peak Hour Analysis From 12:00 to 13:00																						
Peak Hour For Entire Intersection Begins at 12:00																						
12:00 PM	0	0	0	0	0	0	0	0	0	0	0	0	0	0	0	0	0	0	0	0	0	0
12:15	0	0	0	0	0	0	0	0	0	0	0	0	0	0	0	0	0	0	0	0	0	0
12:30	0	0	0	0	0	0	0	0	0	0	0	0	0	0	0	0	0	0	0	0	0	0
12:45	0	0	0	0	0	0	0	0	0	0	0	0	0	0	0	0	0	0	0	0	0	0
Total Volume	0	0	0	0	0	0	0	0	0	0	0	0	0	0	0	0	0	0	0	0	0	0
% App Total	0.0%	0.0%	0.0%	0.0%		0.0%	0.0%	0.0%	0.0%		0.0%	0.0%	0.0%	0.0%		0.0%	0.0%	0.0%	0.0%			
PHF	.000	.000	.000	.000	.000	.000	.000	.000	.000	.000	.000	.000	.000	.000	.000	.000	.000	.000	.000	.000	.000	.000

PM PEAK HOUR	Garden Hwy Southbound					Tudor Rd Westbound					Garden Hwy Northbound					Tudor Rd Eastbound					Total	
	LEFT	THRU	RIGHT	UTURNS	APP.TOTAL	LEFT	THRU	RIGHT	UTURNS	APP.TOTAL	LEFT	THRU	RIGHT	UTURNS	APP.TOTAL	LEFT	THRU	RIGHT	UTURNS	APP.TOTAL		
Peak Hour Analysis From 16:00 to 17:00																						
Peak Hour For Entire Intersection Begins at 16:00																						
16:00	0	0	0	0	0	0	1	0	0	1	0	0	0	0	0	0	1	0	0	0	1	2
16:15	0	0	1	0	1	0	0	0	0	0	1	0	0	0	1	0	0	0	0	0	0	2
16:30	0	0	0	0	0	0	0	0	0	0	0	0	0	0	0	0	0	0	0	0	0	0
16:45	0	0	1	0	1	0	0	0	0	0	0	0	0	0	0	1	0	0	0	0	1	2
Total Volume	0	0	2	0	2	0	1	0	0	1	1	0	0	0	1	1	1	0	0	0	2	6
% App Total	0.0%	0.0%	100.0%	0.0%		0.0%	100.0%	0.0%	0.0%		100.0%	0.0%	0.0%	0.0%		50.0%	50.0%	0.0%	0.0%			
PHF	.000	.000	.500	.000	.500	.000	.250	.000	.000	.250	.250	.000	.000	.000	.250	.250	.250	.000	.000	.500	.750	



**03-SUT-099 PM R17.489 / Wilson Rd  
Yuba City, CA**

Count and warrant worksheet V2.4 (24 hour summary)

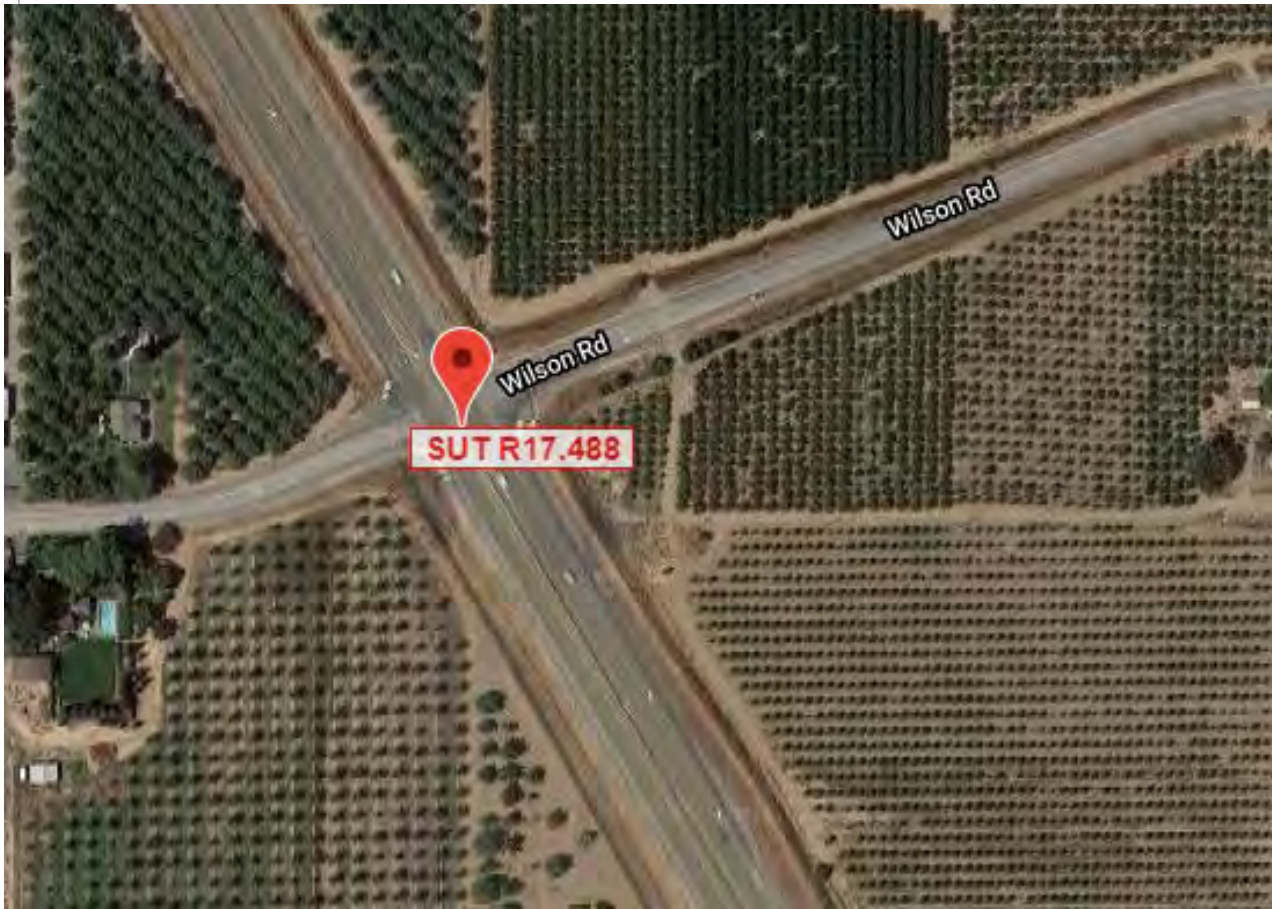

Notes  
 Classification  
 0.3% Motorcycles  
 67.1% Cars  
 22.2% Light Goods Vehicles  
 0.2% Buses  
 2.6% Single Unit Trucks  
 7.6% Tractor Trailers

ADTs and Truck %  
 North Leg: 16663 10%  
 South Leg: 17544 10.5%  
 East Leg: 1089 3%  
 West Leg: 318 7.9%

Above values are for 15 hour period

Morning Interval	Miovision Cameras						sunny						Thursday, 05 March 2020								
Begin End	SBR	SBT	SBL	Ped	Total	WBR	WBT	WBL	Ped	Total	NBR	NBT	NBL	Ped	Total	EBR	EBT	EBL	Ped	Total	All Total
6:00 - 6:15	2	254	0	0	256	0	0	11	0	11	3	62	3	0	68						335
6:15 - 6:30	0	311	0	0	311	0	2	23	0	25	2	71	0	0	73	1	0	2	0	3	412
6:30 - 6:45	1	260	0	0	261	1	1	26	0	28	8	89	0	0	97	1	0	0	0	1	387
6:45 - 7:00	0	227	0	0	227	0	0	20	0	20	3	94	1	0	98	1	2	2	0	5	350
<b>Total</b>	<b>3</b>	<b>1052</b>			<b>1055</b>	<b>1</b>	<b>3</b>	<b>80</b>		<b>84</b>	<b>16</b>	<b>316</b>	<b>4</b>		<b>336</b>	<b>3</b>	<b>2</b>	<b>4</b>		<b>9</b>	<b>1484</b>
7:00 - 7:15	2	202	0	0	204	0	2	15	0	17	3	107	0	0	110	1	1	6	0	8	339
7:15 - 7:30	0	220	0	0	220	0	0	13	0	13	9	112	0	0	121	3	0	2	0	5	359
7:30 - 7:45	3	168	0	0	171	0	1	18	0	19	9	136	3	0	148						338
7:45 - 8:00	2	166	0	0	168	1	0	14	0	15	6	114	1	0	121	2	0	2	0	4	308
<b>Total</b>	<b>7</b>	<b>756</b>			<b>763</b>	<b>1</b>	<b>3</b>	<b>60</b>		<b>64</b>	<b>27</b>	<b>469</b>	<b>4</b>		<b>500</b>	<b>6</b>	<b>1</b>	<b>10</b>		<b>17</b>	<b>1344</b>
8:00 - 8:15	2	163	0	0	165	0	1	18	0	19	8	119	0	0	127	1	1	1	0	3	314
8:15 - 8:30	0	169	0	0	169	0	1	12	0	13	7	118	0	0	125	0	0	1	0	1	308
8:30 - 8:45	1	168	0	0	169	0	1	11	0	12	4	131	3	0	138	2	1	0	0	3	322
8:45 - 9:00	1	161	1	0	163	0	0	3	0	3	2	107	0	0	109	0	2	0	0	2	277
<b>Total</b>	<b>4</b>	<b>661</b>	<b>1</b>		<b>666</b>		<b>3</b>	<b>44</b>		<b>47</b>	<b>21</b>	<b>475</b>	<b>3</b>		<b>499</b>	<b>3</b>	<b>4</b>	<b>2</b>		<b>9</b>	<b>1221</b>
9:00 - 9:15	1	149	1	0	151	0	0	7	0	7	2	89	0	0	91	1	0	1	0	2	251
9:15 - 9:30	0	151	0	0	151	1	0	8	0	9	5	105	1	0	111	1	0	1	0	2	273
9:30 - 9:45	0	126	0	0	126	0	2	4	0	6	3	108	1	0	112						244
9:45 - 10:00	1	121	1	0	123	1	0	8	0	9	2	119	0	0	121	1	0	1	0	2	255
<b>Total</b>	<b>2</b>	<b>547</b>	<b>2</b>		<b>551</b>	<b>2</b>	<b>2</b>	<b>27</b>		<b>31</b>	<b>12</b>	<b>421</b>	<b>2</b>		<b>435</b>	<b>3</b>		<b>3</b>		<b>6</b>	<b>1023</b>
Peak 15 Min.																					
6:15 - 6:30	0	311	0	0	311	0	2	23	0	25	2	71	0	0	73	1	0	2	0	3	412
Peak Hour																					
6:05 - 7:05	4	1039	0	0	1043	1	4	84	0	89	17	329	2	0	348	4	3	5	0	12	1492
PHF	0.50	0.83	#####		0.83	0.25	0.50	0.81		0.79	0.53	0.83	0.50		0.83	0.50	0.38	0.42		0.50	0.91
Truck %	0.0%	6.0%	#####		5.9%	0.0%	0.0%	2.4%		2.2%	5.9%	24.0%	50.0%		23.3%	25.0%	0.0%	0.0%		8.3%	9.8%

Midday Interval		Miovision Cameras										sunny					Thursday, 05 March 2020					
Begin	End	SBR	SBT	SBL	Ped	Total	WBR	WBT	WBL	Ped	Total	NBR	NBT	NBL	Ped	Total	EBR	EBT	EBL	Ped	Total	All Total
10:00 - 10:15		4	111	0	0	115	0	1	6	0	7	3	86	1	0	90	1	1	1	0	3	215
10:15 - 10:30		1	152	0	0	153	0	2	6	0	8	5	81	0	0	86	0	1	1	0	2	249
10:30 - 10:45		2	115	1	2	118	1	1	3	2	5	4	102	3	2	109	1	1	0	2	2	234
10:45 - 11:00		0	104	0	0	104	0	0	12	0	12	1	109	0	0	110	0	1	3	0	4	230
Total		7	482	1	2	490	1	4	27	2	32	13	378	4	2	395	2	4	5	2	11	928
11:00 - 11:15		2	125	0	0	127	0	0	9	0	9	2	108	1	0	111	0	1	2	0	3	250
11:15 - 11:30		1	112	1	0	114	0	1	2	0	3	2	87	2	0	91	1	0	0	0	1	209
11:30 - 11:45		3	119	0	0	122	1	1	3	0	5	3	124	1	0	128						255
11:45 - 12:00		0	127	1	0	128	0	2	8	0	10	1	119	1	1	121	2	3	1	0	6	265
Total		6	483	2		491	1	4	22		27	8	438	5	1	451	3	4	3		10	979
12:00 - 12:15		0	116	1	0	117	1	1	2	0	4	5	105	0	0	110	0	2	3	0	5	236
12:15 - 12:30		2	135	0	0	137	0	0	3	0	3	5	99	0	0	104	1	1	4	0	6	250
12:30 - 12:45		0	125	0	0	125	0	0	5	0	5	9	127	2	0	138	0	2	2	0	4	272
12:45 - 13:00		2	122	0	0	124	2	1	4	0	7	8	117	0	0	125	2	0	1	0	3	259
Total		4	498	1		503	3	2	14		19	27	448	2		477	3	5	10		18	1017
13:00 - 13:15		2	118	0	0	120	0	2	6	0	8	6	117	2	0	125	3	0	1	0	4	257
13:15 - 13:30		0	121	0	0	121	1	2	5	0	8	9	118	1	0	128	1	0	1	0	2	259
13:30 - 13:45		1	132	1	0	134	0	0	7	0	7	2	122	1	0	125	3	2	2	0	7	273
13:45 - 14:00		2	113	0	0	115	1	1	4	0	6	7	105	1	0	113	0	1	3	0	4	238
Total		5	484	1		490	2	5	22		29	24	462	5		491	7	3	7		17	1027
Peak 15 Min.																						
13:25 - 13:40		1	149	0	0	150	0	2	8	0	10	2	126	2	0	130	2	1	2	0	5	295
Peak Hour																						
12:40 - 13:40		5	508	0	0	513	3	5	21	0	29	30	473	4	0	507	8	1	5	0	14	1063
PHF		0.63	0.85	#####		0.86	0.38	0.63	0.66		0.73	0.68	0.89	0.50		0.91	0.67	0.25	0.63		0.70	0.90
Truck %		20.0%	17.9%	#####		17.9%	0.0%	0.0%	4.8%		3.4%	6.7%	14.8%	25.0%		14.4%	0.0%	0.0%	0.0%		0.0%	15.6%

Evening Interval		Miovision Cameras										sunny					Thursday, 05 March 2020					
Begin	End	SBR	SBT	SBL	Ped	Total	WBR	WBT	WBL	Ped	Total	NBR	NBT	NBL	Ped	Total	EBR	EBT	EBL	Ped	Total	All Total
14:00 - 14:15		2	137	0	0	139	1	1	10	0	12	5	139	0	0	144						295
14:15 - 14:30		0	134	4	0	138	1	0	4	0	5	8	143	1	0	152	1	1	4	0	6	301
14:30 - 14:45		2	130	1	0	133	0	0	9	0	9	13	175	0	0	188	1	0	2	0	3	333
14:45 - 15:00		2	151	1	0	154	0	0	3	0	3	14	166	1	0	181						338
Total		6	552	6		564	2	1	26		29	40	623	2		665	2	1	6		9	1267
15:00 - 15:15		1	130	0	0	131	0	0	4	0	4	23	204	1	0	228	1	1	2	0	4	367
15:15 - 15:30		2	138	1	0	141	1	2	7	0	10	16	180	0	0	196	1	0	4	0	5	352
15:30 - 15:45		2	127	1	0	130	2	0	7	0	9	22	217	0	0	239	1	0	2	0	3	381
15:45 - 16:00		0	147	0	0	147	2	1	6	0	9	23	261	0	0	284	2	0	1	0	3	443
Total		5	542	2		549	5	3	24		32	84	862	1		947	5	1	9		15	1543
16:00 - 16:15		1	145	1	0	147	2	1	4	0	7	24	250	3	0	277	1	3	1	0	5	436
16:15 - 16:30		0	144	0	0	144	0	0	5	0	5	20	232	1	0	253	0	1	0	0	1	403
16:30 - 16:45		2	129	1	0	132	1	1	7	0	9	27	260	1	0	288	2	0	0	0	2	431
16:45 - 17:00		2	145	0	0	147	0	1	4	0	5	32	266	1	0	299	3	1	1	0	5	456
Total		5	563	2		570	3	3	20		26	103	1008	6		1117	6	5	2		13	1726
17:00 - 17:15		3	132	0	0	135	0	0	2	0	2	24	224	1	0	249	0	3	1	0	4	390
17:15 - 17:30		2	148	0	0	150	0	0	15	0	15	17	225	0	0	242	2	0	1	0	3	410
17:30 - 17:45		2	152	2	0	156	0	0	6	0	6	16	230	2	0	248	1	0	0	0	1	411
17:45 - 18:00		1	161	0	0	162	0	0	2	0	2	24	241	0	0	265	2	0	1	0	3	432
Total		8	593	2		603			25		25	81	920	3		1004	5	3	3		11	1643
Peak 15 Min.																						
16:35 - 16:50		1	141	0	0	142	1	1	4	0	6	40	270	1	0	311	1	1	0	0	2	461
Peak Hour																						
15:50 - 16:50		3	569	2	0	574	5	4	20	0	29	103	1007	5	0	1115	5	5	2	0	12	1730
PHF		0.38	0.89	0.50		0.90	0.63	1.00	0.50		0.60	0.64	0.93	0.42		0.90	0.63	0.42	0.50		0.60	0.94
Truck %		0.0%	9.7%	0.0%		9.6%	0.0%	0.0%	10.0%		6.9%	2.9%	4.8%	20.0%		4.7%	20.0%	0.0%	0.0%		8.3%	6.4%

12 hour truck % and Total Pedestrian	6.5%	12.1%	5.0%	2	12.0%	4.8%	6.1%	2.8%	2	3.1%	3.7%	11.5%	9.8%	3	11.0%	12.5%	3.0%	4.7%	2	6.9%	11.2%
--------------------------------------	------	-------	------	---	-------	------	------	------	---	------	------	-------	------	---	-------	-------	------	------	---	------	-------



**03-SUT-099 PM R17.489 / Wilson Rd  
Yuba City, CA**

AM Overnight	Miovision Cameras										dark					Thursday, 05 March 2020					
Begin End	SBR	SBT	SBL	Ped	Total	WBR	WBT	WBL	Ped	Total	NBR	NBT	NBL	Ped	Total	EBR	EBT	EBL	Ped	Total	All Total
18:00 - 18:15	3	127	0	0	130	2	0	5	0	7	21	238	1	0	260	1	1	0	0	2	399
18:15 - 18:30	1	116	0	0	117	0	0	4	0	4	12	188	2	0	202						323
18:30 - 18:45	2	87	1	0	90	0	1	4	0	5	9	167	0	0	176	0	1	1	0	2	273
18:45 - 19:00	1	93	0	0	94	0	1	3	0	4	17	159	2	0	178	0	0	2	0	2	278
<b>Total</b>	<b>7</b>	<b>423</b>	<b>1</b>		<b>431</b>	<b>2</b>	<b>2</b>	<b>16</b>		<b>20</b>	<b>59</b>	<b>752</b>	<b>5</b>		<b>816</b>	<b>1</b>	<b>2</b>	<b>3</b>		<b>6</b>	<b>1273</b>
19:00 - 19:15	0	75	0	0	75	0	1	2	0	3	4	116	1	0	121	0	0	2	0	2	201
19:15 - 19:30	1	64	0	0	65	0	0	2	0	2	6	115	0	0	121						188
19:30 - 19:45	1	62	0	0	63	0	0	3	0	3	8	114	0	0	122	0	0	1	0	1	189
19:45 - 20:00	0	68	0	0	68	0	0	3	0	3	3	94	0	0	97						168
<b>Total</b>	<b>2</b>	<b>269</b>			<b>271</b>		<b>1</b>	<b>10</b>		<b>11</b>	<b>21</b>	<b>439</b>	<b>1</b>		<b>461</b>			<b>3</b>		<b>3</b>	<b>746</b>
20:00 - 20:15	0	64	0	0	64						5	83	1	0	89						153
20:15 - 20:30	2	55	0	0	57	0	0	3	0	3	2	108	1	0	111						171
20:30 - 20:45	2	58	0	0	60	0	0	1	0	1	3	72	1	0	76	0	1	1	0	2	139
20:45 - 21:00	0	42	0	0	42	0	1	1	0	2	4	75	0	0	79						123
<b>Total</b>	<b>4</b>	<b>219</b>			<b>223</b>		<b>1</b>	<b>5</b>		<b>6</b>	<b>14</b>	<b>338</b>	<b>3</b>		<b>355</b>		<b>1</b>	<b>1</b>		<b>2</b>	<b>586</b>
21:00 - 21:15																					
21:15 - 21:30																					
21:30 - 21:45																					
21:45 - 22:00																					
<b>Total</b>																					
22:00 - 22:15																					
22:15 - 22:30																					
22:30 - 22:45																					
22:45 - 23:00																					
<b>Total</b>																					
23:00 - 23:15																					
23:15 - 23:30																					
23:30 - 23:45																					
23:45 - 6:00																					
<b>Total</b>																					
<b>Peak 15 Min.</b>																					
18:00 - 18:15	3	127	0	0	130	2	0	5	0	7	21	238	1	0	260	1	1	0	0	2	399
<b>Peak Hour</b>																					
18:00 - 19:00	7	423	1	0	431	2	2	16	0	20	59	752	5	0	816	1	2	3	0	6	1273
<b>PHF</b>	0.58	0.82	0.25		0.83	0.25	0.25	0.80		0.71	0.70	0.79	0.63		0.78	0.25	0.50	0.25		0.50	0.80
<b>Truck %</b>	14.3%	8.3%	0.0%		8.4%	0.0%	0.0%	0.0%		0.0%	0.0%	5.2%	20.0%		4.9%	0.0%	0.0%	33.3%		16.7%	6.0%

PM Overnight		Miovision Cameras										dark					Tuesday, 24 September 2019					
Begin	End	SBR	SBT	SBL	Ped	Total	WBR	WBT	WBL	Ped	Total	NBR	NBT	NBL	Ped	Total	EBR	EBT	EBL	Ped	Total	All Total
18:00 - 18:15																						
18:15 - 18:30																						
18:30 - 18:45																						
18:45 - 19:00																						
Total																						
19:00 - 19:15																						
19:15 - 19:30																						
19:30 - 19:45																						
19:45 - 20:00																						
Total																						
20:00 - 20:15																						
20:15 - 20:30																						
20:30 - 20:45																						
20:45 - 21:00																						
Total																						
21:00 - 21:15																						
21:15 - 21:30																						
21:30 - 21:45																						
21:45 - 22:00																						
Total																						
22:00 - 22:15																						
22:15 - 22:30																						
22:30 - 22:45																						
22:45 - 23:00																						
Total																						
23:00 - 23:15																						
23:15 - 23:30																						
23:30 - 23:45																						
23:45 - 0:00																						
Total																						
Peak 15 Min.																						
0:00 - 0:15		#N/A	#N/A	#N/A	#N/A	#N/A	#N/A	#N/A	#N/A	#N/A	#N/A	#N/A	#N/A	#N/A	#N/A	#N/A	#N/A	#N/A	#N/A	#N/A	#N/A	#N/A
Peak Hour																						
0:00 - 1:00		#N/A	#N/A	#N/A	#N/A	#N/A	#N/A	#N/A	#N/A	#N/A	#N/A	#N/A	#N/A	#N/A	#N/A	#N/A	#N/A	#N/A	#N/A	#N/A	#N/A	#N/A
PHF		0.00	0.00	0.00		0.00	0.00	0.00		0.00	0.00	0.00	0.00		0.00	0.00	0.00	0.00		0.00	0.00	
Truck %		0.0%	0.0%	0.0%		0.0%	0.0%	0.0%		0.0%	0.0%	0.0%	0.0%		0.0%	0.0%	0.0%	0.0%		0.0%	0.0%	

12 hour truck % and Total Pedestrian	15.4%	8.2%	0.0%	0	8.3%	0.0%	0.0%	0.0%	0	0.0%	0.0%	4.6%	11.1%	0	4.4%	0.0%	0.0%	28.6%	0	18.2%	5.8%
--------------------------------------	-------	------	------	---	------	------	------	------	---	------	------	------	-------	---	------	------	------	-------	---	-------	------



Intersection	
Intersection Delay, s/veh	7.9
Intersection LOS	A

Movement	EBL	EBT	EBR	WBL	WBT	WBR	NBL	NBT	NBR	SBL	SBT	SBR
Lane Configurations		↕			↕		↕	↕		↕	↕	↕
Traffic Vol, veh/h	18	1	8	3	1	0	9	39	0	3	55	33
Future Vol, veh/h	18	1	8	3	1	0	9	39	0	3	55	33
Peak Hour Factor	0.92	0.92	0.92	0.92	0.92	0.92	0.92	0.92	0.92	0.92	0.92	0.92
Heavy Vehicles, %	6	100	2	67	2	2	11	21	2	2	13	3
Mvmt Flow	20	1	9	3	1	0	10	42	0	3	60	36
Number of Lanes	0	1	0	0	1	0	1	1	0	1	1	1

Approach	EB	WB	NB	SB
Opposing Approach	WB	EB	SB	NB
Opposing Lanes	1	1	3	2
Conflicting Approach Left	SB	NB	EB	WB
Conflicting Lanes Left	3	2	1	1
Conflicting Approach Right	NB	SB	WB	EB
Conflicting Lanes Right	2	3	1	1
HCM Control Delay	8	9.2	8.2	7.6
HCM LOS	A	A	A	A

Lane	NBLn1	NBLn2	EBLn1	WBLn1	SBLn1	SBLn2	SBLn3
Vol Left, %	100%	0%	67%	75%	100%	0%	0%
Vol Thru, %	0%	100%	4%	25%	0%	100%	0%
Vol Right, %	0%	0%	30%	0%	0%	0%	100%
Sign Control	Stop	Stop	Stop	Stop	Stop	Stop	Stop
Traffic Vol by Lane	9	39	27	4	3	55	33
LT Vol	9	0	18	3	3	0	0
Through Vol	0	39	1	1	0	55	0
RT Vol	0	0	8	0	0	0	33
Lane Flow Rate	10	42	29	4	3	60	36
Geometry Grp	8	8	7	7	7	7	7
Degree of Util (X)	0.015	0.06	0.042	0.008	0.005	0.08	0.039
Departure Headway (Hd)	5.383	5.053	5.092	6.402	5.12	4.807	3.936
Convergence, Y/N	Yes	Yes	Yes	Yes	Yes	Yes	Yes
Cap	657	699	708	562	696	741	902
Service Time	3.181	2.85	2.792	4.103	2.876	2.563	1.692
HCM Lane V/C Ratio	0.015	0.06	0.041	0.007	0.004	0.081	0.04
HCM Control Delay	8.3	8.2	8	9.2	7.9	8	6.9
HCM Lane LOS	A	A	A	A	A	A	A
HCM 95th-tile Q	0	0.2	0.1	0	0	0.3	0.1

Intersection	
Intersection Delay, s/veh	9
Intersection LOS	A

Movement	EBL	EBT	EBR	WBL	WBT	WBR	NBL	NBT	NBR	SBL	SBT	SBR
Lane Configurations		↕			↕		↕	↕		↕	↕	↕
Traffic Vol, veh/h	99	2	10	0	3	1	10	97	0	0	23	17
Future Vol, veh/h	99	2	10	0	3	1	10	97	0	0	23	17
Peak Hour Factor	0.80	0.80	0.80	0.80	0.80	0.80	0.80	0.80	0.80	0.80	0.80	0.80
Heavy Vehicles, %	2	50	2	2	33	2	10	2	2	2	2	12
Mvmt Flow	124	3	13	0	4	1	13	121	0	0	29	21
Number of Lanes	0	1	0	0	1	0	1	1	0	1	1	1

Approach	EB	WB	NB	SB
Opposing Approach	WB	EB	SB	NB
Opposing Lanes	1	1	3	2
Conflicting Approach Left	SB	NB	EB	WB
Conflicting Lanes Left	3	2	1	1
Conflicting Approach Right	NB	SB	WB	EB
Conflicting Lanes Right	2	3	1	1
HCM Control Delay	9.5	8.3	8.9	7.7
HCM LOS	A	A	A	A

Lane	NBLn1	NBLn2	EBLn1	WBLn1	SBLn1	SBLn2	SBLn3
Vol Left, %	100%	0%	89%	0%	0%	0%	0%
Vol Thru, %	0%	100%	2%	75%	100%	100%	0%
Vol Right, %	0%	0%	9%	25%	0%	0%	100%
Sign Control	Stop	Stop	Stop	Stop	Stop	Stop	Stop
Traffic Vol by Lane	10	97	111	4	0	23	17
LT Vol	10	0	99	0	0	0	0
Through Vol	0	97	2	3	0	23	0
RT Vol	0	0	10	1	0	0	17
Lane Flow Rate	12	121	139	5	0	29	21
Geometry Grp	8	8	7	7	7	7	7
Degree of Util (X)	0.02	0.171	0.208	0.008	0	0.041	0.027
Departure Headway (Hd)	5.729	5.09	5.385	5.497	5.074	5.074	4.541
Convergence, Y/N	Yes	Yes	Yes	Yes	Yes	Yes	Yes
Cap	627	707	667	652	0	707	790
Service Time	3.448	2.809	3.106	3.223	2.794	2.794	2.261
HCM Lane V/C Ratio	0.019	0.171	0.208	0.008	0	0.041	0.027
HCM Control Delay	8.6	8.9	9.5	8.3	7.8	8	7.4
HCM Lane LOS	A	A	A	A	N	A	A
HCM 95th-tile Q	0.1	0.6	0.8	0	0	0.1	0.1

Intersection	
Intersection Delay, s/veh	8.1
Intersection LOS	A

Movement	EBL	EBT	EBR	WBL	WBT	WBR	NBL	NBT	NBR	SBL	SBT	SBR
Lane Configurations		↕			↕		↕	↕		↕	↕	↕
Traffic Vol, veh/h	18	1	22	3	1	0	30	40	0	3	57	33
Future Vol, veh/h	18	1	22	3	1	0	30	40	0	3	57	33
Peak Hour Factor	0.92	0.92	0.92	0.92	0.92	0.92	0.92	0.92	0.92	0.92	0.92	0.92
Heavy Vehicles, %	6	100	9	67	2	2	53	20	2	2	12	3
Mvmt Flow	20	1	24	3	1	0	33	43	0	3	62	36
Number of Lanes	0	1	0	0	1	0	1	1	0	1	1	1

Approach	EB	WB	NB	SB
Opposing Approach	WB	EB	SB	NB
Opposing Lanes	1	1	3	2
Conflicting Approach Left	SB	NB	EB	WB
Conflicting Lanes Left	3	2	1	1
Conflicting Approach Right	NB	SB	WB	EB
Conflicting Lanes Right	2	3	1	1
HCM Control Delay	7.9	9.3	8.7	7.7
HCM LOS	A	A	A	A

Lane	NBLn1	NBLn2	EBLn1	WBLn1	SBLn1	SBLn2	SBLn3
Vol Left, %	100%	0%	44%	75%	100%	0%	0%
Vol Thru, %	0%	100%	2%	25%	0%	100%	0%
Vol Right, %	0%	0%	54%	0%	0%	0%	100%
Sign Control	Stop	Stop	Stop	Stop	Stop	Stop	Stop
Traffic Vol by Lane	30	40	41	4	3	57	33
LT Vol	30	0	18	3	3	0	0
Through Vol	0	40	1	1	0	57	0
RT Vol	0	0	22	0	0	0	33
Lane Flow Rate	33	43	45	4	3	62	36
Geometry Grp	8	8	7	7	7	7	7
Degree of Util (X)	0.057	0.063	0.061	0.008	0.005	0.083	0.04
Departure Headway (Hd)	6.24	5.177	4.89	6.497	5.16	4.83	3.976
Convergence, Y/N	Yes	Yes	Yes	Yes	Yes	Yes	Yes
Cap	577	695	736	554	687	734	888
Service Time	3.945	2.882	2.595	4.204	2.943	2.612	1.757
HCM Lane V/C Ratio	0.057	0.062	0.061	0.007	0.004	0.084	0.041
HCM Control Delay	9.3	8.2	7.9	9.3	8	8.1	6.9
HCM Lane LOS	A	A	A	A	A	A	A
HCM 95th-tile Q	0.2	0.2	0.2	0	0	0.3	0.1

Intersection	
Intersection Delay, s/veh	9.1
Intersection LOS	A

Movement	EBL	EBT	EBR	WBL	WBT	WBR	NBL	NBT	NBR	SBL	SBT	SBR
Lane Configurations		↕			↕		↕	↕		↕	↕	↕
Traffic Vol, veh/h	99	2	30	0	3	1	26	99	0	3	24	17
Future Vol, veh/h	99	2	30	0	3	1	26	99	0	3	24	17
Peak Hour Factor	0.80	0.80	0.80	0.80	0.80	0.80	0.80	0.80	0.80	0.80	0.80	0.80
Heavy Vehicles, %	2	50	40	2	33	2	23	2	2	2	2	12
Mvmt Flow	124	3	38	0	4	1	33	124	0	4	30	21
Number of Lanes	0	1	0	0	1	0	1	1	0	1	1	1

Approach	EB	WB	NB	SB
Opposing Approach	WB	EB	SB	NB
Opposing Lanes	1	1	3	2
Conflicting Approach Left	SB	NB	EB	WB
Conflicting Lanes Left	3	2	1	1
Conflicting Approach Right	NB	SB	WB	EB
Conflicting Lanes Right	2	3	1	1
HCM Control Delay	9.7	8.4	9	7.9
HCM LOS	A	A	A	A

Lane	NBLn1	NBLn2	EBLn1	WBLn1	SBLn1	SBLn2	SBLn3
Vol Left, %	100%	0%	76%	0%	100%	0%	0%
Vol Thru, %	0%	100%	2%	75%	0%	100%	0%
Vol Right, %	0%	0%	23%	25%	0%	0%	100%
Sign Control	Stop	Stop	Stop	Stop	Stop	Stop	Stop
Traffic Vol by Lane	26	99	131	4	3	24	17
LT Vol	26	0	99	0	3	0	0
Through Vol	0	99	2	3	0	24	0
RT Vol	0	0	30	1	0	0	17
Lane Flow Rate	32	124	164	5	4	30	21
Geometry Grp	8	8	7	7	7	7	7
Degree of Util (X)	0.055	0.178	0.24	0.008	0.006	0.043	0.027
Departure Headway (Hd)	6.037	5.174	5.284	5.592	5.67	5.166	4.633
Convergence, Y/N	Yes	Yes	Yes	Yes	Yes	Yes	Yes
Cap	594	694	681	640	632	694	773
Service Time	3.762	2.899	3.009	3.324	3.397	2.893	2.36
HCM Lane V/C Ratio	0.054	0.179	0.241	0.008	0.006	0.043	0.027
HCM Control Delay	9.1	9	9.7	8.4	8.4	8.1	7.5
HCM Lane LOS	A	A	A	A	A	A	A
HCM 95th-tile Q	0.2	0.6	0.9	0	0	0.1	0.1

Intersection	
Intersection Delay, s/veh	7.9
Intersection LOS	A

Movement	EBL	EBT	EBR	WBL	WBT	WBR	NBL	NBT	NBR	SBL	SBT	SBR
Lane Configurations		↕			↕		↕	↕		↕	↕	↕
Traffic Vol, veh/h	18	1	8	3	1	0	9	39	0	3	55	33
Future Vol, veh/h	18	1	8	3	1	0	9	39	0	3	55	33
Peak Hour Factor	0.92	0.92	0.92	0.92	0.92	0.92	0.92	0.92	0.92	0.92	0.92	0.92
Heavy Vehicles, %	6	100	2	67	2	2	11	21	2	2	13	3
Mvmt Flow	20	1	9	3	1	0	10	42	0	3	60	36
Number of Lanes	0	1	0	0	1	0	1	1	0	1	1	1

Approach	EB	WB	NB	SB
Opposing Approach	WB	EB	SB	NB
Opposing Lanes	1	1	3	2
Conflicting Approach Left	SB	NB	EB	WB
Conflicting Lanes Left	3	2	1	1
Conflicting Approach Right	NB	SB	WB	EB
Conflicting Lanes Right	2	3	1	1
HCM Control Delay	8	9.2	8.2	7.6
HCM LOS	A	A	A	A

Lane	NBLn1	NBLn2	EBLn1	WBLn1	SBLn1	SBLn2	SBLn3
Vol Left, %	100%	0%	67%	75%	100%	0%	0%
Vol Thru, %	0%	100%	4%	25%	0%	100%	0%
Vol Right, %	0%	0%	30%	0%	0%	0%	100%
Sign Control	Stop	Stop	Stop	Stop	Stop	Stop	Stop
Traffic Vol by Lane	9	39	27	4	3	55	33
LT Vol	9	0	18	3	3	0	0
Through Vol	0	39	1	1	0	55	0
RT Vol	0	0	8	0	0	0	33
Lane Flow Rate	10	42	29	4	3	60	36
Geometry Grp	8	8	7	7	7	7	7
Degree of Util (X)	0.015	0.06	0.042	0.008	0.005	0.08	0.039
Departure Headway (Hd)	5.383	5.053	5.092	6.402	5.12	4.807	3.936
Convergence, Y/N	Yes	Yes	Yes	Yes	Yes	Yes	Yes
Cap	657	699	708	562	696	741	902
Service Time	3.181	2.85	2.792	4.103	2.876	2.563	1.692
HCM Lane V/C Ratio	0.015	0.06	0.041	0.007	0.004	0.081	0.04
HCM Control Delay	8.3	8.2	8	9.2	7.9	8	6.9
HCM Lane LOS	A	A	A	A	A	A	A
HCM 95th-tile Q	0	0.2	0.1	0	0	0.3	0.1

Intersection	
Intersection Delay, s/veh	9
Intersection LOS	A

Movement	EBL	EBT	EBR	WBL	WBT	WBR	NBL	NBT	NBR	SBL	SBT	SBR
Lane Configurations		↕			↕		↕	↕		↕	↕	↕
Traffic Vol, veh/h	99	2	10	0	3	1	10	97	0	3	23	17
Future Vol, veh/h	99	2	10	0	3	1	10	97	0	3	23	17
Peak Hour Factor	0.80	0.80	0.80	0.80	0.80	0.80	0.80	0.80	0.80	0.80	0.80	0.80
Heavy Vehicles, %	2	50	2	2	33	2	10	2	2	2	2	12
Mvmt Flow	124	3	13	0	4	1	13	121	0	4	29	21
Number of Lanes	0	1	0	0	1	0	1	1	0	1	1	1

Approach	EB	WB	NB	SB
Opposing Approach	WB	EB	SB	NB
Opposing Lanes	1	1	3	2
Conflicting Approach Left	SB	NB	EB	WB
Conflicting Lanes Left	3	2	1	1
Conflicting Approach Right	NB	SB	WB	EB
Conflicting Lanes Right	2	3	1	1
HCM Control Delay	9.5	8.3	8.9	7.8
HCM LOS	A	A	A	A

Lane	NBLn1	NBLn2	EBLn1	WBLn1	SBLn1	SBLn2	SBLn3
Vol Left, %	100%	0%	89%	0%	100%	0%	0%
Vol Thru, %	0%	100%	2%	75%	0%	100%	0%
Vol Right, %	0%	0%	9%	25%	0%	0%	100%
Sign Control	Stop	Stop	Stop	Stop	Stop	Stop	Stop
Traffic Vol by Lane	10	97	111	4	3	23	17
LT Vol	10	0	99	0	3	0	0
Through Vol	0	97	2	3	0	23	0
RT Vol	0	0	10	1	0	0	17
Lane Flow Rate	12	121	139	5	4	29	21
Geometry Grp	8	8	7	7	7	7	7
Degree of Util (X)	0.02	0.172	0.207	0.008	0.006	0.041	0.027
Departure Headway (Hd)	5.742	5.102	5.383	5.496	5.575	5.072	4.539
Convergence, Y/N	Yes	Yes	Yes	Yes	Yes	Yes	Yes
Cap	625	704	669	652	643	707	790
Service Time	3.462	2.822	3.103	3.222	3.296	2.793	2.26
HCM Lane V/C Ratio	0.019	0.172	0.208	0.008	0.006	0.041	0.027
HCM Control Delay	8.6	8.9	9.5	8.3	8.3	8	7.4
HCM Lane LOS	A	A	A	A	A	A	A
HCM 95th-tile Q	0.1	0.6	0.8	0	0	0.1	0.1

Intersection	
Intersection Delay, s/veh	7.9
Intersection LOS	A

Movement	EBL	EBT	EBR	WBL	WBT	WBR	NBL	NBT	NBR	SBL	SBT	SBR
Lane Configurations		↕			↕		↕	↕		↕	↕	↕
Traffic Vol, veh/h	18	1	16	3	1	0	20	40	0	3	56	33
Future Vol, veh/h	18	1	16	3	1	0	20	40	0	3	56	33
Peak Hour Factor	0.92	0.92	0.92	0.92	0.92	0.92	0.92	0.92	0.92	0.92	0.92	0.92
Heavy Vehicles, %	6	100	6	67	2	2	35	20	2	2	13	3
Mvmt Flow	20	1	17	3	1	0	22	43	0	3	61	36
Number of Lanes	0	1	0	0	1	0	1	1	0	1	1	1

Approach	EB	WB	NB	SB
Opposing Approach	WB	EB	SB	NB
Opposing Lanes	1	1	3	2
Conflicting Approach Left	SB	NB	EB	WB
Conflicting Lanes Left	3	2	1	1
Conflicting Approach Right	NB	SB	WB	EB
Conflicting Lanes Right	2	3	1	1
HCM Control Delay	7.9	9.2	8.4	7.6
HCM LOS	A	A	A	A

Lane	NBLn1	NBLn2	EBLn1	WBLn1	SBLn1	SBLn2	SBLn3
Vol Left, %	100%	0%	51%	75%	100%	0%	0%
Vol Thru, %	0%	100%	3%	25%	0%	100%	0%
Vol Right, %	0%	0%	46%	0%	0%	0%	100%
Sign Control	Stop	Stop	Stop	Stop	Stop	Stop	Stop
Traffic Vol by Lane	20	40	35	4	3	56	33
LT Vol	20	0	18	3	3	0	0
Through Vol	0	40	1	1	0	56	0
RT Vol	0	0	16	0	0	0	33
Lane Flow Rate	22	43	38	4	3	61	36
Geometry Grp	8	8	7	7	7	7	7
Degree of Util (X)	0.036	0.062	0.052	0.008	0.005	0.082	0.039
Departure Headway (Hd)	5.913	5.159	4.943	6.45	5.142	4.829	3.958
Convergence, Y/N	Yes	Yes	Yes	Yes	Yes	Yes	Yes
Cap	609	698	728	558	691	736	895
Service Time	3.615	2.859	2.647	4.155	2.911	2.597	1.726
HCM Lane V/C Ratio	0.036	0.062	0.052	0.007	0.004	0.083	0.04
HCM Control Delay	8.8	8.2	7.9	9.2	7.9	8	6.9
HCM Lane LOS	A	A	A	A	A	A	A
HCM 95th-tile Q	0.1	0.2	0.2	0	0	0.3	0.1

Intersection	
Intersection Delay, s/veh	9.1
Intersection LOS	A

Movement	EBL	EBT	EBR	WBL	WBT	WBR	NBL	NBT	NBR	SBL	SBT	SBR
Lane Configurations		↕			↕		↕	↕		↕	↕	↕
Traffic Vol, veh/h	99	2	23	0	3	1	20	98	0	3	24	17
Future Vol, veh/h	99	2	23	0	3	1	20	98	0	3	24	17
Peak Hour Factor	0.80	0.80	0.80	0.80	0.80	0.80	0.80	0.80	0.80	0.80	0.80	0.80
Heavy Vehicles, %	2	50	35	2	33	2	20	2	2	2	2	12
Mvmt Flow	124	3	29	0	4	1	25	123	0	4	30	21
Number of Lanes	0	1	0	0	1	0	1	1	0	1	1	1

Approach	EB	WB	NB	SB
Opposing Approach	WB	EB	SB	NB
Opposing Lanes	1	1	3	2
Conflicting Approach Left	SB	NB	EB	WB
Conflicting Lanes Left	3	2	1	1
Conflicting Approach Right	NB	SB	WB	EB
Conflicting Lanes Right	2	3	1	1
HCM Control Delay	9.6	8.3	9	7.9
HCM LOS	A	A	A	A

Lane	NBLn1	NBLn2	EBLn1	WBLn1	SBLn1	SBLn2	SBLn3
Vol Left, %	100%	0%	80%	0%	100%	0%	0%
Vol Thru, %	0%	100%	2%	75%	0%	100%	0%
Vol Right, %	0%	0%	19%	25%	0%	0%	100%
Sign Control	Stop	Stop	Stop	Stop	Stop	Stop	Stop
Traffic Vol by Lane	20	98	124	4	3	24	17
LT Vol	20	0	99	0	3	0	0
Through Vol	0	98	2	3	0	24	0
RT Vol	0	0	23	1	0	0	17
Lane Flow Rate	25	122	155	5	4	30	21
Geometry Grp	8	8	7	7	7	7	7
Degree of Util (X)	0.041	0.175	0.229	0.008	0.006	0.043	0.027
Departure Headway (Hd)	5.961	5.15	5.313	5.558	5.636	5.132	4.599
Convergence, Y/N	Yes	Yes	Yes	Yes	Yes	Yes	Yes
Cap	602	697	677	645	636	698	779
Service Time	3.685	2.874	3.033	3.285	3.36	2.857	2.324
HCM Lane V/C Ratio	0.042	0.175	0.229	0.008	0.006	0.043	0.027
HCM Control Delay	8.9	9	9.6	8.3	8.4	8.1	7.5
HCM Lane LOS	A	A	A	A	A	A	A
HCM 95th-tile Q	0.1	0.6	0.9	0	0	0.1	0.1

Intersection	
Intersection Delay, s/veh	7.9
Intersection LOS	A

Movement	EBL	EBT	EBR	WBL	WBT	WBR	NBL	NBT	NBR	SBL	SBT	SBR
Lane Configurations		↕			↕		↕	↕		↕	↕	↕
Traffic Vol, veh/h	18	1	9	3	1	0	14	39	0	3	55	33
Future Vol, veh/h	18	1	9	3	1	0	14	39	0	3	55	33
Peak Hour Factor	0.92	0.92	0.92	0.92	0.92	0.92	0.92	0.92	0.92	0.92	0.92	0.92
Heavy Vehicles, %	6	100	11	67	2	2	43	21	2	2	13	3
Mvmt Flow	20	1	10	3	1	0	15	42	0	3	60	36
Number of Lanes	0	1	0	0	1	0	1	1	0	1	1	1

Approach	EB	WB	NB	SB
Opposing Approach	WB	EB	SB	NB
Opposing Lanes	1	1	3	2
Conflicting Approach Left	SB	NB	EB	WB
Conflicting Lanes Left	3	2	1	1
Conflicting Approach Right	NB	SB	WB	EB
Conflicting Lanes Right	2	3	1	1
HCM Control Delay	8	9.2	8.4	7.6
HCM LOS	A	A	A	A

Lane	NBLn1	NBLn2	EBLn1	WBLn1	SBLn1	SBLn2	SBLn3
Vol Left, %	100%	0%	64%	75%	100%	0%	0%
Vol Thru, %	0%	100%	4%	25%	0%	100%	0%
Vol Right, %	0%	0%	32%	0%	0%	0%	100%
Sign Control	Stop	Stop	Stop	Stop	Stop	Stop	Stop
Traffic Vol by Lane	14	39	28	4	3	55	33
LT Vol	14	0	18	3	3	0	0
Through Vol	0	39	1	1	0	55	0
RT Vol	0	0	9	0	0	0	33
Lane Flow Rate	15	42	30	4	3	60	36
Geometry Grp	8	8	7	7	7	7	7
Degree of Util (X)	0.025	0.06	0.043	0.008	0.005	0.08	0.039
Departure Headway (Hd)	5.93	5.055	5.08	6.421	5.125	4.811	3.941
Convergence, Y/N	Yes	Yes	Yes	Yes	Yes	Yes	Yes
Cap	597	699	709	561	694	740	901
Service Time	3.728	2.853	2.78	4.121	2.884	2.571	1.7
HCM Lane V/C Ratio	0.025	0.06	0.042	0.007	0.004	0.081	0.04
HCM Control Delay	8.9	8.2	8	9.2	7.9	8	6.9
HCM Lane LOS	A	A	A	A	A	A	A
HCM 95th-tile Q	0.1	0.2	0.1	0	0	0.3	0.1

Intersection	
Intersection Delay, s/veh	9
Intersection LOS	A

Movement	EBL	EBT	EBR	WBL	WBT	WBR	NBL	NBT	NBR	SBL	SBT	SBR
Lane Configurations		↕			↕		↕	↕		↕	↕	↕
Traffic Vol, veh/h	99	2	14	0	3	1	12	97	0	3	23	17
Future Vol, veh/h	99	2	14	0	3	1	12	97	0	3	23	17
Peak Hour Factor	0.80	0.80	0.80	0.80	0.80	0.80	0.80	0.80	0.80	0.80	0.80	0.80
Heavy Vehicles, %	2	50	29	2	33	2	25	2	2	2	2	12
Mvmt Flow	124	3	18	0	4	1	15	121	0	4	29	21
Number of Lanes	0	1	0	0	1	0	1	1	0	1	1	1

Approach	EB	WB	NB	SB
Opposing Approach	WB	EB	SB	NB
Opposing Lanes	1	1	3	2
Conflicting Approach Left	SB	NB	EB	WB
Conflicting Lanes Left	3	2	1	1
Conflicting Approach Right	NB	SB	WB	EB
Conflicting Lanes Right	2	3	1	1
HCM Control Delay	9.5	8.3	8.9	7.8
HCM LOS	A	A	A	A

Lane	NBLn1	NBLn2	EBLn1	WBLn1	SBLn1	SBLn2	SBLn3
Vol Left, %	100%	0%	86%	0%	100%	0%	0%
Vol Thru, %	0%	100%	2%	75%	0%	100%	0%
Vol Right, %	0%	0%	12%	25%	0%	0%	100%
Sign Control	Stop	Stop	Stop	Stop	Stop	Stop	Stop
Traffic Vol by Lane	12	97	115	4	3	23	17
LT Vol	12	0	99	0	3	0	0
Through Vol	0	97	2	3	0	23	0
RT Vol	0	0	14	1	0	0	17
Lane Flow Rate	15	121	144	5	4	29	21
Geometry Grp	8	8	7	7	7	7	7
Degree of Util (X)	0.025	0.172	0.214	0.008	0.006	0.041	0.027
Departure Headway (Hd)	6.012	5.116	5.353	5.51	5.592	5.089	4.556
Convergence, Y/N	Yes	Yes	Yes	Yes	Yes	Yes	Yes
Cap	597	702	673	650	641	705	787
Service Time	3.734	2.838	3.074	3.236	3.314	2.811	2.278
HCM Lane V/C Ratio	0.025	0.172	0.214	0.008	0.006	0.041	0.027
HCM Control Delay	8.9	8.9	9.5	8.3	8.3	8	7.4
HCM Lane LOS	A	A	A	A	A	A	A
HCM 95th-tile Q	0.1	0.6	0.8	0	0	0.1	0.1